

MICROWAVE ENERGY FOR FUEL CONVERSION PROCESSES

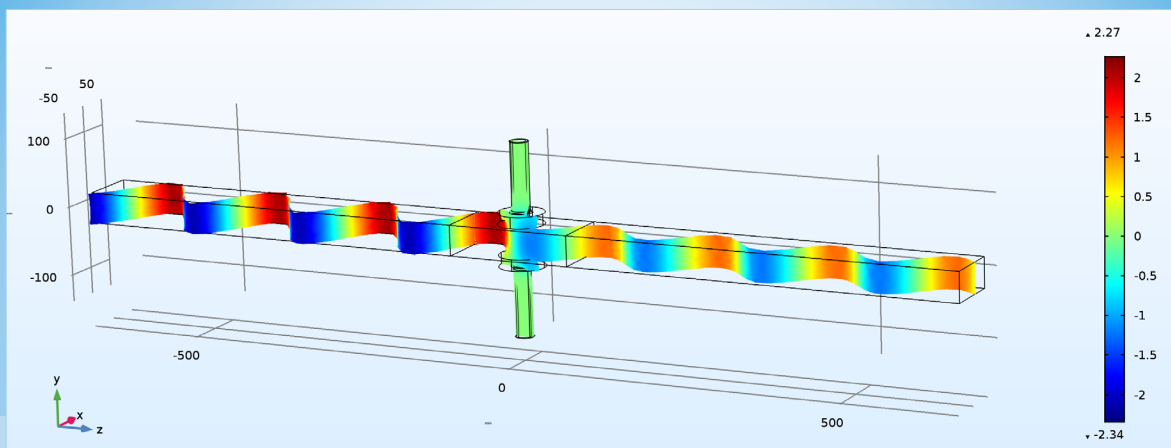

BACKGROUND

The U.S. Department of Energy is developing microwave-assisted technologies for chemical conversion processes. The rapid nature of the selective heating associated with microwave (MW) power can overcome significant lag times in the medium to be heated compared to thermal methods. Beyond selective heating, a non-thermal MW effect has been proposed as a possible explanation for enhanced conversion and selectivity, which can exceed equilibrium values. However, the detailed mechanisms of the MW-catalyst interactions are not completely known.

NETL is developing in-house expertise in this area. It is expected that future efforts using optical diagnostics, modeling, and simulation techniques will allow DOE researchers to identify the critical factors and kinetic routes responsible for the observed catalytic effects. Such efforts will allow for the optimization of microwave systems so that they may be incorporated into a broad range of chemical conversion technologies. Furthermore, new catalysts that produce enhanced interactions with the electromagnetic fields will be designed and synthesized to promote yet undiscovered effects in this emerging area of charged particle-driven chemistry.

NETL

NATIONAL ENERGY TECHNOLOGY LABORATORY

BENEFITS

High frequency MW fields can selectively stimulate active metal sites on catalysts (through dielectric heating and bond relaxation) without increasing the local gas temperature. Fundamental understanding of the science behind these phenomena is needed for an optimal design of an efficient microwave system for fossil energy applications.

The application of radio frequency/microwave fields to chemical reactions may transform the way chemical processes are performed. Microwave effects can result in greatly enhanced reactions rates, generation of completely different products, and changes in product selectivity or position of chemical equilibria - in many cases requiring far less energy.

These extremely useful properties need to be fully understood with new microwave-specific catalysts and catalytic processes. Further, because many energy-intensive chemical processes can produce negative environmental impacts, more sustainable chemical technologies are needed. This need can be met, at least in part, through a directed effort to exploit unique properties of microwave-driven catalysis, with the goal of providing enabling technology for energy-intensive reactions.

FACILITIES

- **Two gas-solid microwave plasma reactor systems:** a pulsing single-mode microwave cavity from Sairem (model: GMP20K) with fixed frequency (2.45 GHz) 2KW magnetron (Fig. 1) and a continuous variable frequency (2-8 GHz), 0.5KW microwave reactor from Lambda Technologies, Inc. (Fig. 2).
- **Two microwave vector network analyzers (VNAs):** analyzers with frequency ranges of 300 kHz to 13.5 GHz and 10 MHz to 43.5 GHz to study the electric and magnetic properties of plasma catalysts. The VNAs can be also be coupled to a high-temperature coaxial airline sample holder cell

(up to 800 °C), which is being developed at NETL to provide information about the electromagnetic properties of catalysts as a function of temperature. This system is being developed to determine microwave plasma frequency under controlled in situ reaction conditions of inert or reactive catalyst and gas environment and is believed to be the first of its kind.

- **Vibrating Sample Magnetometer (VSM) unit:** unit used to study the magnetometry and field-dependent electrical transport properties of materials from cryogenic temperatures to elevated temperatures up to 1000 °C and with magnetic field up to 2 tesla (T).

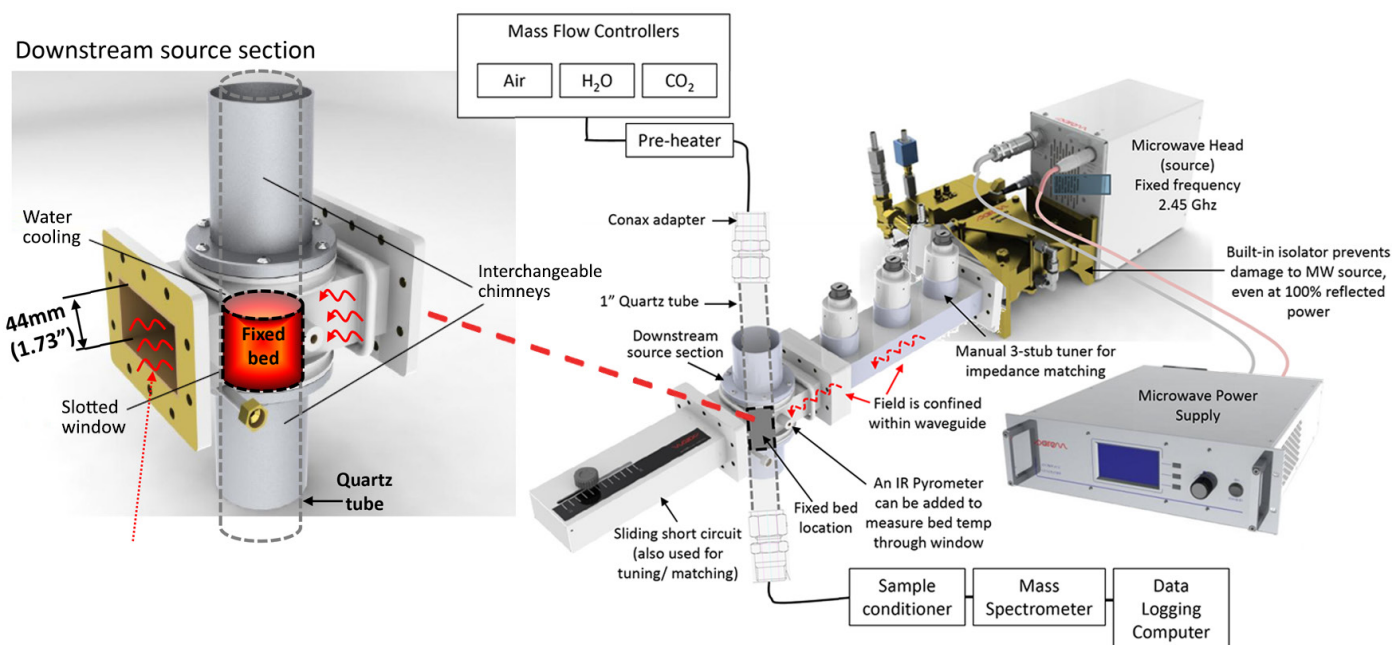

Figure 1

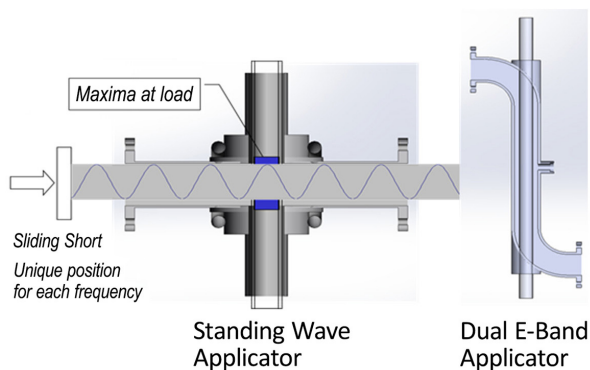

Figure 2

MICROWAVE ENERGY FOR FUEL CONVERSION PROCESSES

SIGNIFICANT RESULTS AND MAJOR ACCOMPLISHMENTS

- Applying microwaves to several conversion reactions has been investigated at the proof-of-concept level at NETL. Those proof-of-concept runs proved that conversion and product selectivity can be enhanced by applying radio frequency/microwave fields near the reaction zone.
- A recent paper investigated microwave-assisted pyrolysis, which is a thermochemical pre-treatment step in any coal conversion process that devolatilizes coal and reduces its sulfur and heavy tar content. The study looked at the pyrolysis of Mississippi coal and compared it to conventional pyrolysis. Results showed that microwaved pyrolysis of the coal produced higher gas yields at low temperatures, with less tars.
- Coal Gasification: MW significantly enhanced the formation of hydrogen (H_2) at low gasification temperatures (600 °C) and ambient pressure compared to conventional operation (Fig. 3).

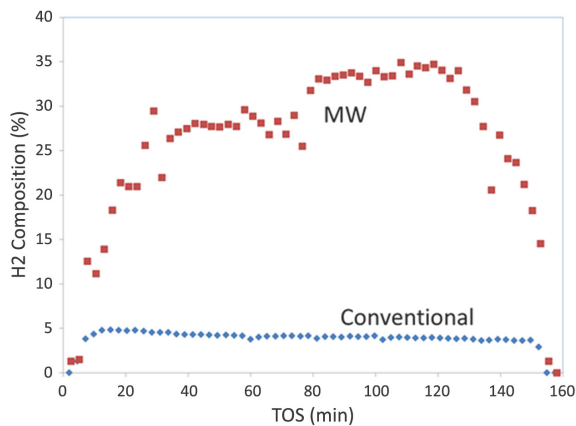

Figure 3: Coal steam gasification.

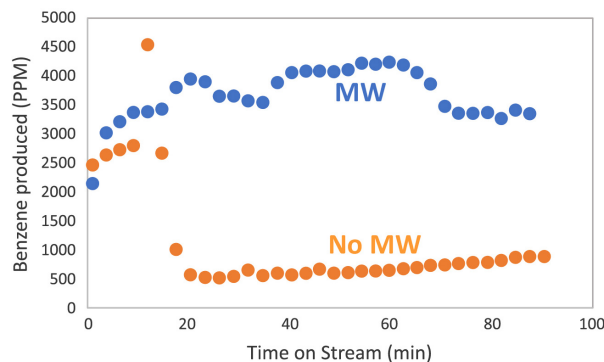

Figure 5: Microwave-assisted conversion of low rank coals in presence of natural gas into value-added chemicals.

- For methane dehydroaromatization reaction, benzene yield increased significantly in the presence of microwave field (Fig. 4).
- Coal pyrolysis in the presence of H_2 and methane (500 °C): The product distribution tends to shift to lower molecular weight tars under MW heating (Fig. 5).
- For an ARPA-E project, by microwave irradiation NETL showed that significantly higher ammonia yields can be achieved at low temperatures (300 °C) and ambient pressure using metallic supported catalyst systems.
- A variable frequency microwave reactor (VFMWR) has been developed. To the best of our knowledge, this VFMWR capability is a one-of-a-kind system and does not exist in any other research laboratory in the world.
- NETL researchers are also looking toward MW-activated materials development, along with further microwave research that will advance electromagnetic field characterization by understanding how geometry and surfaces interact with the microwaves and micro-discharges in the spaces between particles.

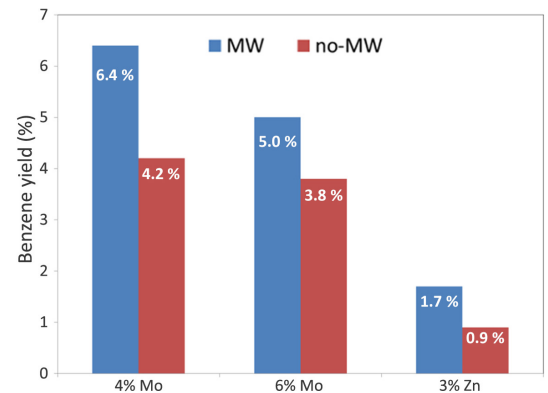

Figure 4: Methane to benzene reaction. Microwaves significantly improved the catalyst performance even though the catalyst used was not designed for MW conditions.



Contacts

Dushyant Shekhawat
Supervisor, Reaction Engineering Team
Energy Conversion Engineering
dushyant.shekhawat@netl.doe.gov

David Berry
Associate Director
Energy Conversion Engineering Directorate
david.berry@netl.doe.gov