

# SOLID OXIDE FUEL CELLS

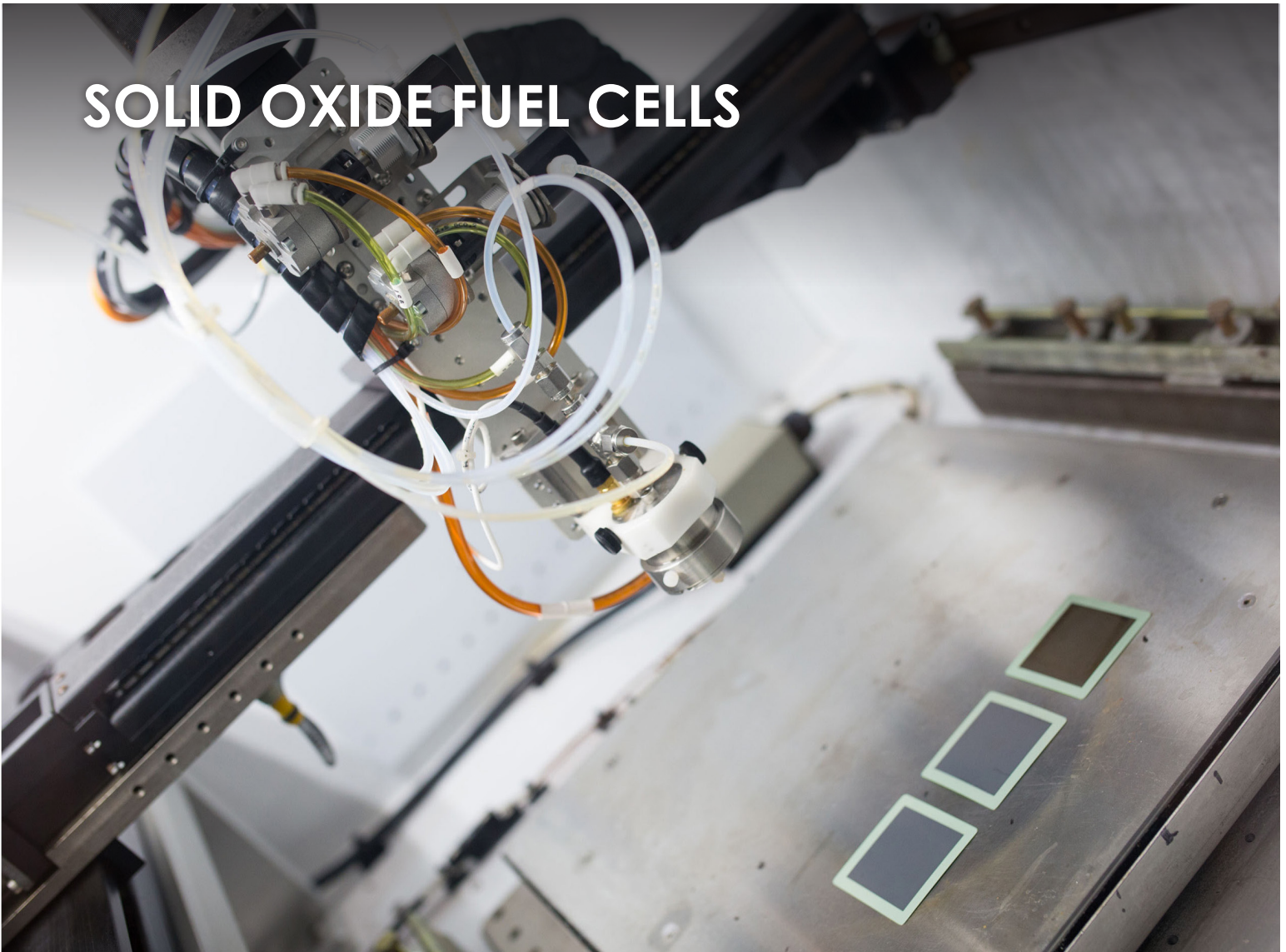

# NETL

**NATIONAL ENERGY TECHNOLOGY LABORATORY**

The National Energy Technology Laboratory (NETL) Solid Oxide Fuel Cell (SOFC) Team performs fundamental SOFC technology evaluation, enhances existing SOFC technology and develops advanced SOFC concepts in support of the U.S. Department of Energy SOFC Program. Research efforts are designed to meet critical technology development needs that can be uniquely addressed and are broadly focused on investigation of cell and stack degradation, electrode engineering, and system analysis. The research approach is targeted to address SOFC program technology development goals, especially regarding reducing stack costs, increasing cell efficiency and increasing cell reliability and robustness. The goal of these research and development efforts is to transfer technology that facilitates commercial acceptance of SOFC technology. This is done through close collaboration with SOFC commercial developers, national laboratories and several academic institutions. The research portfolio is broken into three efforts, which are described in the subsequent sections.

## ADVANCED FUEL CELL RESEARCH AT NETL SYSTEMS ENGINEERING AND ANALYSIS

The Systems Engineering and Analysis directorate within the Research and Innovation Center at NETL provides techno-economic analyses of critical baseline and future commercial plant configurations. Previously completed techno-economic analyses of SOFC plants have shown that the reduction of cell and stack degradation and an increase

in cell performance is vital toward the commercialization of a cost-competitive SOFC technology. Such analyses provide crucial information to guide research and development, ensuring that effort is placed where it will have a significant impact on the technology as well as to ensure that program goals and objectives are relevant and achievable.

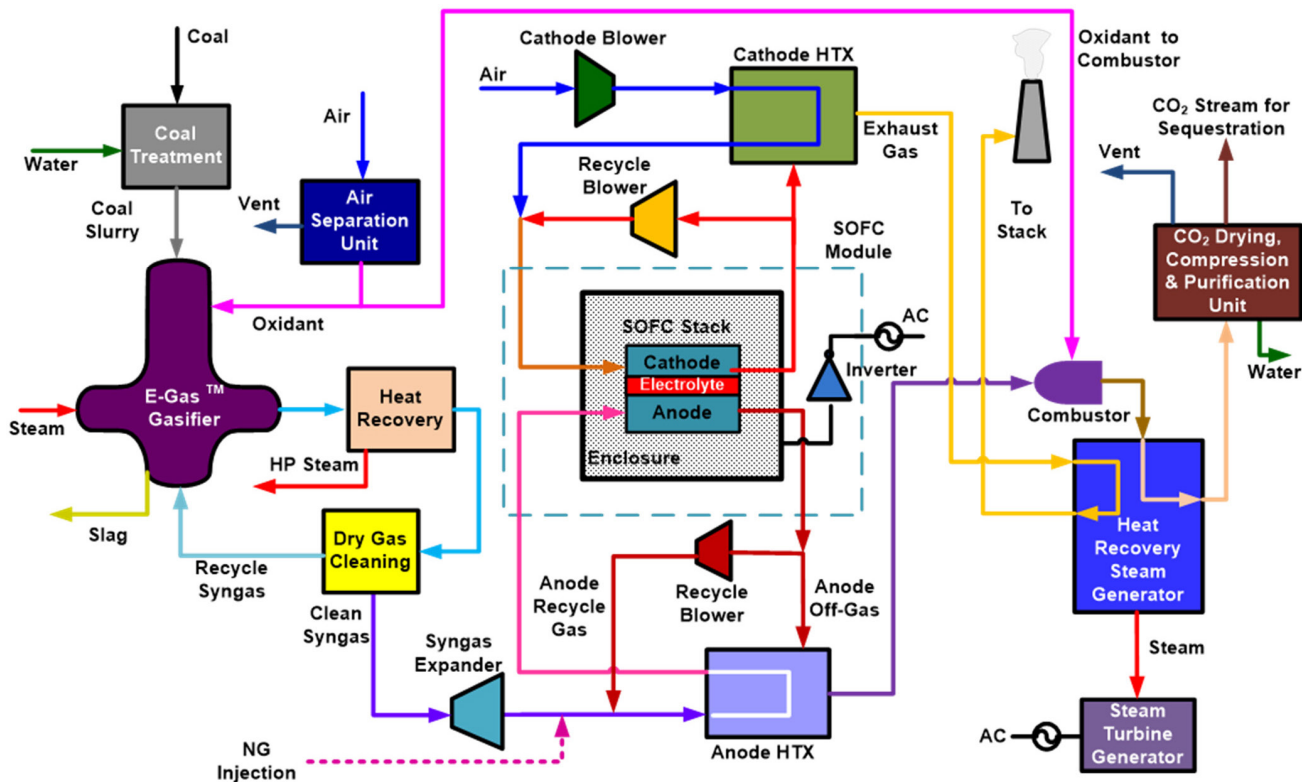

Fig. 1: Block flow diagram of an integrated gasification fuel cell power plant. Analysis of various configurations informs developers of an optimum arrangement to minimize the cost-of-electricity produced by the plant.

## CELL AND STACK DEGRADATION

Based on the results of systems analysis, the cell and stack degradation effort focuses on the development of characterization tools and predictive models that are critical to compile a complete knowledge of prominent degradation modes in SOFC anode/electrolyte/cathode structures. This effort builds upon knowledge gained previously to inform a comprehensive, predictive model to be distributed for public consumption. Through the development of the predictive model, several individual toolsets are being made available to commercial developers that will aid in the advancement of their technology. Advanced electrode reconstruction techniques that pinpoint changes in the electrode microstructure at high resolution are being developed and

can be used by commercial developers to evaluate their own technologies in detail. Advanced fiber optic sensors are under development that can provide distributed, in-situ temperature and gas composition information as the cell operates and with minimal invasiveness. An advanced electrochemical impedance spectroscopy analysis technique is being developed to help understand when and where degradation modes are occurring. These and several other techniques are being combined to evaluate a wide range of operating conditions relevant to commercial SOFC operation. This evaluation will be completed for both hydrogen and syngas fueled conditions in the predictive modeling toolset.

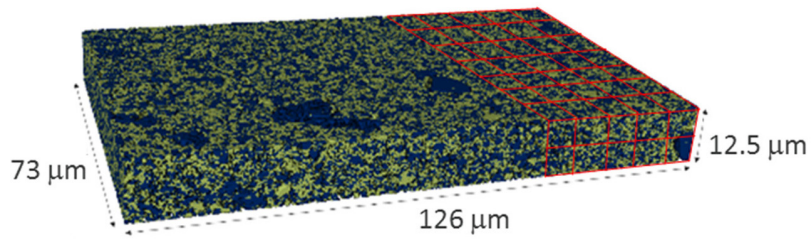

Fig. 2: Depiction of a high-resolution cathode reconstruction completed with plasma-focused ion beam technology at Carnegie Mellon University. This is currently the world's largest reconstruction volume and is being used to evaluate heterogeneities in the microstructure and how they affect the electrode's performance.

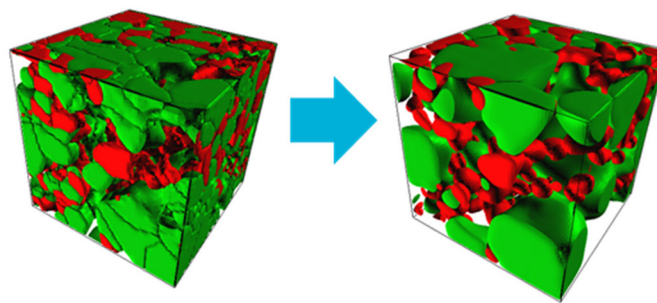

Fig. 3: Depiction of particle coarsening of a sub-volume of an SOFC cathode structure. Particle coarsening occurs over long durations and is one known mode of performance degradation as the coarsening results in active triple-phase boundary loss.

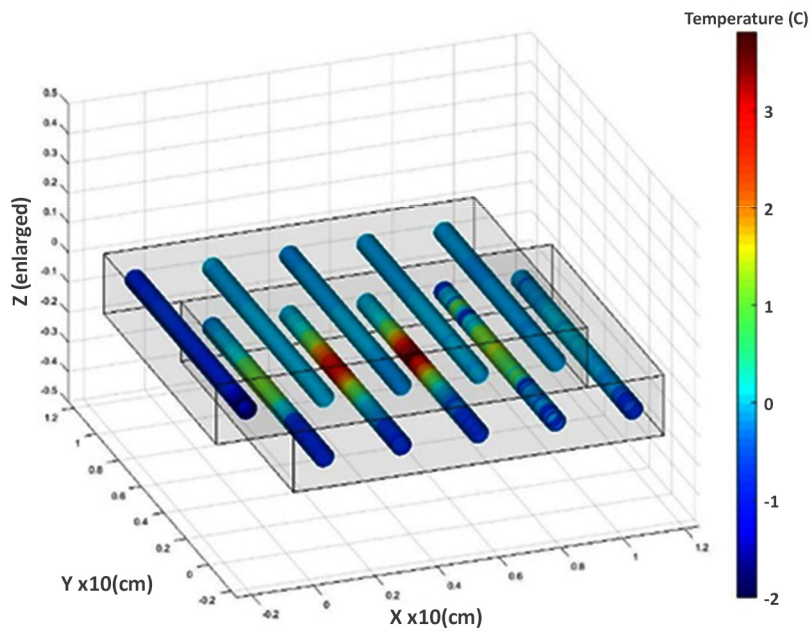

Fig. 4: Distributed temperature change on the anode (bottom five cylinders) and the cathode (top five) of an SOFC at 750 °C after 90 seconds of load (2 A) being drawn from a 16 cm<sup>2</sup> (4x4 cm) cell.



## ELECTRODE STRUCTURE AND MATERIALS ENGINEERING

Building upon the identification of degradation modes from the predictive model, electrode engineering methods are being developed to mitigate performance degradation, thereby reducing costs and improving the life of commercial SOFC products. NETL is working directly with commercial developers to improve their state-of-the-art technology performance and degradation rates. With NETL's patented process, a commercial cell is analyzed via detailed characterization techniques and a novel formulation of nano-catalyst is applied through a sonic spray coating method. NETL has shown success on several commercially-

developed cells and is currently investigating alternate uses for the technology such as reduced-temperature operation catalysts, materials to promote reversible SOFC operation and materials to alleviate stresses caused by redox cycling in nickel-based anodes. Successful technologies are actively transferred to industry.

These research efforts will improve overall electrode performance, resulting in increased cell efficiency and, ultimately, a lower system cost and extended lifetime, which are touchstones of SOFC commercialization.

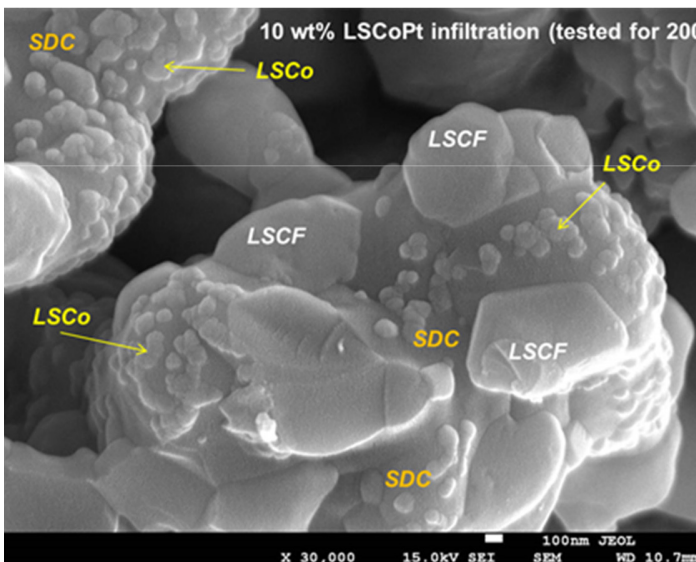

Fig. 5: Scanning electrode micrograph of LSCo-Pt nano-catalyst deposited on an LSCF-SDC based cathode material. The catalyst preferentially adheres to the electrolyte material in the cathode active region.

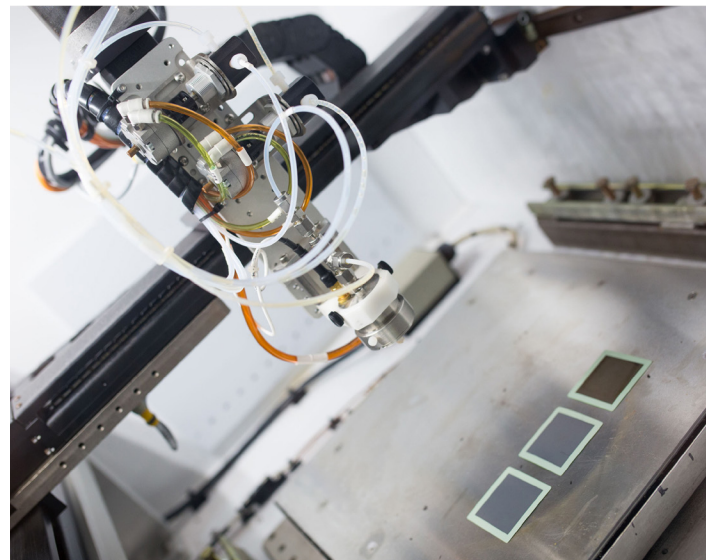

Fig. 6: Secretary of Energy, Rick Perry preparing to insert a commercial fuel cell (Atrex Energy) into NETL's sonic spray coat device for catalyst infiltration.

### Research Partners

Leidos Research Support Team (LRST)  
Atrex Energy  
Carnegie Mellon University  
Clemson University  
Pacific Northwest National Laboratory  
The Pennsylvania State University  
University of Wisconsin-Madison  
Wake Forest University  
West Virginia University

### Contacts

**Gregory A. Hackett**  
Technical Portfolio Lead, Solid Oxide Fuel Cells  
Energy Process Analysis Team  
Gregory.Hackett@netl.doe.gov

**Travis Shultz**  
Supervisor, Energy Process Analysis Team  
Systems Engineering and Analysis Directorate  
Travis.Shultz@netl.doe.gov