

SUPERCRITICAL CARBON DIOXIDE TECHNOLOGY



STEP
DEMO
www.stepdemo.us

Program 144, November 2024

NE NATIONAL ENERGY **TL** TECHNOLOGY LABORATORY

PROGRAM OVERVIEW

The Supercritical Carbon Dioxide Technology Program is focused on developing technologies for the implementation of highly efficient power cycles utilizing supercritical carbon dioxide (CO₂) as the working fluid. Supercritical CO₂-based power cycles have shown the potential for increased heat-to-electricity conversion efficiencies, high power density, and simplicity of operation compared to existing steam based power cycles. The supercritical CO₂ power cycle uses small turbomachinery, is fuel- and/or heat-source neutral, and is efficient. These factors make the cycle appealing to a wide range of applications and stakeholders. In addition to solar, nuclear, fossil, and geothermal heat sources, the supercritical CO₂ power cycle has applications for shipboard use in propulsion, power, and waste heat recovery. This broad range of applications makes the market-based development and deployment of the supercritical CO₂ power cycle highly attractive.

Figure 1 (Cover Image). Supercritical Transformation Electric Power (STEP) 10 MWe Pilot Plant Test Facility (DE-FE0028979) high bay during installation of turbine skid (left), high temperature recuperator (center), and main compressor/inventory system (right).



The Supercritical Carbon Dioxide Technology R&D program consists of developing turbomachinery and recuperators for indirect- and direct-fired cycles, oxy-fuel combustion for direct-fired cycles, and system integration and optimization of the supercritical CO₂ power cycle. The program aims to demonstrate improved power generation efficiency and progress toward lower cost of electricity using supercritical CO₂ power cycles. Advancements in supercritical CO₂ technologies can lead to significant progress in meeting national climate and energy goals, including decreased greenhouse gas emissions, promoting domestic manufacturing and technology job creation, facilitating industrial competitiveness, maintaining U.S. technology leadership, and providing the nation with cleaner and more affordable electric power.

SUPERCRITICAL CARBON DIOXIDE POWER CYCLE CONCEPTS

Supercritical CO₂-based power cycles can be implemented with indirectly and directly heated applications. The indirectly heated power cycle is a closed cycle applicable to externally supplied heat sources such as nuclear, solar energy storage, and carbon controlled combustion. There is essentially no loss or addition of CO₂ during operation after the system is initially charged. A heat source is used to indirectly heat the CO₂ working fluid through a heat exchanger, similar to current supercritical steam cycles. This cycle is a noncondensing closed loop Brayton cycle with heat addition and rejection on either side of the expander. Energy is extracted from the supercritical CO₂ as it is expanded in the turbine. The remaining heat is recovered from the post-expansion stream via recuperators and used to preheat the compressed CO₂ returning to the primary heat source.

In the recuperators, the CO₂ stream is cooled prior to compression. The compressed CO₂ stream is then preheated in the recuperators prior to returning to the heat source to complete the cycle. The recovery of waste heat in the recuperators limits the heat rejection from the cycle. Additionally, the ability to modulate the temperature of the supercritical CO₂ at the bottom of the cycle without condensing, provides potential for dry cooling with either low or no water consumption.

The directly fired supercritical carbon dioxide (sCO₂) power cycle is specifically designed to produce a low cost of electricity while capturing for storage nearly 100% of the CO₂. In the directly fired sCO₂ power cycles, the combustion of fuels, such as natural gas and oxygen, produces a stream of CO₂ and water that becomes the working fluid.

Designed for carbon capture, this cycle provides a competitive cost of electricity. If we add a biomass fuel gas, a carbon neutral cycle can be created, thus removing CO₂ from the atmosphere. The CO₂ working fluid drives the turbines and produces power before it is captured. The turbine for a direct-fired cycle operates at higher inlet

temperatures than that of the indirect-fired cycle. Unlike the indirect-fired cycle, the direct fired supercritical CO₂ power cycle can produce a high purity stream of CO₂ that is ready for use/reuse or storage, without expensive and energy intensive capture/separation technologies.

SUPERCRITICAL CARBON DIOXIDE TECHNOLOGY R&D PROGRAM

The Supercritical Carbon Dioxide Technology research and development (R&D) program is composed of technology focus areas dedicated to the development of the individual components of the power cycle along with systems analysis and modeling to address technical issues, reduce risks, and mature the technology. Furthermore, the R&D program is supportive of the Supercritical Transformational Electric Power (STEP) program that is focused on the development of a 10-MWe supercritical CO₂-based power cycle pilot facility.

PROGRAM GOALS

The Supercritical Carbon Dioxide Technology Program is working to develop highly efficient and lower cost indirectly and directly heated power cycles that surpass the performance of comparable cycles in a range of applications. These applications will be supported by developing the individual components and maturing the technology of the power cycles through technology readiness level paths to scaled-up testing. To accomplish the pilot-level demonstration, the R&D program is coordinated with the STEP program that aims to design, build, and operate a 10-MWe indirect-fired supercritical CO₂ power cycle pilot-scale facility and demonstrate the component performance, cycle operability, and progress toward a lower cost of electricity.

The objectives for the program are as follows:

- Develop and mature the supercritical CO₂ technology and allow the cost, efficiency, and lower water consumption benefits to be broadly realized in the energy sector.
- Mature the direct-fired cycle for cleaner and lower cost electric power with its inherent benefit of separating high-purity CO₂ at near-pipeline pressure and its clean water byproduct.

The Supercritical Carbon Dioxide Technology program supports R&D activities within four key technology areas: (1) Turbomachinery, (2) Recuperators, (3) Advanced Concepts for Direct-Fired Cycles, and (4) Systems Integration and Optimization. The R&D work is complementary to the STEP 10-MWe pilot facility program.

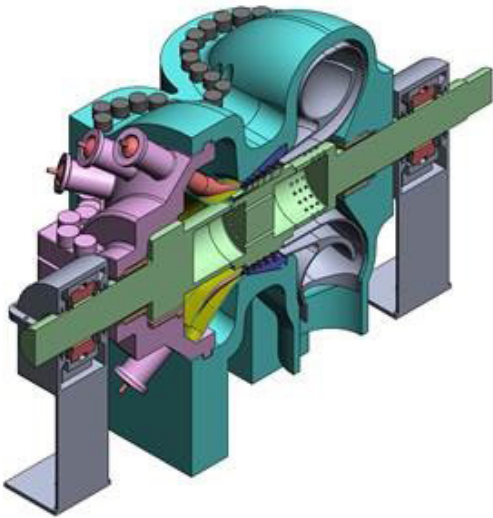

Figure 2. Preliminary design of a 300MWe Oxy-Fuel sCO₂ Turbine developed under DE-FE0031929

TECHNOLOGIES AND RESEARCH FOCUS AREAS

TURBOMACHINERY — Turbomachinery R&D focuses on advancing technologies and understanding of the supercritical CO₂ turbomachinery, including the interactions of the fluid with the turbomachinery, effects of high supercritical CO₂ densities on turbomachinery design, and operation at high temperatures and pressures of the supercritical CO₂ power cycles. R&D will consider all aspects of the turbomachinery, including the turbo-expander, compressors, pumps, airfoils, turbine coupling with the motor/generator, seals, casings, bearings, and shafts. The approach would cover a multiphase development to design and test supercritical CO₂ turbomachinery, followed by manufacture of commercial prototypes. Turbomachinery development will be supported by associated materials development efforts to test and identify materials compatible for use with supercritical CO₂ at the turbomachinery operating conditions.

RECUPERATORS — The supercritical CO₂-based power cycle utilizes high- and low-temperature recuperators to recover heat and increase cycle efficiency. The recuperator projects focus on the advancement of technologies, designs, and fabrication of recuperative heat exchangers. Work includes development and testing of innovative compact recuperator designs and identification of compatible materials to allow for highly efficient heat transfer under operation at high inlet temperatures and large pressure critical CO₂ power cycles. Multiple compact heat exchanger concepts will be identified, developed, and evaluated. Achieving recuperator cost and performance targets are vital to enabling commercial implementation of the supercritical CO₂ power cycle.

The supercritical CO₂ power cycle can be integrated with a multitude of heat sources in various configurations to support energy storage, industrial decarbonization through efficiency gains, and advanced fossil, nuclear and solar applications.

ADVANCED CONCEPTS FOR DIRECT-FIRED CYCLES —

The higher temperature and pressure conditions of more advanced direct-fired conversion systems have the potential for even higher cycle efficiencies, while producing CO₂ for either storage or reuse purposes. This work is intended to develop high-pressure and high-temperature oxy-fuel combustion systems with CO₂ as the diluent, to be used for directly-heated supercritical CO₂ power cycles. Work includes the integration of novel oxy-combustors with a direct-fired turbine.

SYSTEMS INTEGRATION AND OPTIMIZATION —

The supercritical CO₂ power cycle can be integrated with a multitude of heat sources in various configurations to support energy storage, industrial decarbonization through efficiency gains, advanced fossil, nuclear and solar applications. The key here is to conduct advanced systems and technical/economic analysis with optimization tools to achieve low cost and high performance systems. Analysis by NETL and other national laboratories has allowed direct and indirect systems to be optimized for large-scale power generation with the capture of carbon dioxide. Optimal integration and process operating conditions must be identified to achieve high efficiency and lower cost electricity generation. Systems integration and optimization work focuses on overall system analysis, modeling, and engineering to integrate and design the supercritical CO₂ power cycle for optimized performance, efficiency, cost, and operability.

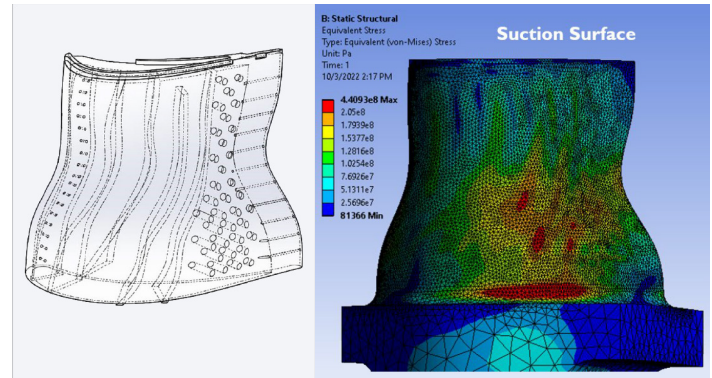

Figure 3. Preliminary cooled turbine blade design with internal cooling features (left) and corresponding stress contours (right) developed by Southwest Research Institute and Purdue University (DE-FE0031929) for a 300 MWe oxy-combustion turbine.

SUPERCRITICAL TRANSFORMATIONAL ELECTRIC POWER PROGRAM

The Supercritical Carbon Dioxide Technology Program R&D work described above is closely coordinated with the STEP program. The Office of Fossil Energy and Carbon Management leads the STEP program and is part of a Department of Energy-wide collaboration with the Offices of Nuclear Energy, and Energy Efficiency and Renewable Energy, which leverages the capabilities and interests of these organizations toward the development of supercritical CO₂ power cycles. The mission is to demonstrate a lower cost of electricity with supercritical CO₂ power cycles as applied to nuclear, concentrated solar, and fossil fuel heat sources. To support this mission, the main objective of the STEP program is to build and operate a 10-MWe supercritical CO₂ power cycle test facility for evaluating power cycle and component performance over a range of operating conditions at a relevant scale.



Figure 4. High Temperature Recuperator fabricated by Heatriac for the 10 MWe STEP Pilot Plant Test Facility

NETL is a U.S. Department of Energy (DOE) national laboratory dedicated to advancing the nation’s energy future by creating innovative solutions that strengthen the security, affordability and reliability of energy systems and natural resources. With laboratories and computational capabilities at research facilities in Albany, Oregon; Morgantown, West Virginia; and Pittsburgh, Pennsylvania, NETL addresses energy challenges through implementing DOE programs across the nation and advancing energy technologies related to fossil fuels. By fostering collaborations and conducting world-class research, NETL strives to strengthen national energy security through energy technology development.

Contacts

David Lyons
S&T Deputy Director for Carbon Management
 Science & Technology Strategy Planning and Programs
 K.Lyons@netl.doe.gov

Robert Schrecengost
Division Director
 Hydrogen with Carbon Management (FECM)
 Robert.Schrecengost@hq.doe.gov

John Crane
Technology Manager
 Advanced Turbines
 John.Crane@netl.doe.gov