

# UNIVERSITY TRAINING AND RESEARCH

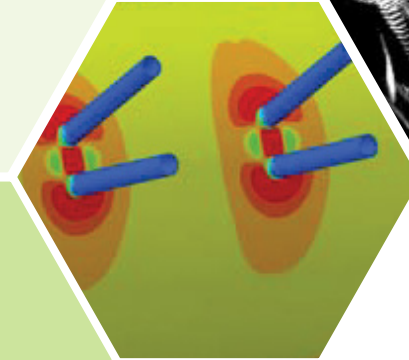

## PROJECT PORTFOLIO

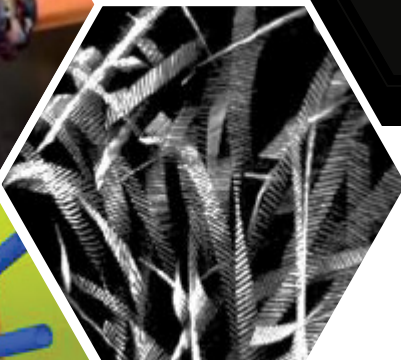
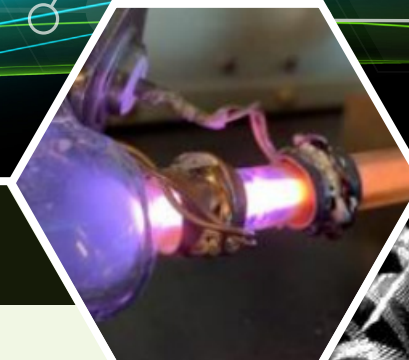

U.S. DEPARTMENT OF  
**ENERGY**



**NATIONAL  
ENERGY  
TECHNOLOGY  
LABORATORY**

## DISCLAIMER

This project was funded by the United States Department of Energy, National Energy Technology Laboratory, in part, through a site support contract. Neither the United States Government nor any agency thereof, nor any of their employees, nor the support contractor, nor any of their employees, makes any warranty, express or implied, or assumes any legal liability or responsibility for the accuracy, completeness, or usefulness of any information, apparatus, product, or process disclosed, or represents that its use would not infringe privately owned rights. Reference herein to any specific commercial product, process, or service by trade name, trademark, manufacturer, or otherwise does not necessarily constitute or imply its endorsement, recommendation, or favoring by the United States Government or any agency thereof. The views and opinions of authors expressed herein do not necessarily state or reflect those of the United States Government or any agency thereof.

# CONTENTS

<b>University Training and Research Program</b> .....	<b>6</b>
<b>Historically Black Colleges and Universities and Minority-Serving Institutions (HBCU-MSI)</b> .....	<b>11</b>
<b>ALGAE</b> .....	<b>13</b>
University of California - Riverside: An Experimental and Computational Approach to Investigating CO <sub>2</sub> Uptake of Cellulose-Producing Algae from Cellulosic Ethanol Product .....	13
<b>CARBON UTILIZATION</b> .....	<b>14</b>
Prairie View A&M University: Producing Algal Biomass from Wastewater as Cotton Plant Fertilizer to Reduce Carbon Footprint .....	14
<b>COAL ASH ANALYSIS</b> .....	<b>15</b>
Florida A&M University: Innovative Biomonitoring and Remediation of Heavy Metals Using Phytotechnologies at the Savannah River Site Coal Combustion Product Impoundment Sites.....	15
Kentucky State University: Mapping Soil Contamination from Coal Ash with Remote Sensing Analysis to Determine the Spatial Distribution and Impact on Soil Chemistry of Hyperaccumulator Plant Species .....	16
Texas State University: Infrastructure Assessment for Technology Innovation, Development and Training in Carbon Management.....	17
<b>ENERGY ASSET TRANSFORMATION</b> .....	<b>18</b>
University of Texas at El Paso: Microwave-Assisted Dehydrogenation of Fossil Fuels Using Iron-Based Alumina Nanocomposites .....	18
<b>EXISTING FLEET MODELING</b> .....	<b>19</b>
Cal State L.A. University Auxiliary Services, Inc.: R&D Scoping Study and Infrastructure Self-Assessment of Fossil Energy and Carbon Management Based Research Capabilities California State University .....	19
North Carolina Agricultural and Technical State University: Alloy for Enhancement of Operational Flexibility of Power Plants .....	20
<b>PROCESS SYSTEMS ENGINEERING</b> .....	<b>21</b>
Howard University: Multiphysics and Multiscale Simulation Methods for Electromagnetic Energy Assisted Fossil Fuel to Hydrogen Conversion.....	21
University of California - Riverside: Harnessing Plasma Experiments with Quantum Calculation for Low-Cost Hydrogen Production .....	22
University of Texas at El Paso: Capabilities Development at the University of Texas at El Paso for Hydrogen Generation Research and Education.....	23
University of Texas at El Paso: Overcoming Technical and Community Barriers to Adopting Gasification Technologies .....	24
University of Texas Rio Grande Valley: Assessment And Planning of Decarbonization Research and Training at University of Texas Rio Grande Valley .....	25

<b>SENSORS, CONTROLS, AND OTHER NOVEL CONCEPTS.....</b>	<b>26</b>
Morgan State University: Ceramic-Based Ultra-High Temperature Thermocouples in Harsh Environments .....	26
University of California - Riverside: Harnessing Quantum Information Science For Enhancing Sensors In Harsh Fossil Energy Environment .....	27
University of Texas at El Paso: Ultra-Low Disorder Graphene Quantum Dot-Based Spin Qubits for Cyber Secure Fossil Energy Infrastructure .....	28
University of Texas at El Paso: 5G Integrated Edge Computing Platform for Efficient Component Monitoring in Coal-Fired Power Plants.....	29
University of Texas at El Paso: 5G-Time Sensitive Networking Architecture Capable of Providing Real-Time Situational Awareness to Fossil-Energy (FE) Generation Systems .....	30
<b>SIMULATION-BASED ENGINEERING .....</b>	<b>31</b>
Florida International University: Development and Evaluation of a General Drag Model for Gas-Solid Flows Via Physics-Informed Deep Machine Learning .....	31
University of Texas at San Antonio: A General Drag Model for Assemblies of Non-Spherical Particles Created with Artificial Neural Networks .....	32
<b>WATER MANAGEMENT.....</b>	<b>33</b>
Florida A&M University: Fossil Energy in the Hydrogen Economy - A Carbon-Water-Energy Nexus Adaptive Evaluation Platform .....	33
<b>University Carbon Research (UCR).....</b>	<b>36</b>
<b>ADVANCED ENERGY MATERIALS.....</b>	<b>38</b>
Michigan Technological University: Hybrid Structured Nickel Superalloys to Address Price Volatility and Weld/Weld Repair Based Supply Chain Issues.....	38
Ohio State University: High-Speed and High-Quality Field Welding Repair Based on Advanced Non-Destructive Evaluation and Numerical Modeling .....	39
University of North Dakota: Electromagnetic Energy-Assisted Thermal Conversion of Fossil-Based Hydrocarbons to Low-Cost Hydrogen .....	40
West Virginia University Research Corporation: Conformal Coatings on Additive Manufactured Robust Alloys for Significant Mitigation of Oxidation, Erosion, and Corrosion.....	41
<b>COAL ASH ANALYSIS .....</b>	<b>42</b>
University of Nevada, Reno: Sustainable and Cost-Effective Phytoremediation Technologies in the Management of Contaminated Soils Adjacent to a Coal Combustion Product Impoundment .....	42
Virginia Polytechnic Institute and State University: A Data-Driven Multiscale Phytotechnology Framework for Identification and Remediation of Leached-Metals-Contaminated Soil Near Coal Ash Impoundments .....	43
West Virginia University: Integrated Life Cycle and Techno-Economic Assessments of Central Appalachian Legacy Mine Sites for Biomass Development and Waste Coal Utilization.....	44
<b>EXISTING FLEET MODELING .....</b>	<b>45</b>
University of North Dakota: Biogas Utilization in Refuse Power Plants (BURP2) .....	45
<b>HUMANITIES-DRIVEN SCIENCE, TECHNOLOGY, ENGINEERING AND MATHEMATICS (HDSTEM) .....</b>	<b>46</b>

Michigan Technical University: Aluminum Critical Mineral Production via Landfill Mining: Environmental, Community, and Technical Feasibility for Integrated Multi-Material Resource Recovery.....	46
--	----

## **PROCESS SYSTEMS ENGINEERING.....47**

Georgia Southern University Research and Service Foundation, Inc.: Feasibility Study of Coal Refuse and Biomass/Torrefied Biomass Co-Fired Power Plant: Performance, Cost and Environmental Impacts .....	47
Kansas State University: Modular Reactor for Co-Generation of Liquid Chemicals and Electricity from Stranded Natural Gas.....	48
Ohio State University: Co-Firing Switchgrass and Waste Coal in a Power Plant: A Techno-Economic and Life Cycle Evaluation for the Ohio River Valley .....	49
Pennsylvania State University: Electric Field Assisted Thermo-Catalytic Decomposition: Comparisons with Reaxff Atomistic Simulations .....	50
University of North Dakota: Non-Catalytic Pyrolysis of Associated Gas to Zero-CO <sub>2</sub> Hydrogen and High Value Carbon Black.....	51

## **SENSORS, CONTROLS, AND OTHER NOVEL CONCEPTS.....52**

Duke University: Characterization of Arsenic and Selenium in Coal Fly Ash to Improve Evaluations for Disposal and Reuse Potential .....	52
Michigan State University: High-Accuracy and High-Stability Fiber-Optic Temperature Sensors for Coal Fired Advanced Energy Systems .....	53
Ohio University: Enabling the Next Generation of Smart Sensors in Coal Fired Power Plants Using Cellular 5G Technology.....	54
Oklahoma State University: Towards AI-Enabled Autonomy of Robotic Inspection Platforms for Sustainability of Energy Infrastructure .....	55
University of Maryland: Robust Heat-Flux Sensors for Coal-Fired Boiler Extreme Environments .....	56
University of Massachusetts: Wireless High Temperature Sensor Network for Boiler Systems .....	57
University of North Dakota Energy and Environmental Research Center (UNDEERC): Incorporating Blockchain/P2P Technology into an SDN-Enabled Cybersecurity System to Safeguard Fossil Fuel Power Generation Systems.....	58
West Virginia University: An Autonomous Robotic Inspection System for Coal Ash and Tailings Storage Facilities.....	59
West Virginia University Research Corporation: Passive Wireless Sensors for Realtime Temperature and Corrosion Monitoring of Coal Boiler Components Under Flexible Operation .....	60

## **SIMULATION-BASED ENGINEERING ..... 61**

Carnegie Mellon University (CMU): Advanced Modeling and Process-Materials Co-Optimization Strategies for Swing Adsorption Based Gas Separations .....	61
Johns Hopkins University: Developing Drag Models for Non-Spherical Particles through Machine Learning .....	62

## **SOLVENTS .....63**

University of Wyoming: Systems Analysis for Advancing Coal/Waste Coal-Biomass Co-Firing Power Plants with Deep Carbon Capture, Utilization and Storage Toward Net-Zero Emissions .....	63
---	----

## **Abbreviations .....64**

## **Contacts.....67**

## UNIVERSITY TRAINING AND RESEARCH PROGRAM

The University Training and Research (UTR) program supports the Historically Black Colleges and Universities and other Minority Serving Institutions (HBCU–MSI) and the University Carbon Research (UCR) programs. The core mission of both programs is the following:

- To educate and train the next generation of engineers and scientists to help develop and contribute to a highly skilled, inclusive, and competitive U.S. workforce and economy
- To support novel, early-stage research at U.S. colleges and universities that advances the Office of Fossil Energy and Carbon Management’s (FECM) mission of delivering integrated solutions related to fossil energy and carbon management and enable transformation to a sustainable, low-carbon energy future
- To increase research and development (R&D) opportunities for traditionally underrepresented communities within the United States and tap into the innovative and diverse thinking of student researchers at HBCU–MSI institutions of higher learning
- To ensure that students are being equipped with cutting-edge, translatable skill sets that will allow them to contribute to the U.S. workforce and greater economy over the course of a long and enduring career.

Between 2010 and 2022, the UTR program made 146 R&D awards valued at more than \$52.59 million and helped to support more than 462 students at various stages in their academic careers, including undergraduate, master’s, and doctoral degree levels.

The UTR program annually conducts a nationwide competitive solicitation and awards R&D projects as grants with a typical duration of two to three years. This educational outreach initiative enhances the U.S. Department of Energy’s (DOE) ability to develop and sustain a national program of university research that trains the future workforce to reduce carbon emissions and to address the global challenges of climate change.

### FUNDAMENTAL AND APPLIED RESEARCH

The program provides a mechanism for cooperative research among universities (including MSIs) the private sector, and Federal agencies. The central thrust of the program is to generate fresh ideas, tap into unique talent, define applicable fundamental scientific principles, and develop advanced concepts for generating new and improved technologies across the full spectrum of fossil energy and carbon management R&D programs. Since its inception, the program has emphasized improving the capabilities of next-generation environmentally sustainable energy systems. The program supports FECM’s strategic vision of advancing justice, labor and engagement, carbon management approaches toward deep decarbonization, and technologies that lead to sustainable energy resources.

### ADVANCING JUSTICE, LABOR, AND ENGAGEMENT

A common thread running through all FECM programs, and a key focus of UTR is a commitment to incorporating justice principles throughout, including a just distribution of benefits and an emphasis on remediating legacy harms while mitigating new impacts. FECM will also implement, support, and expand robust labor engagement in disadvantaged communities, empowering them to implement place-based solutions that address their unique resources and needs.

### CURRENT RESEARCH THRUSTS

The University Training and Research program develops a wide array of technologies. Current development efforts are aligned with the FECM Strategic Vision:

- **Point-Source Carbon Capture (PSC):** reduce the cost, increase the efficacy, and advance deployment of commercial-scale PSC technologies in the power and industrial sectors
- **CO<sub>2</sub> Conversion:** accelerate capabilities for large-scale conversion of CO<sub>2</sub> into products advancing net-zero and justice goals, facilitated by markets for CO<sub>2</sub> as a feedstock

- **Carbon Dioxide Removal (CDR):** diverse approaches supporting DOE's Carbon Negative Shot, addressing emissions from hard-to-decarbonize sectors and eventually legacy emissions
- **Reliable Carbon Storage and Transport:** advance storage technologies and transport mechanisms and support large-scale transport and storage facilities and regional hubs
- **Gasification:** electromagnetic energy-assisted approaches to convert fossil fuels to low-cost hydrogen
- **Energy Asset Transformation:** flexible, efficient, and environmentally friendly fossil-based systems
- **Methane Mitigation:** minimize the environmental impacts of fossil energy extraction with a focus on methane emissions

**Table 1: UTR Key Technologies—AOIs (Active Projects as of October 1, 2023)**

<b>Key Technologies</b>	<b>Areas of Interest</b>	<b># of Projects</b>
Advanced Energy Materials	Electromagnetic Energy-Assisted Approaches to Convert Fossil Fuels to Low Cost Hydrogen	1
	Addressing High-Temperature Materials Supply Chain Challenges	2
	5G for Coal-Fired Power Generation	1
Algae	Biological Uptake of CO <sub>2</sub> Via Algae for Agricultural Applications	1
Carbon Utilization	Biological Uptake of CO <sub>2</sub> Via Algae for Agricultural Applications	1
Coal Ash Analysis	Phytotechnology Development for Identification and/or Remediation of Sites Exhibiting Soil Contamination via Groundwater Transport of Metals from Coal Combustion Product Impoundments	4
	R&D Scoping Study and Infrastructure Self-Assessment of Fossil Energy and Carbon Management Based Research Capabilities	1
	Resource Development Site Assessments to Inform Lifecycle Analysis /Techno-Economic Analysis	1
Energy Asset Transformation	Electromagnetic Energy-Assisted Approaches to Convert Fossil Fuels to Low Cost Hydrogen	1
Existing Fleet Modeling	Modeling Existing Coal Plant Challenges using High Performance Computing	1
	R&D Scoping Study and Infrastructure Self-Assessment of Fossil Energy and Carbon Management Based Research Capabilities	1
	Techno-Economic Analysis and Lifecycle Analysis Screening of Net-Zero or Net-Negative Greenhouse Gas Emission, Carbon Capture and Storage-Enabled, Coal/Waste Coal and Biomass Power Production	1
Humanities-driven Science, Technology, Engineering and Mathematics (HDSTEM)	Humanities-driven science (including social science), technology, engineering and mathematics to enhance the FECM University Training Research Programs	1

Key Technologies	Areas of Interest	# of Projects
Process Systems Engineering	Electromagnetic Energy-Assisted Approaches to Convert Fossil Fuels to Low Cost Hydrogen	3
	R&D Scoping Study and Infrastructure Self-Assessment of Fossil Energy and Carbon Management Based Research Capabilities	2
	Humanities-driven science (including social science), technology, engineering and mathematics	1
	Techno-Economic Analysis and Lifecycle Analysis Screening of Net-Zero or Net-Negative Greenhouse Gas Emission, Carbon Capture and Storage-Enabled, Coal/Waste Coal and Biomass Power Production	2
	Value-Added Natural Gas Conversion	2
Sensors, Controls, and Other Novel Concepts	Quantum for Energy Systems and Technologies	2
	Novel Sensors and Controls for Flexible Generation	5
	5G for Coal-Fired Power Generation	3
	Automated Component Inspection, Analysis, and Repair Enabled by Robotics	2
	Cybersecure Sensors for Fossil Power Generation	1
	Application of Novel Analytical Method(s) to Determine Arsenic and/or Selenium Concentrations in Fly Ash Waste Streams Generated from Coal Combustion	1
Simulation-Based Engineering	Machine Learning for Computational Fluid Dynamics	3
	Process and Materials Co-Optimization for the Production of Blue Hydrogen	1
Solvents	Techno-Economic Analysis and Lifecycle Analysis Screening of Net-Zero or Net-Negative Greenhouse Gas Emission, Carbon Capture and Storage-Enabled, Coal/Waste Coal and Biomass Power Production	1
Water Management	Energy-Water Nexus Implications and Opportunities of a Hydrogen Economy	1



## HISTORICALLY BLACK COLLEGES AND UNIVERSITIES AND MINORITY-SERVING INSTITUTIONS PROGRAM

For more than 30 years, NETL has supported the HBCU–MSI program, making it one of the longest-running university training initiatives within FECM. The key objective for HBCU–MSI program includes providing R&D opportunities for traditionally underrepresented populations in science, technology, engineering, and mathematics (STEM) fields. These activities align with the Biden Administration’s Justice40 Initiative, which seeks to advance environmental justice and revitalize the economies of disadvantaged communities.

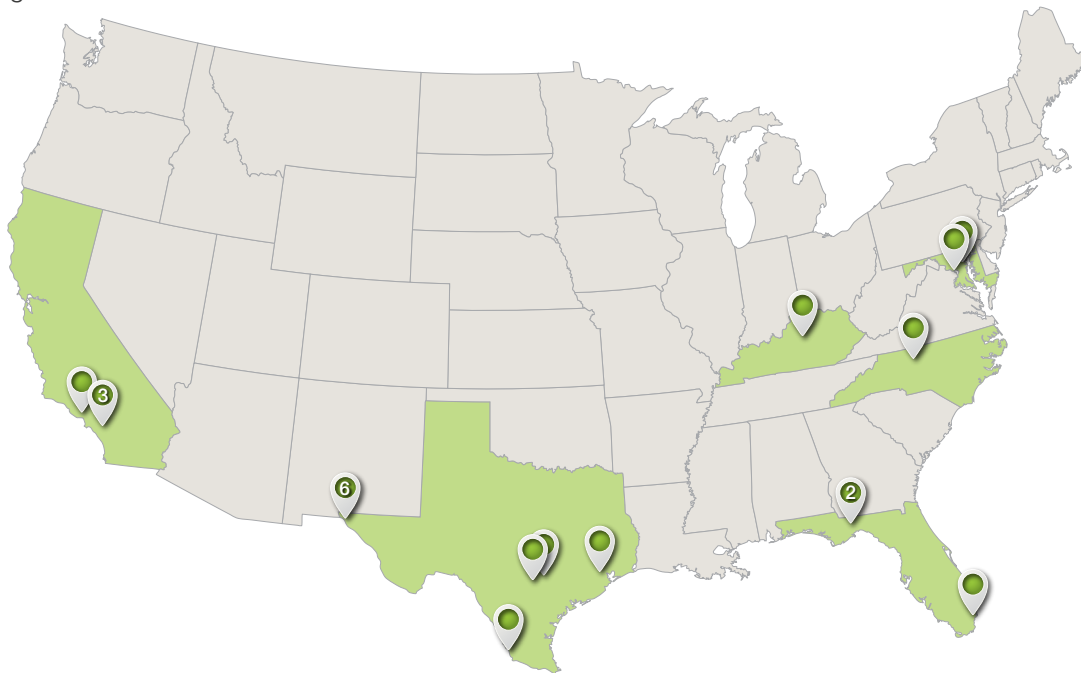

HBCU-MSI Participating Universities Locations  
(Active Projects as of October 1, 2023)

Table 2: HBCU-MSI Key Technologies—AOIs (Active Projects as of October 1, 2023)

Key Technologies	Areas of Interest	# of Projects
Algae	Biological Uptake of CO <sub>2</sub> Via Algae for Agricultural Applications	1
Carbon Utilization	Biological Uptake of CO <sub>2</sub> Via Algae for Agricultural Applications	1
Coal Ash Analysis	Phytotechnology Development for Identification and/or Remediation of Sites Exhibiting Soil Contamination via Groundwater Transport of Metals from Coal Combustion Product Impoundments	2
	R&D Scoping Study and Infrastructure Self-Assessment of Fossil Energy and Carbon Management Based Research Capabilities	1
Energy Asset Transformation	Electromagnetic Energy-Assisted Approaches to Convert Fossil Fuels to Low Cost Hydrogen	1

<b>Key Technologies</b>	<b>Areas of Interest</b>	<b># of Projects</b>
Existing Fleet Modeling	Modeling Existing Coal Plant Challenges using High Performance Computing	1
	R&D Scoping Study and Infrastructure Self-Assessment of Fossil Energy and Carbon Management Based Research Capabilities	1
Process Systems Engineering	Electromagnetic Energy-Assisted Approaches to Convert Fossil Fuels to Low Cost Hydrogen	2
	R&D Scoping Study and Infrastructure Self-Assessment of Fossil Energy and Carbon Management Based Research Capabilities	2
	Humanities-driven science (including social science), technology, engineering and mathematics	1
Sensors, Controls, and Other Novel Concepts	Quantum for Energy Systems and Technologies	2
	Novel Sensors and Controls for Flexible Generation	1
	5G for Coal-Fired Power Generation	2
Simulation-Based Engineering	Machine Learning for Computational Fluid Dynamics	2
Water Management	Energy-Water Nexus Implications and Opportunities of a Hydrogen Economy	1

# HISTORICALLY BLACK COLLEGES AND UNIVERSITIES AND MINORITY SERVING INSTITUTIONS (HBCU-MSI)

<b>ALGAE</b> .....	<b>13</b>
<b>University of California - Riverside:</b> An Experimental and Computational Approach to Investigating CO <sub>2</sub> Uptake of Cellulose-Producing Algae from Cellulosic Ethanol Product .....	13
<b>CARBON UTILIZATION</b> .....	<b>14</b>
<b>Prairie View A&amp;M University:</b> Producing Algal Biomass from Wastewater as Cotton Plant Fertilizer to Reduce Carbon Footprint .....	14
<b>COAL ASH ANALYSIS</b> .....	<b>15</b>
<b>Florida A&amp;M University:</b> Innovative Biomonitoring and Remediation of Heavy Metals Using Phytotechnologies at the Savannah River Site Coal Combustion Product Impoundment Sites.....	15
<b>Kentucky State University:</b> Mapping Soil Contamination from Coal Ash with Remote Sensing Analysis to Determine the Spatial Distribution and Impact on Soil Chemistry of Hyperaccumulator Plant Species .....	16
<b>Texas State University:</b> Infrastructure Assessment for Technology Innovation, Development and Training in Carbon Management.....	17
<b>ENERGY ASSET TRANSFORMATION</b> .....	<b>18</b>
<b>University of Texas at El Paso:</b> Microwave-Assisted Dehydrogenation of Fossil Fuels Using Iron-Based Alumina Nanocomposites.....	18
<b>EXISTING FLEET MODELING</b> .....	<b>19</b>
<b>Cal State L.A. University Auxiliary Services, Inc.:</b> R&D Scoping Study and Infrastructure Self-Assessment of Fossil Energy and Carbon Management Based Research Capabilities California State University.....	19
<b>North Carolina Agricultural and Technical State University:</b> Alloy for Enhancement of Operational Flexibility of Power Plants .....	20
<b>PROCESS SYSTEMS ENGINEERING</b> .....	<b>21</b>
<b>Howard University:</b> Multiphysics and Multiscale Simulation Methods for Electromagnetic Energy Assisted Fossil Fuel to Hydrogen Conversion .....	21
<b>University of California - Riverside:</b> Harnessing Plasma Experiments with Quantum Calculation for Low-Cost Hydrogen Production .....	22
<b>University of Texas at El Paso:</b> Capabilities Development at the University of Texas at El Paso for Hydrogen Generation Research and Education .....	23

<b>University of Texas at El Paso:</b> Overcoming Technical and Community Barriers to Adopting Gasification Technologies.....	24
<b>University of Texas Rio Grande Valley:</b> Assessment And Planning of Decarbonization Research and Training at University of Texas Rio Grande Valley .....	25
<b>SENSORS, CONTROLS, AND OTHER NOVEL CONCEPTS.....</b>	<b>26</b>
<b>Morgan State University:</b> Ceramic-Based Ultra-High Temperature Thermocouples in Harsh Environments .....	26
<b>University of California - Riverside:</b> Harnessing Quantum Information Science For Enhancing Sensors In Harsh Fossil Energy Environment .....	27
<b>University of Texas at El Paso:</b> Ultra-Low Disorder Graphene Quantum Dot-Based Spin Qubits for Cyber Secure Fossil Energy Infrastructure .....	28
<b>University of Texas at El Paso:</b> 5G Integrated Edge Computing Platform for Efficient Component Monitoring in Coal-Fired Power Plants .....	29
<b>University of Texas at El Paso:</b> 5G-Time Sensitive Networking Architecture Capable of Providing Real-Time Situational Awareness to Fossil-Energy (FE) Generation Systems .....	30
<b>SIMULATION-BASED ENGINEERING .....</b>	<b>31</b>
<b>Florida International University:</b> Development and Evaluation of a General Drag Model for Gas-Solid Flows Via Physics-Informed Deep Machine Learning.....	31
<b>University of Texas at San Antonio:</b> A General Drag Model for Assemblies of Non-Spherical Particles Created with Artificial Neural Networks .....	32
<b>WATER MANAGEMENT.....</b>	<b>33</b>
<b>Florida A&amp;M University:</b> Fossil Energy in the Hydrogen Economy - A Carbon-Water-Energy Nexus Adaptive Evaluation Platform.....	33

# An Experimental and Computational Approach to Investigating CO<sub>2</sub> Uptake of Cellulose-Producing Algae from Cellulosic Ethanol Product

<b>Performer</b>	University of California - Riverside
<b>Award Number</b>	FE0032207
<b>Project Duration</b>	10/01/2022 – 09/30/2024
<b>Total Project Value</b>	\$ 400,000
<b>FOA Number</b>	DE-FOA-0002598
<b>Area of Interest</b>	Biological Uptake of CO <sub>2</sub> Via Algae for Agricultural Applications

The overall goal of this project is to combine experimental algal cultures with predictive quantum calculations to evaluate system-level CO<sub>2</sub> uptake and conversion efficiency of cellulose-producing *Nannochloropsis* sp. algae. This project will (1) optimize *Nannochloropsis salina* (*N. salina*) cultures on effluent gas produced directly from cellulosic ethanol fermentation, (2) characterize the fermentation products, quantify cellulose production, and calculate CO<sub>2</sub> uptake efficiency with predictive quantum calculations, (3) conduct a life cycle and techno-economic analysis of the proposed integration, and (4) provide

training opportunities to the diverse body of minority students attending UC Riverside.

If successful, this approach could improve the understanding of a novel way to capture waste CO<sub>2</sub> from ethanol fermentation using algal cultures to produce microcrystalline cellulose. This project will enable a holistic educational experience for the researchers and students in this project to investigate algae-based agricultural benefits that serve as tangible examples of “real-life” research on clean energy processes and technologies.

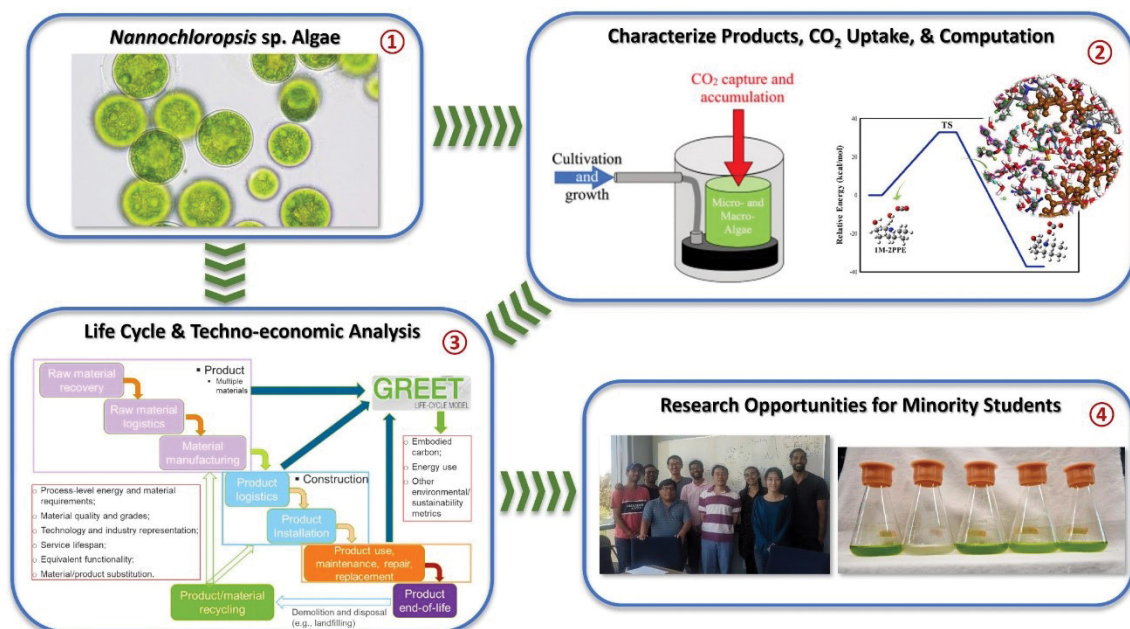

General project objectives.

## Producing Algal Biomass from Wastewater as Cotton Plant Fertilizer to Reduce Carbon Footprint

<b>Performer</b>	Prairie View A&M University
<b>Award Number</b>	FE0032203
<b>Project Duration</b>	01/01/2023 – 12/31/2024
<b>Total Project Value</b>	\$ 399,680
<b>FOA Number</b>	DE-FOA-0002598
<b>Area of Interest</b>	Biological Uptake of CO <sub>2</sub> Via Algae for Agricultural Applications

This project aims to investigate and develop how chemical fertilizer can be displaced with algal biomass for growing cotton plants to reduce the carbon footprint. For this purpose, the team will (1) add essential components in water to maximize the growth of algae in wastewater using the rotating algal biofilm reactor system; (2) use different spectroscopy and advanced imaging techniques to measure the carbon uptake and composition of algal biomass; (3) evaluate the algal biomass as biofertilizer for cotton plant growth under varying environmental conditions to reduce carbon footprint and (4) carry out cotton plant growth trials in test plots using varying amounts of algal biomass and evaluate the environmental and economic benefits. The

project will also carry out a detailed life cycle analysis and technoeconomic analysis for the entire process as per the guidelines of Bioenergy with Carbon Capture and Storage (BECCS).

If the project successfully demonstrates the benefits of using algal biomass as a biofertilizer to grow cotton plants, it will increase the TRL from 3 to 5. Additionally, the algal biomass biofertilizer could reduce root-knot nematode, alleviate drought stress to cotton plants, improve nutrient and carbon uptake and increase productivity, benefiting farmers. Lastly, this project will support graduate and undergraduate students to develop the skills of minority students in STEM disciplines.

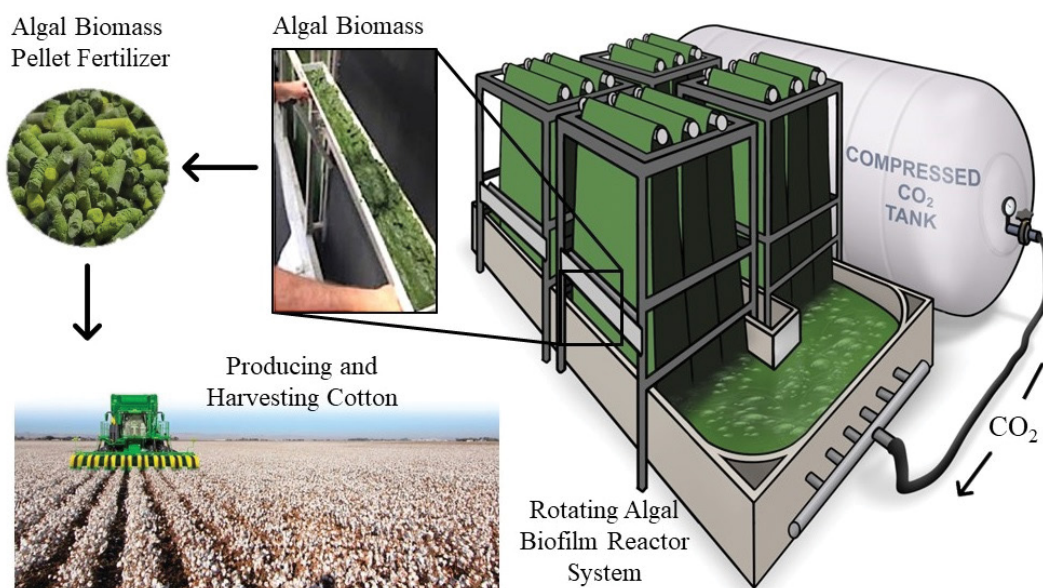

Utilization of algal biomass produced from wastewater with bubbling CO<sub>2</sub> as fertilizer for cotton plant.

# Innovative Biomonitoring and Remediation of Heavy Metals Using Phytotechnologies at the Savannah River Site Coal Combustion Product Impoundment Sites

<b>Performer</b>	Florida A&M University
<b>Award Number</b>	FE0032198
<b>Project Duration</b>	01/25/2023 – 01/24/2025
<b>Total Project Value</b>	\$ 399,528
<b>FOA Number</b>	DE-FOA-0002598
<b>Area of Interest</b>	Phytotechnology Development for Identification and/or Remediation of Sites Exhibiting Soil Contamination via Groundwater Transport of Metals from Coal Combustion Product Impoundments

The objective of the work by Florida A&M University is to utilize algal- and cyanobacterial-based phytotechnologies to address pervasive heavy metal contamination from coal combustion product impoundments at the Savannah River Site. Novel bioindicators will be developed to gauge the potential for phytoremediation to restore legacy impoundment sites. This will be achieved by conducting an environmental diagnostic assessment of ash pond sites, using metagenomics to identify taxonomic composition and gene functions of algal communities in sites with heavy metal contamination, developing an environmental health index of ash pond sites to predict the success of

remediation strategies, isolating algal-cyanobacterial taxa and screening them against heavy metals to confirm heavy metal resistance and/or hyperaccumulation, and populating artificial intelligence models to develop an iterative remediation strategy.

Phytotechnology could be a low-technology solution to remediate legacy coal ash impoundments. If the project demonstrates their effectiveness, algae and cyanobacteria could be applied to reduce the heavy metals concentration at other impoundments and reduce the risk of metals exposure for nearby communities and ecosystems.

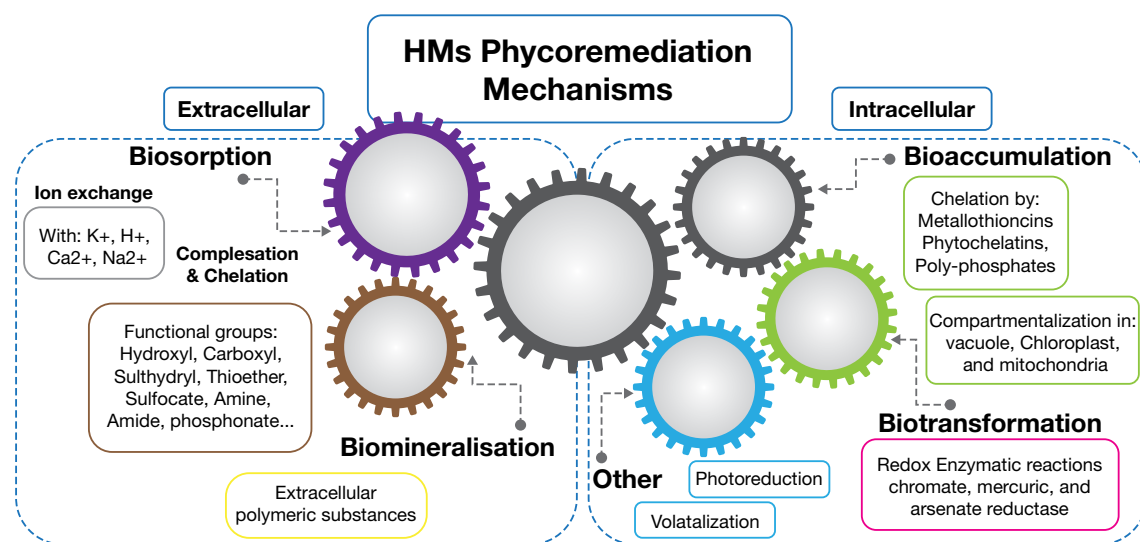

Mechanisms for phytoremediation of heavy metals.

## Mapping Soil Contamination from Coal Ash with Remote Sensing Analysis to Determine the Spatial Distribution and Impact on Soil Chemistry of Hyperaccumulator Plant Species

<b>Performer</b>	Kentucky State University
<b>Award Number</b>	FE0032197
<b>Project Duration</b>	02/01/2023 – 01/31/2026
<b>Total Project Value</b>	\$ 399,197
<b>FOA Number</b>	DE-FOA-0002598
<b>Area of Interest</b>	Phytotechnology Development for Identification and/or Remediation of Sites Exhibiting Soil Contamination via Groundwater Transport of Metals from Coal Combustion Product Impoundments

Kentucky State University, in collaboration with Lincoln University of Missouri and the University of Illinois, propose a project to map the distribution of soil contamination, groundwater composition, and spatial distribution of hyperaccumulator plant species by combining a comprehensive soil sampling program with GIS remote sensing methods to image and map changes in contaminant contents in the plants and soil.

This project will collect a large dataset on how certain plant species adapted and thrive on highly, polluted reclaimed sites. The data collected will be useful in establishing

relationships between bioaccumulation and plant tolerance. Second, this project will generate high-resolution (field-scale) and long-term (2023-2026) PPC maps for the target states (Illinois, Kentucky, and Missouri) using advanced drone and multi-satellite fusion data and deep learning algorithms for bioaccumulators. Third, once the team fully identifies and characterizes the dominant trees, shrubs and grass species at each contaminated sites, the information derived can be used to help formulate best management practices for the large-scale coverage at other similar affected areas elsewhere.



## Infrastructure Assessment for Technology Innovation, Development and Training in Carbon Management

<b>Performer</b>	Texas State University
<b>Award Number</b>	FE0032200
<b>Project Duration</b>	12/01/2022 – 07/15/2024
<b>Total Project Value</b>	\$ 239,485
<b>FOA Number</b>	DE-FOA-0002598
<b>Area of Interest</b>	R&D Scoping Study and Infrastructure Self-Assessment of Fossil Energy and Carbon Management Based Research Capabilities

The Texas State University (TXST) Carbon Transport and Storage Program will conduct an R&D scoping study and institutional self-assessment to evaluate how the capabilities and expertise as well as facilities and equipment at TXST

align with FECM's goals. This assessment will identify gaps in capabilities and provide discussion on what would enable the program to be better prepared for future competitive solicitations focused on FECM-supported technologies.

## Microwave-Assisted Dehydrogenation of Fossil Fuels Using Iron-Based Alumina Nanocomposites

<b>Performer</b>	University of Texas at El Paso
<b>Award Number</b>	FE0032086
<b>Project Duration</b>	08/15/2021 – 08/14/2024
<b>Total Project Value</b>	\$ 400,000
<b>FOA Number</b>	DE-FOA-0002398
<b>Area of Interest</b>	Electromagnetic Energy-Assisted Approaches to Convert Fossil Fuels to Low Cost Hydrogen

The primary goal of this research is to develop a microwave-assisted technology for low-cost production of hydrogen from fossil fuels. The research objectives are: (1) to determine optimal parameters of solution combustion synthesis (SCS) for the fabrication of iron-based alumina nanocomposites with superior catalytic activity, microwave absorptivity, and ferrimagnetic properties; (2) to determine the effectiveness of the iron-based alumina nanocomposites in the microwave-assisted catalytic decomposition of coal tar, crude oil, diesel fuel, and gasoline in terms of hydrogen selectivity and yield; and (3) to investigate regeneration of the iron-based alumina nanocomposites by microwave-assisted gasification of the formed carbon and by magnetic separation of the catalyst particles from the carbon byproducts.

The work will include fabrication of iron-based alumina nanocomposites by solution combustion synthesis using nitrates of iron and aluminum as the precursors and oxidizers. Citric acid will be used as the fuel. For optimization of the composition, morphology, and properties of the

nanocomposites, the Fe-Al and oxidizer-fuel ratios will be varied. For comparison, iron-based catalysts supported on silicon carbide (Fe/SiC) will be prepared by incipient wetness impregnation. There will be a study of microwave-assisted dehydrogenation of coal tar, crude oil, diesel fuel, and gasoline using the fabricated materials as microwave susceptors and catalysts, and the effectiveness of the iron-based alumina nanocomposites in terms of hydrogen selectivity and hydrogen yield will be determined and compared with that of the Fe/SiC catalysts.

The laboratory-scale studies will physically validate the effectiveness of the SCS-fabricated iron-based alumina nanocomposites in the main components of the proposed technology, namely, the microwave absorption, the catalytic effect, and the magnetic separation from carbon. Since the involved materials are abundant, inexpensive, and not toxic, the proposed method has the potential to become a competitive technology for hydrogen production from fossil fuels.

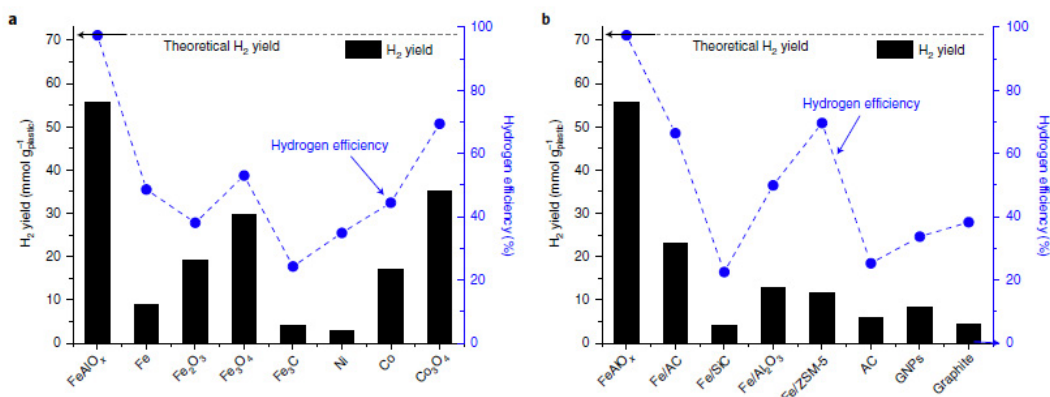

The effects of (a) different metal catalysts and (b) various supported iron catalysts and carbons on the H<sub>2</sub> yield and hydrogen efficiency.

## R&D Scoping Study and Infrastructure Self-Assessment of Fossil Energy and Carbon Management Based Research Capabilities California State University

<b>Performer</b>	Cal State L.A. University Auxiliary Services, Inc.
<b>Award Number</b>	FE0032202
<b>Project Duration</b>	12/31/2022 – 12/30/2023
<b>Total Project Value</b>	\$ 200,000
<b>FOA Number</b>	DE-FOA-0002598
<b>Area of Interest</b>	R&D Scoping Study and Infrastructure Self-Assessment of Fossil Energy and Carbon Management Based Research Capabilities

The overarching goal of this R&D scoping study and self-assessment was to evaluate how the current research capability and educational activities of California State University, Los Angeles (CSULA) can be expanded to align with the DOE/FECM objectives. CSULA will also identify gaps in research and education capability and develop strategies to enable CSULA to be competitive for future solicitations focused on FECM-supported technologies.

This overarching goal was realized through the following specific objectives:

1. Identify existing university research thrust areas that are synergistic with FECM mission goals and assess the current capabilities and resources, including personnel, expertise, awards, and facilities/equipment, in the identified areas.
2. Determine the resource needs (gaps) to enable competitive standing in future FECM research opportunities.
3. Describe CSULA's current student education and training activities, including current academic courses, programs, and curricula, that align with FECM goals (decarbonization).
4. Discuss additional needs to enhance the education and training of minority students from underrepresented and structurally marginalized communities.
5. Assess the potential for national and international collaborations on research and education in decarbonization.

This study will enable CSULA to compete for future research opportunities and successfully obtain funding from DOE and other funding agencies to conduct FECM-related early-stage research and development activities to attain decarbonization goals. The assessment may also enhance the education and training of underrepresented students from disadvantaged/ minority communities by increasing the number of students trained and improving student recruitment and retention.

## Alloy for Enhancement of Operational Flexibility of Power Plants

<b>Performer</b>	North Carolina Agricultural and Technical State University
<b>Award Number</b>	FE0031747
<b>Project Duration</b>	08/15/2019 – 12/31/2023
<b>Total Project Value</b>	\$ 400,000
<b>FOA Number</b>	DE-FOA-0001991
<b>Area of Interest</b>	Modeling Existing Coal Plant Challenges using High Performance Computing

North Carolina Agricultural and Technical State University employed advanced computational techniques to address the challenge of higher material deterioration facing the existing coal-fired power plants due to a shift in their operational mode from baseline steady state to cycling. The cycling operation of coal-fired power plants promotes thermo-mechanical fatigue damage in boiler headers. As a result, materials deteriorate at a higher rate and ligament cracking occurs in headers in a shorter time. The main objective of this project was to employ computational fluid dynamics and finite element analysis to conduct a comprehensive and advanced study of the applicability of

Inconel (IN) 740H superalloy in steam headers to improve the operating flexibility of power plants. The project team used the results of the analysis to optimize the geometry of headers to minimize the quantity of material used.

A cost-benefit analysis of headers designed with IN740H (employing both traditional and optimized shapes) in comparison with creep-strength-enhanced ferritic (CSEF) steels such as Grade 91 will be conducted. This analysis considered the higher cost of IN740H with respect to CSEF steels and the lower maintenance cost of IN740H during operation of the power plant.

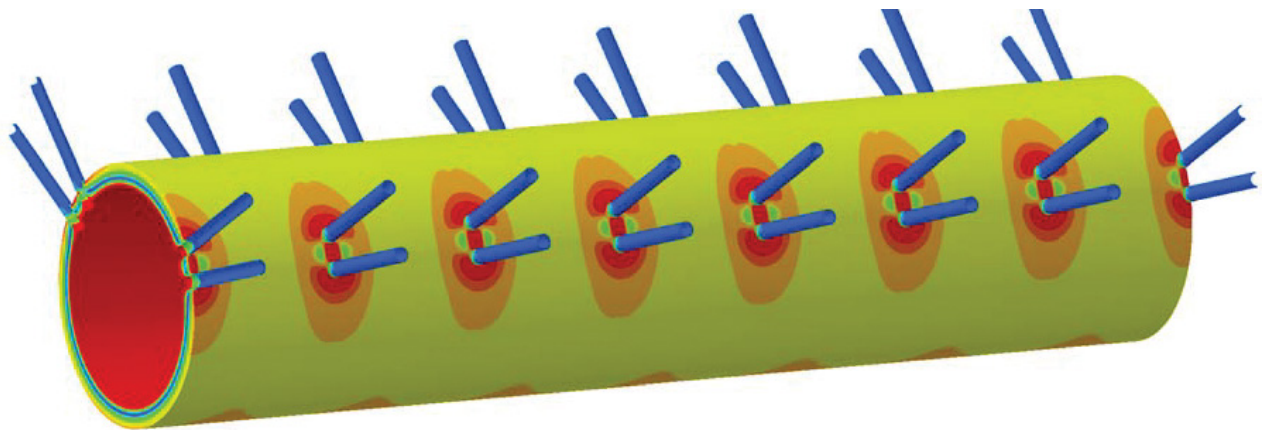

Stress contour plot of a steam header.

# Multiphysics and Multiscale Simulation Methods for Electromagnetic Energy Assisted Fossil Fuel to Hydrogen Conversion

<b>Performer</b>	Howard University
<b>Award Number</b>	FE0032092
<b>Project Duration</b>	09/01/2021 – 08/31/2024
<b>Total Project Value</b>	\$ 399,935
<b>FOA Number</b>	DE-FOA-0002398
<b>Area of Interest</b>	Electromagnetic Energy-Assisted Approaches to Convert Fossil Fuels to Low Cost Hydrogen

This project will develop and apply multiphysics and multiscale simulation methods for efficient electromagnetic (EM) energy assisted conversion from fossil fuel to low-cost hydrogen. This will entail the development and investigation of computational methods in two major thrust areas:

1. Modeling and simulation methods for coupled multiphysics phenomena involving EM, plasma physics, thermal and fluid dynamics, and quantum chemistry across multiple spatial scales from macro and meso to microscopic scales, and temporal scales from nanoseconds to minutes.
2. Simulation-guided designs for EM energy assisted high-throughput, high-yield, and low-cost hydrogen

generation from fossil fuels such as methane and methanol.

Together, these will be used to target four specific objectives: (1) understanding 3D structures of catalysts and their supports; (2) characterization of EM hotspots within heterogeneous catalysis; (3) multiphysics investigation of EM energy assisted catalytic active sites enhancement; and (4) system design and optimization for high-yield and low-cost hydrogen generation.

By developing advanced multiphysics and multiscale simulation methods, the fossil fuel-to-hydrogen conversion process can be optimized for both higher yields and lower costs.

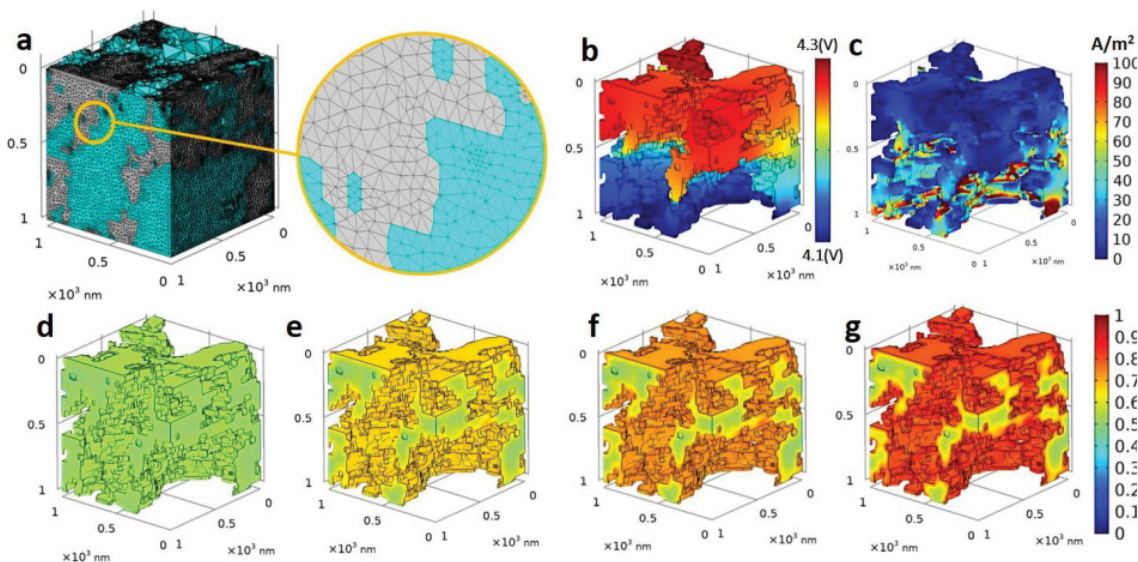

Example of a successful multiphysics simulation of solid-state battery performed by the PI. The same type of simulation will be performed for EM assisted conversion of fossil fuels to hydrogen through the use of a solid-state catalyst. The size of the simulated battery is 1  $\mu\text{m}$  cubic. a. mesh. b-c. potential and current distribution. d-g. the state of charge at different potentials.

## Harnessing Plasma Experiments with Quantum Calculation for Low-Cost Hydrogen Production

<b>Performer</b>	University of California - Riverside
<b>Award Number</b>	FE0032091
<b>Project Duration</b>	08/18/2021 – 08/17/2024
<b>Total Project Value</b>	\$ 400,000
<b>FOA Number</b>	DE-FOA-0002398
<b>Area of Interest</b>	Electromagnetic Energy-Assisted Approaches to Convert Fossil Fuels to Low Cost Hydrogen

In response to the pressing need for improved technologies for clean hydrogen generation, this project will combine experiment and ab-initio quantum calculations in order to understand the interaction between methane-containing plasma and a carbon-based catalyst. Predictive quantum calculations for the case of a methane plasma impinging onto a carbon surface will be performed, in addition to in-situ diagnostic techniques to experimentally characterize the interaction between the plasma and the carbon surface. These results of both computation and experiment will be

used to leverage the design of an improved process for the plasma-driven pyrolysis of methane for low-cost hydrogen production.

The prospect of activating graphite as a catalyst for the decomposition of methane into hydrogen would open the possibility of leveraging a readily available resource such as coal to enable a cost-effective process for the production of hydrogen from natural gas which is cost competitive with water electrolysis.

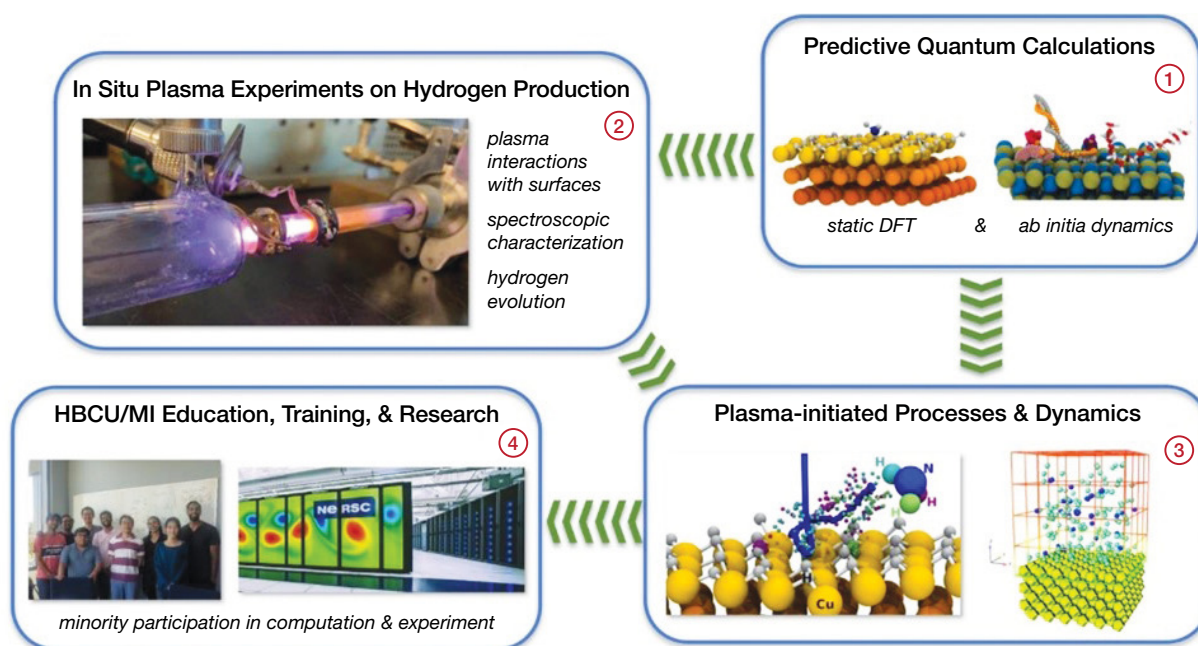

Overall scope and approach for utilizing plasma experiments and quantum calculations for low-cost hydrogen production from fossil fuels.

## Capabilities Development at the University of Texas at El Paso for Hydrogen Generation Research and Education

<b>Performer</b>	University of Texas at El Paso
<b>Award Number</b>	FE0032201
<b>Project Duration</b>	01/01/2023 – 12/31/2023
<b>Total Project Value</b>	\$ 200,000
<b>FOA Number</b>	DE-FOA-0002598
<b>Area of Interest</b>	R&D Scoping Study and Infrastructure Self-Assessment of Fossil Energy and Carbon Management Based Research Capabilities

The overarching goal of the effort was to assess the R&D capability of the university to develop a research-scale modular high-pressure municipal solid waste (MSW) gasifier for H<sub>2</sub> production and plan towards the transition to hydrogen energy systems research. The R&D scoping of a modular gasifier was conducted at the energy division of the Aerospace Center (cSETR) at the University of Texas at El Paso (UTEP). The effort was focused on analysis of the current state of the art, technology gap analysis, capability assessment and planning toward H<sub>2</sub> research facility development, and student training on gasifier design

analysis and modeling of MSW gasifier for H<sub>2</sub> production.

The effort paves the way for developing a cutting-edge hydrogen research facility, adding a new facet to the Aerospace Center's carbon-neutral energy research. The new facility will explore various solutions for hydrogen production through the gasification of MSW, biomass, legacy wastes, and combinations of these sources. In addition to the research effort, the introduction of the new facility and the development of graduate-level coursework will produce a skilled energy workforce for next-generation energy systems in the El Paso area.

## Overcoming Technical and Community Barriers to Adopting Gasification Technologies

<b>Performer</b>	University of Texas at El Paso
<b>Award Number</b>	FE0032237
<b>Project Duration</b>	07/01/2023 – 06/30/2026
<b>Total Project Value</b>	\$ 750,000
<b>FOA Number</b>	DE-FOA-0002598
<b>Area of Interest</b>	Humanities-driven science (including social science), technology, engineering and mathematics

The proposed effort seeks to demonstrate a 300 kWth pilot-scale fluidized bed co-gasifier for municipal solid waste (MSW) and biomass. The project will investigate the interrelation between gasifier operating conditions (pressure, temperature, gasifying agent, residence time) and feedstock parameters (feedstock constituents, blending ratio, moisture content, particle size) to improve hydrogen production, syngas quality, and efficiency. The research team will conduct a techno-economic analysis and a life cycle analysis. Subsequent optimization will consider multiple parameters including feedstock variables and post-gasification processes including carbon capture and storage. Comparison with other gasification processes for MSW will determine the economic feasibility and the carbon footprint reduction capabilities of a commercial-scale project.

Adoption of new technologies intended to combat climate change requires persuasive messaging and a communications strategy intended to educate policy makers and community members about the benefits.

Engineering students working on developing and testing these new gasification technologies will work with UTEP's Sam Donaldson Center for Communications Studies on messaging centered around the advantages of adopting co-gasification technologies that recycle MSW and biomass for use in hydrogen production.

This effort supports research and development for collaborative work in STEM fields with an enhanced focus on social science and humanities components that lead to interdisciplinary learning, sustainable technology deployment, and education within the community.

Hydrogen production coupled with carbon capture and storage (CCS) and sustainably sourced carbon-based feedstocks (e.g., biomass, fossil fuels and plastics, including wastes) is a potentially critical component of a new green energy economy. Once produced, hydrogen can be used to generate electrical power in a fuel cell with water as the primary byproduct. Therefore, it has the potential to reduce greenhouse gas emissions in transportation and can help enhance energy security by diversifying energy options.

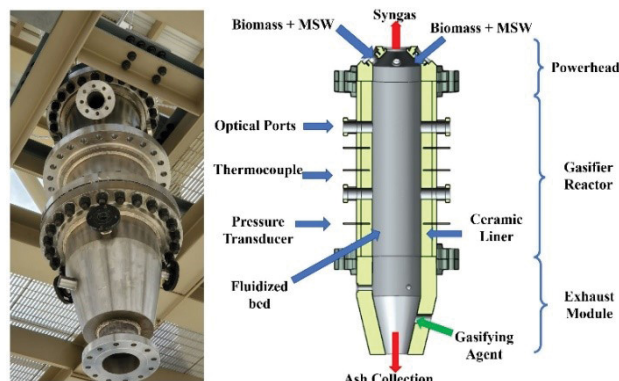

Gasifier with associated schematic diagram.



## Assessment and Planning of Decarbonization Research and Training at University of Texas Rio Grande Valley

<b>Performer</b>	University of Texas Rio Grande Valley
<b>Award Number</b>	FE0032199
<b>Project Duration</b>	01/01/2023 – 08/31/2024
<b>Total Project Value</b>	\$ 200,000
<b>FOA Number</b>	DE-FOA-0002598
<b>Area of Interest</b>	R&D Scoping Study and Infrastructure Self-Assessment of Fossil Energy and Carbon Management Based Research Capabilities

University of Texas Rio Grande Valley (UTRGV) is conducting an R&D scoping study and university self-assessment to evaluate how the current capabilities, expertise, and facilities align with the U.S. Department of Energy's Office of Fossil Energy and Carbon Management (FECM) objectives. Gaps in capabilities and plans to better prepare UTRGV for potential future competitive solicitations focused on FECM-supported technologies will be considered.

The project will develop a student training and education plan to ensure that UTRGV's minority students are prepared to conduct R&D projects. Current academic courses and programs that align with FECM goals will be assessed in order to identify, describe, and develop additional student training. Aligned with this, partner institution Louisiana State

University will provide support for student training, including a specialized course on decarbonization, to fill the gaps in UTRGV's curriculum in a timely manner. Throughout this project, the team will utilize underrepresented students at UTRGV to conduct the assessment study, while also providing them with specialized training to strengthen their research skills.

This project will help to develop UTRGV curricular offerings to better prepare minority students for conducting R&D within the FECM program umbrella and will identify ways in which FECM may support the professional development of students from underrepresented and structurally marginalized communities of Rio Grande Valley.

## Ceramic-Based Ultra-High Temperature Thermocouples in Harsh Environments

<b>Performer</b>	Morgan State University
<b>Award Number</b>	FE0031906
<b>Project Duration</b>	08/01/2020 – 07/31/2024
<b>Total Project Value</b>	\$ 500,000
<b>FOA Number</b>	DE-FOA-0002193
<b>Area of Interest</b>	Flexible Fossil Power Generation

Researchers will develop novel, durable, low cost, ceramic-based super-high-temperature thermo-couples (up to 2000 °C) for use in high-temperature (750–1800 °C) and 1000 PSI and above coal-based energy systems under high corrosion and erosion conditions. The materials, zirconium diboride ( $ZrB_2$ ) and samarium hexaboride ( $SmB_6$ ) thermoelectric refractory materials will be employed as n- and p-type thermocouple legs. The materials will be compacted into isotropic thermoelectric nanocomposites as thermocouple legs with excellent Seebeck coefficient. The legs will be fabricated into ceramic-based thermocouples with p-n junctions. The thermocouples will also have good oxidization and sulfidization resistance, no protective outer layer, and cost less than acoustic and optical devices. Thermocouple performance will be evaluated in oxygen, carbon oxide, and sulfide atmospheres at high

pressure and temperature. In addition, the effects of heat flow, flow rate, and mass flux found in coal power generation on the performance of the thermocouples will be investigated. Physical behaviors and long-term stability will be evaluated.

Accurate and reliable temperature measurements and controls are essential to operating coal-based energy systems at high efficiency and optimal performance. However, present thermosensors, utilizing expensive acoustic and optical techniques usually do not work well under such harsh conditions. Development and application of new kinds of thermocouples are essential elements for low-cost maintenance and long-term stable thermo-sensing devices. The proposed ceramic based super-high-temperature thermocouples will lead to the development of low-cost thermosensors and significant reduction in maintenance costs.

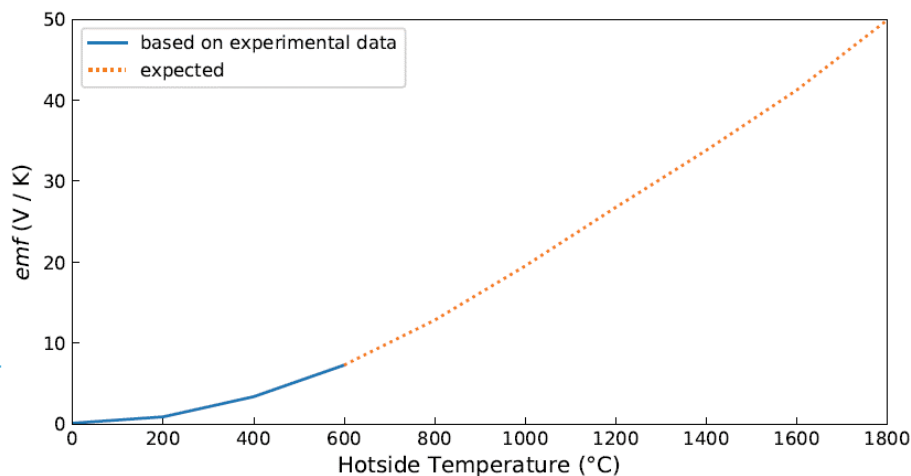

Expected emf of  $ZrB_2$ - $SmB_6$  thermocouples.

## Harnessing Quantum Information Science For Enhancing Sensors In Harsh Fossil Energy Environment

<b>Performer</b>	University of California - Riverside
<b>Award Number</b>	FE0031896
<b>Project Duration</b>	09/20/2020 – 03/19/2025
<b>Total Project Value</b>	\$ 500,000
<b>FOA Number</b>	DE-FOA-0002193
<b>Area of Interest</b>	Quantum Energy Systems and Technologies

The project plans to utilize real-time quantum dynamics simulations and quantum optimal control algorithms to (1) harness near-surface nitrogen vacancy (NV) centers to detect chemical analytes in harsh fossil energy environments and (2) design optimally constructed electromagnetic fields for initializing these near-surface NV center spins for efficient sensor performance and detection. Together, these objectives will leverage quantum information science

to enable new sensing modalities for extremely sensitive monitoring (i.e., below classical measurement limits) of critical operating parameters of fossil energy infrastructures in harsh environments. Quantum information science is leveraged to enable new sensing modalities for the extremely sensitive monitoring (i.e., below classical measurement limits) of critical operating parameters of fossil energy infrastructures in harsh environments.

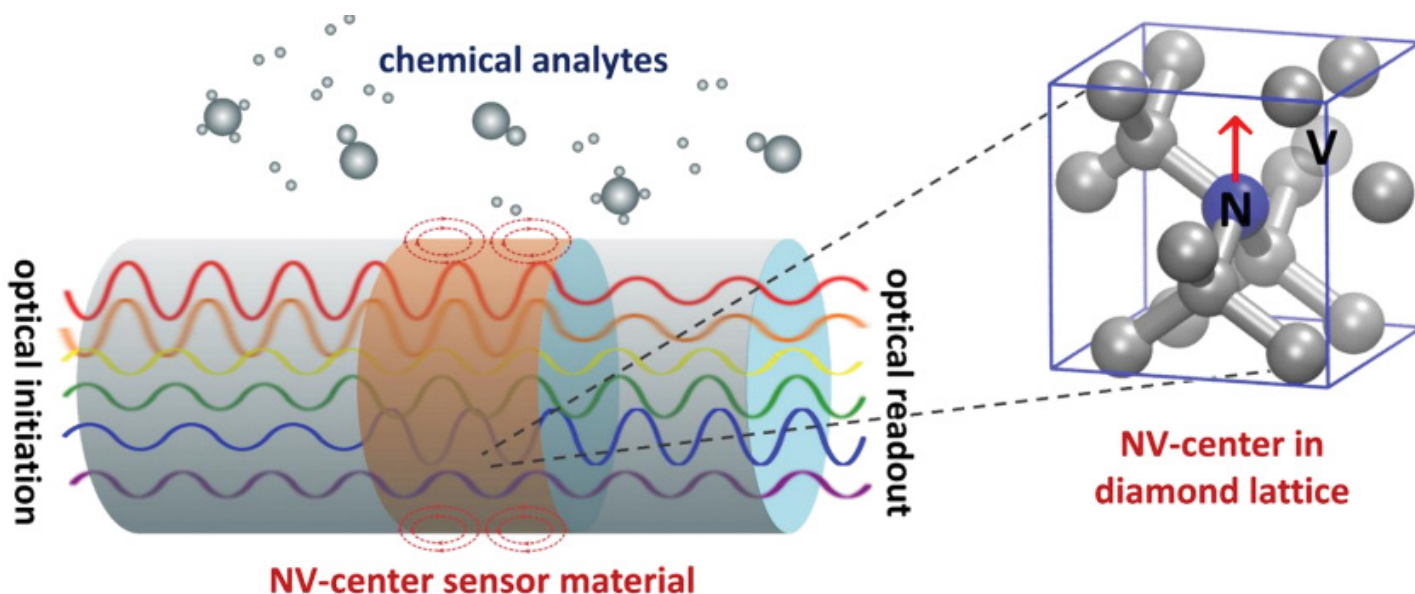

Improving sensing modalities in fossil energy infrastructures.

## Ultra-Low Disorder Graphene Quantum Dot-Based Spin Qubits for Cyber Secure Fossil Energy Infrastructure

<b>Performer</b>	University of Texas at El Paso
<b>Award Number</b>	FE0031908
<b>Project Duration</b>	09/01/2020 – 02/28/2025
<b>Total Project Value</b>	\$ 499,546
<b>FOA Number</b>	DE-FOA-0002193
<b>Area of Interest</b>	Quantum Energy Systems and Technologies

The specific research objectives of the project will be to define graphene quantum dots (GQDs) on graphene nanoribbon (GNR) with ultralow local defects and characterize the edge roughness and local disorder by diverse microscopic and spectroscopic techniques; conduct low-temperature characterization of quantum transport and spin relaxation times in GQDs to evaluate the effect of lower local disorder; and develop a multi-GQD-based qubit platform and analyze coupling effects and performance improvements achieved through the new synthetic protocols for quantum communication applications. To achieve the objectives, the team will first leverage the nanotomy technique to prepare GNRs of various widths and characterize its superiority by comparing their structural and disorder status with lithographically prepared GNRs (which will function as the baseline in the project). Subsequently, scanning probe microscopy-based oxidation lithography (SPM-OL) will be used to fabricate geometrically confined GQDs with tunnel barriers on the GNRs. Then the team will fabricate electrode patterns that connect the quantum dots to source and drain electrodes.

An in-depth study will be conducted characterizing the local

density of states and conductance of the GQDs with variable widths. Cumulatively, these studies will help in developing an optimized GQD qubit system fabricated using nanotomy and SPM-OL. Quantum transport and spin relaxation measurements conducted at mK temperatures will reveal the superiority of the present GQDs with ultralow defects. Further, the optimized GQD fabrication process will be extended to develop an array of GQDs integrated with local gate electrodes and quantum point contact to study the inter-dot coupling effects in the GQD arrays.

The primary benefit of the project is that it will result in a significantly improved strategy to formulate GQD qubits (individual and multi-GQDs) with ultralow local defects and higher spin relaxation times ( $> \mu$ -seconds). The development of such GQD platforms is expected to advance state-of-the-art graphene quantum structure fabrication technologies and semiconductor spin qubits. This project will also be beneficial for ongoing research efforts to develop highly secured communication systems and thus enable the implementation of GQD spin qubits in quantum processors for cyber-resilient grid infrastructure.

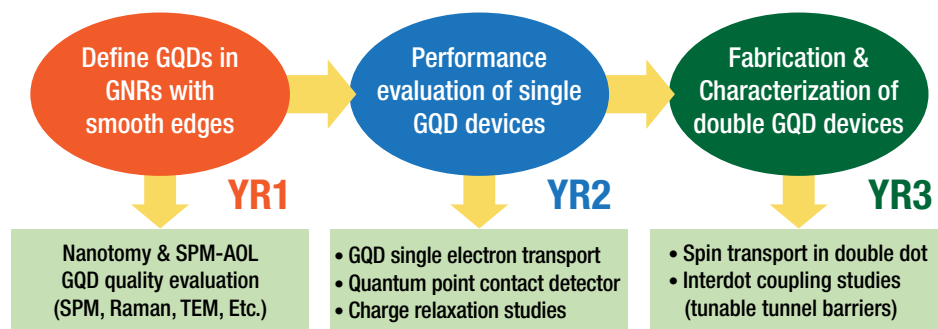

Outline of the overall effort of the proposed project.

## 5G Integrated Edge Computing Platform for Efficient Component Monitoring in Coal-Fired Power Plants

<b>Performer</b>	University of Texas at El Paso
<b>Award Number</b>	FE0032089
<b>Project Duration</b>	08/23/2021 – 08/22/2024
<b>Total Project Value</b>	\$ 400,000
<b>FOA Number</b>	DE-FOA-0002398
<b>Area of Interest</b>	5G for Coal-Fired Power Generation

The goal of this project is to develop a 5G integrated distributed edge computing framework that facilitates real-time monitoring of critical components in coal-fired power plants (CFPPs). The objectives are as follows:

1. Distributed edge computing service (DECS) orchestration for CFPP component monitoring – Develop an on-demand distributed edge computing platform to gather, process, and efficiently analyze the component health data in the CFPPs.
2. Deploy and integrate 5G networking to enable QoS (quality of service)-aware network slicing – Leverage software-defined networking and network function virtualization mechanisms of 5G to instantiate a logically separated component monitoring network slice that will be integrated with DECS for time-sensitive and efficient transfer of CFPP component health data.
3. Prototype development and empirical evaluation – Develop a customizable 5G-capable distributed edge computing prototype with a separate network slice for efficient plant component monitoring. In addition, extensive performance evaluation of the developed platform will be conducted by measuring several critical metrics.

The project will involve development of a reconfigurable prototype for efficient component monitoring in CFPPs using cutting-edge 5G and edge computing technology. This technology could be used to monitor the health of the components of any power plant in real time allowing for quicker detection and replacement of worn components

with reduced downtime and a reduced need for manual monitoring. The proposed system is an improvement over current solutions due to its underlying resource virtualization and reconfigurability characteristics. This will allow plant operators to dynamically instantiate and manage the QoS needs of the component monitoring traffic in real time. This platform would inherently enhance resiliency of the SCADA network because of the network slicing functionality.

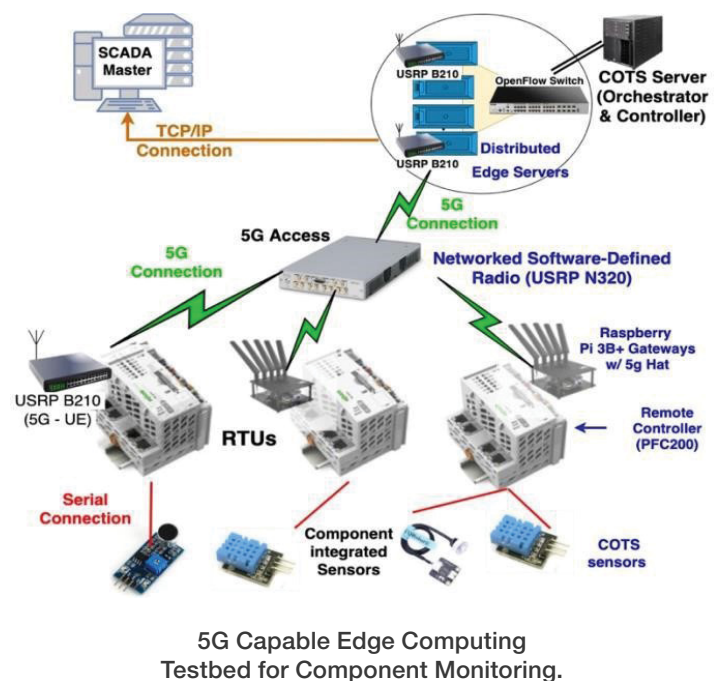

## 5G-Time Sensitive Networking Architecture Capable of Providing Real-Time Situational Awareness to Fossil-Energy (FE) Generation Systems

<b>Performer</b>	University of Texas at El Paso
<b>Award Number</b>	FE0032090
<b>Project Duration</b>	09/23/2021 – 09/22/2024
<b>Total Project Value</b>	\$ 400,000
<b>FOA Number</b>	DE-FOA-0002398
<b>Area of Interest</b>	5G for Coal-Fired Power Generation

The overall goal of the project is the delivery of an integrated fifth-generation time-sensitive networking architecture (5G-TSN) capable of supporting coal-fired power generation systems' operational data while providing the required deterministic quality of service. Requirements formulation and design will be based on a thorough network performance and emitted electromagnetic interference (EMI) characterization of the University of Texas at El Paso (UTEP) Center for Space Exploration and Technology Research (cSETR) pressurized oxy-coal combustion system and the high-pressure oxy-natural-gas combustor. Recorded data and EMI profiles will then be played back into an end-to-end (E2E) simulation of the 5G-TSN network. The proposed research will demonstrate the ability to design a 5G-TSN network capable of providing the necessary quality of service and security for measurement and control of an oxy-coal and oxy-natural gas combustor systems. The UTEP team will advance this technology by simulating end-to-end live combustor data through a 5G-TSN network. The goal will be fulfilled by the following specific objectives: (i)

operational characterization of the pressurized oxy-coal combustion system, (ii) 5G-TSN integration requirements and conceptual design, and (iii) E2E simulation of oxy-coal combustion SCADA onto 5G-TSN ontology.

As power plants evolve, the ability to monitor them in real time is critical to increasing their efficiency and minimizing down time due to maintenance and repairs. Fifth-generation networks established in the harsh operating conditions can give operators a way to monitor equipment that have needed to be shut down for inspection and proactive response to maintenance issues. The effort undertaken in this body of work will aim to characterize and deliver a novel 5G-TSN architecture capable of critical control and real-time measurement. The proposed design will be validated not only through industry-standard simulation but through the characterization of a pilot-scale oxy-coal combustor system during the course of this project. The introduction of a physical system to an otherwise simulated environment paves the way to practical implementation of 5G-TSN networks.

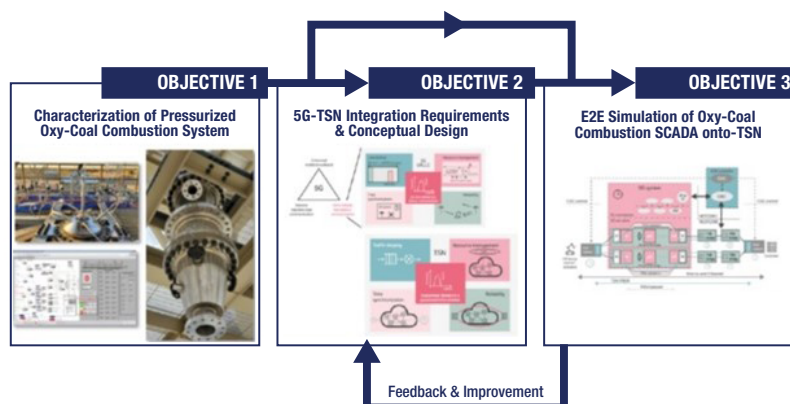

Schematic flowchart showing the overarching objectives of the project.

# Development and Evaluation of a General Drag Model for Gas-Solid Flows Via Physics-Informed Deep Machine Learning

<b>Performer</b>	Florida International University
<b>Award Number</b>	FE0031904
<b>Project Duration</b>	08/01/2020 – 07/31/2024
<b>Total Project Value</b>	\$ 500,000
<b>FOA Number</b>	DE-FOA-0002193
<b>Area of Interest</b>	Machine Learning for Computational Fluid Dynamics

The objective of this project is to develop, test, and validate a general drag model for multiphase flows in assemblies of non-spherical particles by a physics-informed deep machine learning approach using an artificial neural network (ANN). Once implemented in computational fluid dynamics (CFD) code, the model aims to accurately predict a particle's drag coefficient and flow fields in the simulation of gas-particle flows, with a wide range of parameters including Reynolds number, Stokes number, solid volume fractions, particle densities, particle orientations, and particle aspect ratios. The project will involve the following research and development activities: (1) data collection and generation of drag coefficients for non-spherical particles; (2) ANN-based drag model development through deep learning neural networks (DNN), algorithm identification and evaluation,

and model tests using different data sets; (3) integration of the best DNN model into NETL's open-source CFD software MFIX-DEM; and (4) validation of selected multiphase flows using the new drag model. Completion of the project will result in a deep machine learning-based general drag model for non-spherical particles in gas-solid flow simulation by CFD. The general drag model will overcome the limitations of existing models, which are problem specific and work only within narrow parameter ranges. This research project provides the students and faculty at Florida International University, a minority-serving institution, great opportunity to work on cutting-edge research related to applications of emerging machine learning technologies in gas-particle multiphase flows.

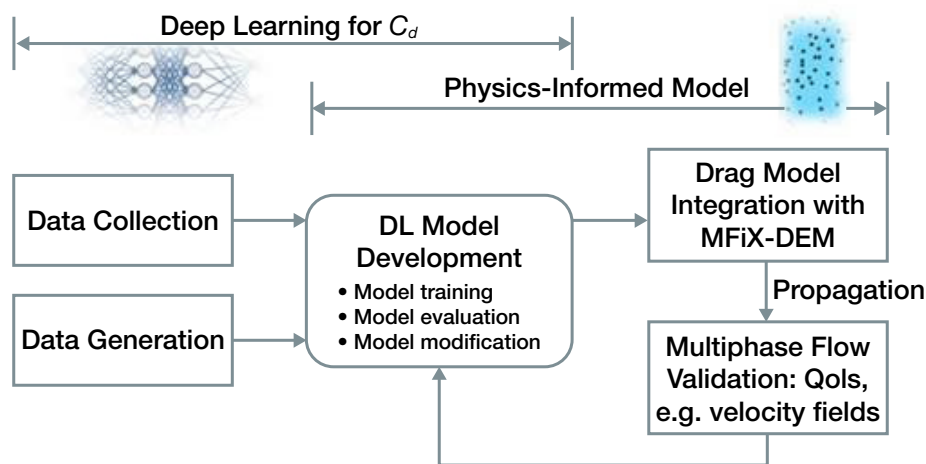

A physics-informed deep learning framework for a drag coefficient model.

## A General Drag Model for Assemblies of Non-Spherical Particles Created with Artificial Neural Networks

<b>Performer</b>	University of Texas at San Antonio
<b>Award Number</b>	FE0031894
<b>Project Duration</b>	09/01/2020 – 08/31/2024
<b>Total Project Value</b>	\$499,982
<b>FOA Number</b>	DE-FOA-0002193
<b>Area of Interest</b>	Machine Learning for Computational Fluid Dynamics

The project plans to develop a more accurate artificial neural network (ANN)-based method for modeling the momentum exchange in fluid-solid multiphase mixtures to significantly improve the accuracy and reduce the uncertainty of multiphase numerical codes and, in particular, of MFIX by developing and providing a general and accurate method for determining the drag coefficients of assemblies of non-spherical particles for wide ranges of Reynolds numbers, Stokes numbers, and fluid-solid properties and characteristics. The research team will achieve this aim by conducting numerical computations with a validated in-house CFD code and using artificial intelligence methods to

develop an ANN that will be implemented in TensorFlow™ and linked with the MFIX code. The main objectives of this project are to use a validated computational fluid dynamics (CFD) code to perform computations and to derive accurate expressions for the drag coefficients of single non-spherical particles and assemblies of non-spherical particles for wide ranges of the parameters of interest. A second objective of the work is to educate and train several graduate and undergraduate students in the science of multiphase flow and the use of in-house CFD codes, the MFIX code, and TensorFlow.

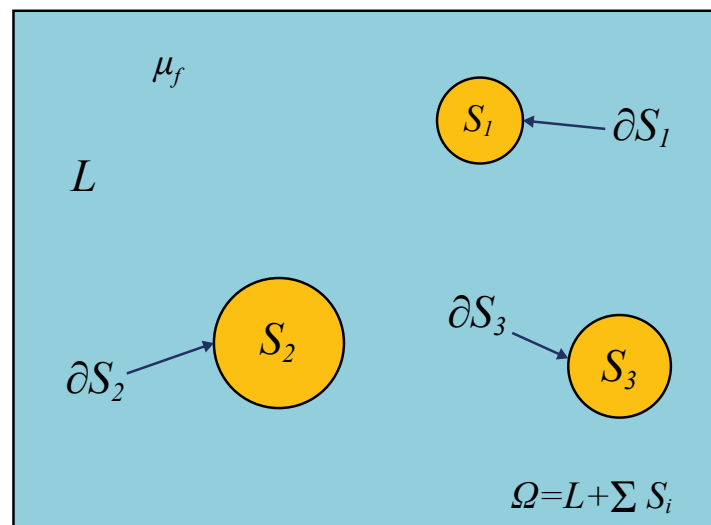

Conceptual model of three particles suspended in a fluid.



# Fossil Energy in the Hydrogen Economy - A Carbon-Water-Energy Nexus Adaptive Evaluation Platform

<b>Performer</b>	Florida A&M University
<b>Award Number</b>	FE0032084
<b>Project Duration</b>	07/16/2021 – 07/15/2024
<b>Total Project Value</b>	\$ 399,943
<b>FOA Number</b>	DE-FOA-0002398
<b>Area of Interest</b>	Energy-Water Nexus Implications and Opportunities of a Hydrogen Economy

The objective of the project is to survey and document the current technologies that enable the integration of fossil fuels into the hydrogen economy with emphasis on tracking their potential for carbon neutrality and reduced water intensity. The project will develop tools to aid in planning and decision making including an adaptive evaluation platform to evaluate sensitivity of technology options to mitigate water consumption and to reduce cost and greenhouse gas emissions. A second tool developed under this project

will be a dynamic Sankey-like diagram to visualize hydrogen production, transport, storage, and use. The project also aims to involve and educate undergraduate and graduate students on the hydrogen economy.

The project will quantify the water demands associated with integration of hydrogen into the energy system, a critical step in enabling a transition to a hydrogen economy. Furthermore, the project will train a diverse group of engineering students on the challenges and benefits of hydrogen as a fuel.

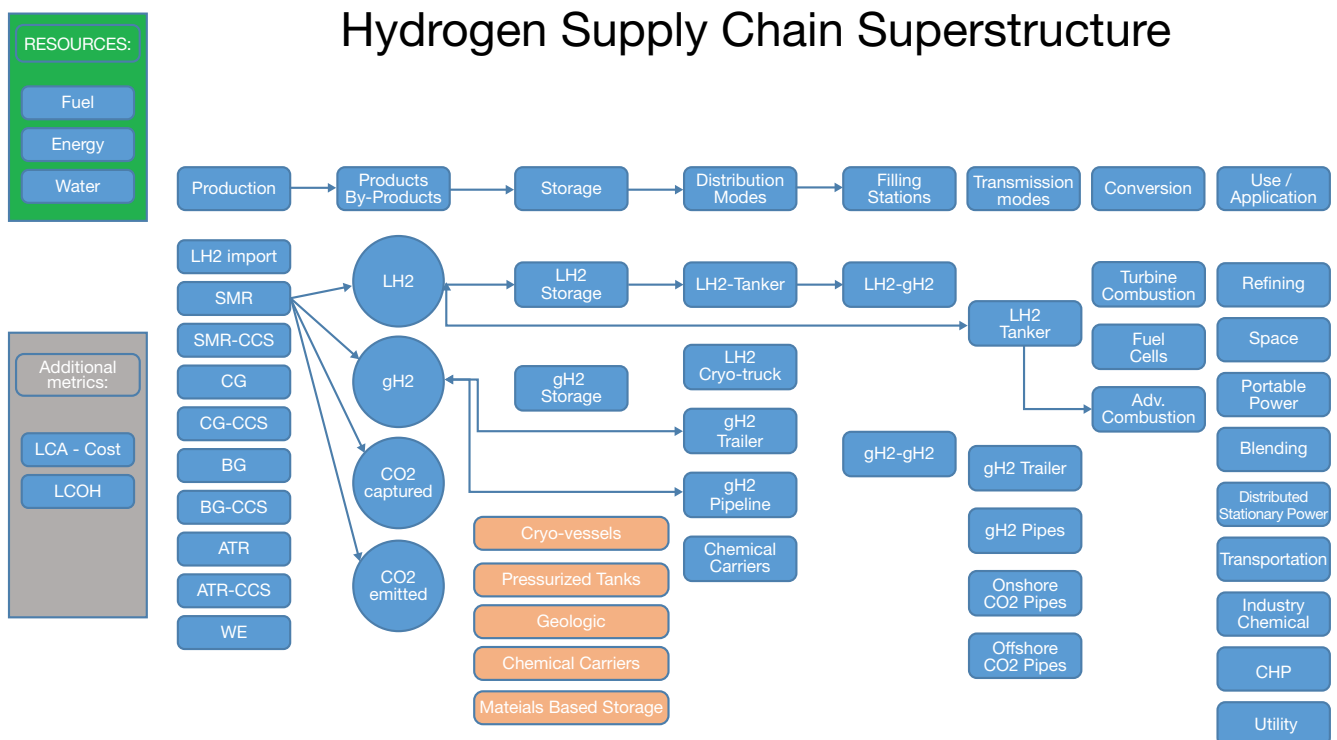

## UNIVERSITY CARBON RESEARCH PROGRAM

The UCR program emphasizes research and development efforts that are structured to achieve FECM strategic goals in concert with student education in relevant carbon management topics. Key research areas supported include (but are not limited to) near-zero-emission power plants, carbon capture, computational energy sciences, development of advanced high-performance materials, sensors and controls, and the development of hybrid power generation systems.

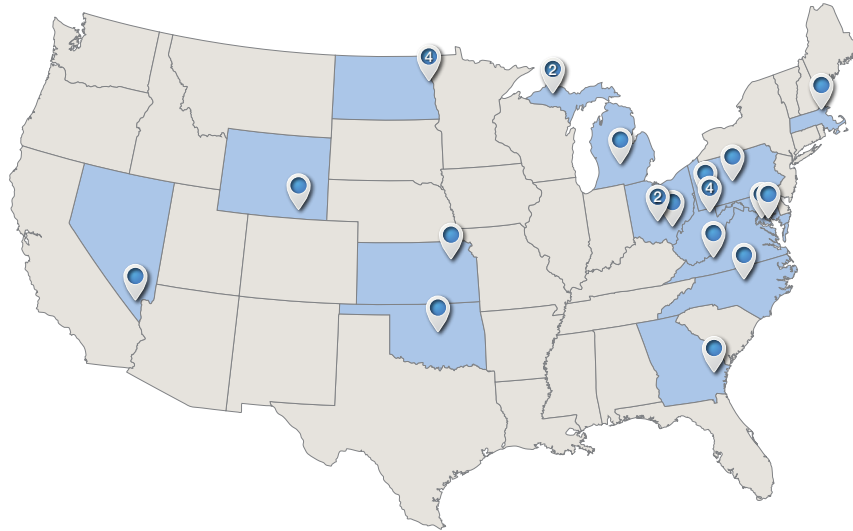

**UCR Participating Universities Location  
Active Projects as of October 1, 2023**

**Table 3: UCR Technologies—AOIS (Active Projects as of October 1, 2023)**

Key Technologies	Areas of Interest	# of Projects
Advanced Energy Materials	Electromagnetic Energy-Assisted Approaches to Convert Fossil Fuels to Low Cost Hydrogen	1
	Addressing High-Temperature Materials Supply Chain Challenges	2
	5G for Coal-Fired Power Generation	1
Coal Ash Analysis	Phytotechnology Development for Identification and/or Remediation of Sites Exhibiting Soil Contamination via Groundwater Transport of Metals from Coal Combustion Product Impoundments	2
	Resource Development Site Assessments to Inform Lifecycle Analysis/Techno-Economic Analysis	1
Existing Fleet Modeling	Techno-Economic Analysis and Lifecycle Analysis Screening of Net-Zero or Net-Negative Greenhouse Gas Emission, Carbon Capture and Storage-Enabled, Coal/Waste Coal and Biomass Power Production	1

<b>Key Technologies</b>	<b>Areas of Interest</b>	<b># of Projects</b>
Humanities-driven Science, Technology, Engineering and Mathematics	Humanities-driven science (including social science), technology, engineering and mathematics to enhance the FECM University Training Research Programs	1
Process Systems Engineering	Electromagnetic Energy-Assisted Approaches to Convert Fossil Fuels to Low Cost Hydrogen	1
	Techno-Economic Analysis and Lifecycle Analysis Screening of Net-Zero or Net-Negative Greenhouse Gas Emission, Carbon Capture and Storage-Enabled, Coal/Waste Coal and Biomass Power Production	2
	Value-Added Natural Gas Conversion	2
Sensors, Controls, and Other Novel Concepts	Automated Component Inspection, Analysis, and Repair Enabled by Robotics	2
	Cybersecure Sensors for Fossil Power Generation	1
	Application of Novel Analytical Method(s) to Determine Arsenic and/or Selenium Concentrations in Fly Ash Waste Streams Generated from Coal Combustion	1
	Novel Sensors and Controls for Flexible Generation	4
	5G for Coal-Fired Power Generation	1
Simulation-Based Engineering	Machine Learning for Computational Fluid Dynamics	1
	Process and Materials Co-Optimization for the Production of Blue Hydrogen	1
Solvents	Techno-Economic Analysis and Lifecycle Analysis Screening of Net-Zero or Net-Negative Greenhouse Gas Emission, Carbon Capture and Storage-Enabled, Coal/Waste Coal and Biomass Power Production	1

# UNIVERSITY CARBON RESEARCH (UCR)

<b>ADVANCED ENERGY MATERIALS.....</b>	<b>38</b>
<b>Michigan Technological University:</b> Hybrid Structured Nickel Superalloys to Address Price Volatility and Weld/Weld Repair Based Supply Chain Issues .....	38
<b>Ohio State University:</b> High-Speed and High-Quality Field Welding Repair Based on Advanced Non-Destructive Evaluation and Numerical Modeling .....	39
<b>University of North Dakota:</b> Electromagnetic Energy-Assisted Thermal Conversion of Fossil-Based Hydrocarbons to Low-Cost Hydrogen .....	40
<b>West Virginia University Research Corporation:</b> Conformal Coatings on Additive Manufactured Robust Alloys for Significant Mitigation of Oxidation, Erosion, and Corrosion .....	41
<b>COAL ASH ANALYSIS .....</b>	<b>42</b>
<b>University of Nevada, Reno:</b> Sustainable and Cost-Effective Phytoremediation Technologies in the Management of Contaminated Soils Adjacent to a Coal Combustion Product Impoundment .....	42
<b>Virginia Polytechnic Institute and State University:</b> A Data-Driven Multiscale Phytotechnology Framework for Identification and Remediation of Leached-Metals-Contaminated Soil Near Coal Ash Impoundments.....	43
<b>West Virginia University:</b> Integrated Life Cycle and Techno-Economic Assessments of Central Appalachian Legacy Mine Sites for Biomass Development and Waste Coal Utilization.....	44
<b>EXISTING FLEET MODELING .....</b>	<b>45</b>
<b>University of North Dakota:</b> Biogas Utilization in Refuse Power Plants (BURP2).....	45
<b>HUMANITIES-DRIVEN SCIENCE, TECHNOLOGY, ENGINEERING AND MATHEMATICS (HDSTEM) .....</b>	<b>46</b>
<b>Michigan Technical University:</b> Aluminum Critical Mineral Production via Landfill Mining: Environmental, Community, and Technical Feasibility for Integrated Multi-Material Resource Recovery .....	46
<b>PROCESS SYSTEMS ENGINEERING.....</b>	<b>47</b>
<b>Georgia Southern University Research and Service Foundation, Inc.:</b> Feasibility Study of Coal Refuse and Biomass/Torrefied Biomass Co-Fired Power Plant: Performance, Cost and Environmental Impacts .....	47
<b>Kansas State University:</b> Modular Reactor for Co-Generation of Liquid Chemicals and Electricity from Stranded Natural Gas.....	48
<b>Ohio State University:</b> Co-Firing Switchgrass and Waste Coal in a Power Plant: A Techno-Economic and Life Cycle Evaluation for the Ohio River Valley.....	49

<b>Pennsylvania State University:</b> Electric Field Assisted Thermo-Catalytic Decomposition: Comparisons with Reaxff Atomistic Simulations .....	50
<b>University of North Dakota:</b> Non-Catalytic Pyrolysis of Associated Gas to Zero-CO <sub>2</sub> Hydrogen and High Value Carbon Black.....	51
<b>SENSORS, CONTROLS, AND OTHER NOVEL CONCEPTS.....</b>	<b>52</b>
<b>Duke University:</b> Characterization of Arsenic and Selenium in Coal Fly Ash to Improve Evaluations for Disposal and Reuse Potential.....	52
<b>Michigan State University:</b> High-Accuracy and High-Stability Fiber-Optic Temperature Sensors for Coal Fired Advanced Energy Systems .....	53
<b>Ohio University:</b> Enabling the Next Generation of Smart Sensors in Coal Fired Power Plants Using Cellular 5G Technology.....	54
<b>Oklahoma State University:</b> Towards AI-Enabled Autonomy of Robotic Inspection Platforms for Sustainability of Energy Infrastructure .....	55
<b>University of Maryland:</b> Robust Heat-Flux Sensors for Coal-Fired Boiler Extreme Environments .....	56
<b>University of Massachusetts:</b> Wireless High Temperature Sensor Network for Boiler Systems .....	57
<b>University of North Dakota Energy and Environmental Research Center (UNDEERC):</b> Incorporating Blockchain/P2P Technology into an SDN-Enabled Cybersecurity System to Safeguard Fossil Fuel Power Generation Systems .....	58
<b>West Virginia University:</b> An Autonomous Robotic Inspection System for Coal Ash and Tailings Storage Facilities .....	59
<b>West Virginia University Research Corporation:</b> Passive Wireless Sensors for Realtime Temperature and Corrosion Monitoring of Coal Boiler Components Under Flexible Operation .....	60
<b>SIMULATION-BASED ENGINEERING .....</b>	<b>61</b>
<b>Carnegie Mellon University (CMU):</b> Advanced Modeling and Process-Materials Co-Optimization Strategies for Swing Adsorption Based Gas Separations.....	61
<b>Johns Hopkins University:</b> Developing Drag Models for Non-Spherical Particles through Machine Learning .....	62
<b>SOLVENTS .....</b>	<b>63</b>
<b>University of Wyoming:</b> Systems Analysis for Advancing Coal/Waste Coal-Biomass Co-Firing Power Plants with Deep Carbon Capture, Utilization and Storage Toward Net-Zero Emissions.....	63

# Hybrid Structured Nickel Superalloys to Address Price Volatility and Weld/Weld Repair Based Supply Chain Issues

<b>Performer</b>	Michigan Technological University
<b>Award Number</b>	FE0032071
<b>Project Duration</b>	09/03/2021 – 09/02/2024
<b>Total Project Value</b>	\$ 400,000
<b>FOA Number</b>	DE-FOA-0002398
<b>Area of Interest</b>	5G for Coal-Fired Power Generation

Two key factors affecting the fossil power high-temperature material supply chain are the volatility of nickel-based alloy prices and the challenges in welding precipitation-strengthened alloys. This project seeks to use integrated computational materials engineering (ICME) design strategies to solve these challenges by designing, casting, forging, welding, and validating the properties of hybrid eta-gamma prime-strengthened nickel superalloys optimized for cost and weldability. Specifically, significant reduction in cobalt to less than 5 wt% versus 10–20 wt% in candidate alloys for advanced energy systems is sought. Performance in high-temperature strength and creep will be maintained within 10 wt% compared against existing

candidate alloys designed for extreme environments. Weldability criteria will be evaluated through use of various susceptibility indices (solidification cracking, liquation, stress relief cracking) with the goal of broadening the welding and post-weld heat treat processing windows to be more forgiving.

Benefits are focused on providing alternatives to existing alloys with significant weldability issues which will enhance fabrication of new components, on-site assembly, and in-service repairs. Additional impacts include training graduate students in hybrid real-world/theoretical design methodologies to better prepare for advanced materials development.

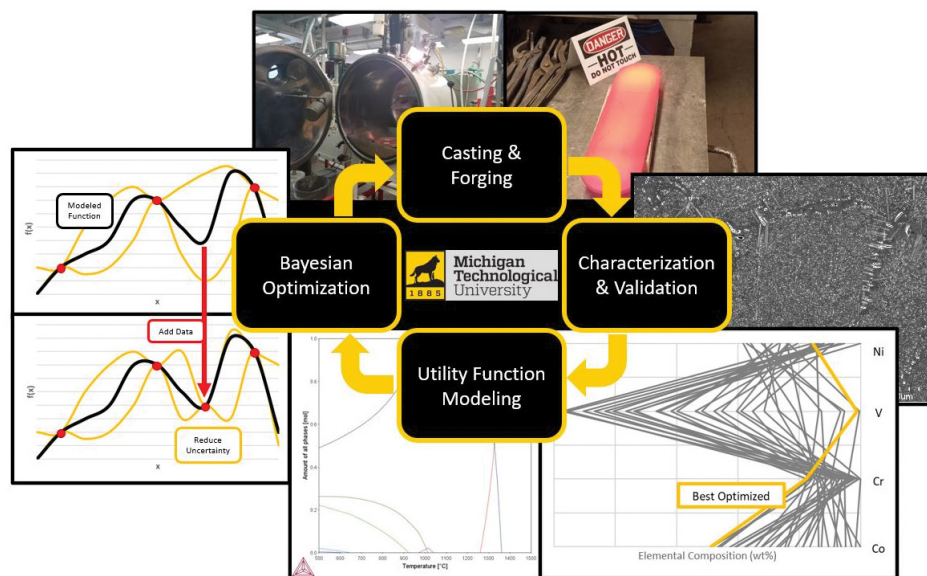

MTU Graphic.

## High-Speed and High-Quality Field Welding Repair Based on Advanced Non-Destructive Evaluation and Numerical Modeling

<b>Performer</b>	Ohio State University
<b>Award Number</b>	FE0032067
<b>Project Duration</b>	09/24/2021 – 09/23/2024
<b>Total Project Value</b>	\$ 400,000
<b>FOA Number</b>	DE-FOA-0002398
<b>Area of Interest</b>	Addressing High-Temperature Materials Supply Chain Challenges

The goal of the project is to establish the experimental and computational foundations that are crucial to implementation of high-speed and high-quality field welding repair based on advanced non-destructive evaluation (NDE) and numerical modeling. The scope of work of the project is focused on developing two enabling techniques for repair of CSEF grades 91 and 92 steel components: (1) microstructure detection using ultrasonic NDE, and (2) hardness prediction using a computational model for multi-pass, multi-layer welding.

Weld coupons will be fabricated using a high-deposition-rate process based on hot wire gas tungsten arc welding (GTAW). These weld coupons will be characterized for microstructure and hardness, which provides the baseline data for Gleeble® physical simulation to produce a bulk weld microstructure. Through the control of peak temperature and time, individual microstructures (especially martensite) with different levels of tempering will be produced. This simulated microstructure is needed since the actual weld comprises a highly inhomogeneous microstructure that is difficult for analysis by raw ultrasonics. Samples containing different microstructures will be scanned using ultrasonic

testing and advanced data processing algorithms such as machine learning will be used to find ultrasound parameters that are unique to the susceptible microstructures. The physics-based models will consider the heat transfer and molten pool fluid flow in a multi-pass, multi-layer dissimilar metal welding repair. The Gleeble testing results will also be used to develop a tempering kinetic model to predict the as-welded hardness distribution as well as that after post-weld heat treatment (PWHT).

High-quality field welding repairs on CSEF steel components are critical to the reliable and efficient operation of the current fleet of power plants in the United States. Development of a reliable field-usable NDE technique will ensure that the required microstructure is achieved after onsite welding. Additionally, establishing knowledge of weld reparability for newer CSEF steels such as Grade 92 based on advanced numerical models of welding processes will facilitate their adoption. The tools and knowledge to be generated in the project will establish experimental and computational foundations to achieve the overall goal of detecting and controlling microstructure and properties for welding repair onto CSEF steel components.

## Electromagnetic Energy-Assisted Thermal Conversion of Fossil-Based Hydrocarbons to Low-Cost Hydrogen

<b>Performer</b>	University of North Dakota
<b>Award Number</b>	FE0032061
<b>Project Duration</b>	08/01/2021 – 07/31/2024
<b>Total Project Value</b>	\$ 398,969
<b>FOA Number</b>	DE-FOA-0002398
<b>Area of Interest</b>	Electromagnetic Energy-Assisted Approaches to Convert Fossil Fuels to Low Cost Hydrogen

Hydrogen can be produced from the decomposition of hydrocarbons such as methane, without the production of carbon oxides. This represents a highly favorable route for hydrogen production compared to industrial production methods based predominantly on steam-methane reforming (SMR). Breaking hydrogen-oxygen bonds in water requires about seven times the energy compared to breaking carbon-hydrogen bonds in methane. SMR and methane decomposition processes both require indirect heating to provide the overall endothermic heat of reaction for hydrogen formation, but the heat of reaction for the SMR is more than double that for methane decomposition. In contrast to the SMR process, the methane decomposition process offers a promising path for economical and environmentally sound production of hydrogen without production of carbon dioxide.

The goal of this project is to make targeted improvements to the conventional thermo-catalytic hydrocarbon conversion process using an electromagnetic energy assisted mechanism; resulting in the reduction of downtime associated with catalyst reactivation or replacement due to poisoning. State-of-the-art solid catalysts exhibit short process lifetimes that are not suitable for commercial application. This project uses both experimental and computational tools to understand the fundamental

interactions between fossil fuels and their interactions with an electromagnetic energy source. This technology can utilize natural gas or volatiles obtained from coal decomposition to provide carbon dioxide-free hydrogen. The first objective of this project is to identify catalyst supports that enhance the electromagnetic energy-assisted mechanism to ensure in-situ catalyst reactivation to near-initial fresh conditions. The performance of these prepared catalysts will be tested in laboratory units and the results will be used to validate computational fluid dynamics (CFD) and chemical kinetics models. Finally, CFD will be used to investigate the electromagnetic energy-assisted conversion mechanism as a function of catalyst structure and operating conditions for hydrogen production.

This study will provide future researchers with a cost-effective tool to explore a multitude of yet-to-be-conceived electromagnetic systems to ensure long-term catalytic activity. The proposed technology has the potential to extend the longevity of catalyst materials, thereby reducing overall catalyst replenishment costs. With these improvements to the conventional thermo-catalytic hydrocarbon conversion process, it is hoped to enable a wider adoption of hydrogen-related technologies from fossil resources. This project will also support two graduate students focused on fossil energy research.



## Conformal Coatings on Additive Manufactured Robust Alloys for Significant Mitigation of Oxidation, Erosion, and Corrosion

<b>Performer</b>	West Virginia University Research Corporation
<b>Award Number</b>	FE0032068
<b>Project Duration</b>	09/15/2021 – 09/14/2024
<b>Total Project Value</b>	\$ 400,000
<b>FOA Number</b>	DE-FOA-0002398
<b>Area of Interest</b>	Addressing High-Temperature Materials Supply Chain Challenges

The project aims to develop novel high-temperature alloys from Ni-based alloys that further integrate additive manufacturing (AM) fabrication, creating novel nanoscale oxide precipitation for strengthened mechanical integrity and enhanced oxidation resistance, and subsequent application of conformal protective coatings on the additive-manufactured alloys. To increase the strength and oxidation resistance of nickel alloys, erbium and titanium oxide ( $\text{Er}_2\text{O}_3$  and  $\text{TiO}$ ) precipitants will be added to the AM powders for the Inconel 625 alloy and will result in dense nano-oxide precipitation of  $\text{Er}_2\text{O}_3$  and  $\text{Er}_2\text{Ti}_2\text{O}_7$ , which will result in a solution-strengthened novel Ni-based alloy. Furthermore, a conformal protective oxide coating layer will be simultaneously applied on both the internal and external surface of the additive manufactured heat exchangers with complex geometry using atomic layer deposition (ALD). The ALD layer will be conformal, uniform, pin-hole free, dense, and ultra-thin with negligible weight gain to increase both the oxidation and corrosion resistance at elevated temperatures.

The project is organized into five tasks. Task 1 is project management. Task 2 is devoted to introducing the dense

precipitates into the Ni-based alloys through AM. Task 3 is devoted to ALD coating of the newly additive manufactured 3D printed Ni-based alloys and ALD repairing and recoating the alloys after oxidation exposure. Task 4 is the oxidation resistance testing of the additive manufactured and ALD coated Ni-based alloys. Task 5 is the comprehensive physical properties testing and nanostructure analysis of the additive manufactured alloys (including those with precipitates), ALD coated alloys, and the alloys after exposure to the oxidation and corrosion environments.

The developed high-temperature materials are expected to possess superior strength, high resistance to external surface oxidation, internal surface carburization, and corrosion, and can be applied to heat exchangers for operation in supercritical carbon dioxide at high temperatures (over 750 °C) and pressure (30 MPa). For after-service heat exchangers that have damaged surfaces, the proposed ALD coating can also be utilized to repair/refurbish the heat exchanger parts that may have been impacted by surface oxidation and dramatically increase their lifetime and reduce costs.

## Sustainable and Cost-Effective Phytoremediation Technologies in the Management of Contaminated Soils Adjacent to a Coal Combustion Product Impoundment

<b>Performer</b>	University of Nevada, Reno
<b>Award Number</b>	FE0032195
<b>Project Duration</b>	03/06/2023 – 03/05/2026
<b>Total Project Value</b>	\$ 396,835
<b>FOA Number</b>	DE-FOA-0002596
<b>Area of Interest</b>	Phytotechnology Development for Identification and/or Remediation of Sites Exhibiting Soil Contamination via Groundwater Transport of Metals from Coal Combustion Product Impoundments

The goal of this project is to mitigate the environmental burdens associated with coal combustion products ponds at the North Valmy power plant by finding native plants and establishing a vegetation cover to (Phyto)extract the toxic heavy metals from the ponds and (Phyto)stabilize the (ultra)fine particles of residues. The project goal will be achieved by developing low-cost methods that will indicate whether a storage facility is keeping contaminants within its storage boundary and advancing environmentally friendly technologies that can remediate affected sites.

If successful, this project could provide a low-cost, easy-

to-use, and permanent opportunity for the identification of polluted sites through the application of plant species known as bioindicators and could result in significant remediation of the affected sites. There is growing evidence that some plant species such as *Lygeum spartum*, *Atractylis serratuloides*, and *Gymnocarpus decander* arise as potential bioindicators/biosensors of heavy metals pollution highly beneficial to indirectly monitoring the contaminated areas. Lastly, bioindicator species could be used for monitoring pollution through newly developed technologies such as remote sensing, machine learning, or artificial intelligence.

# A Data-Driven Multiscale Phytotechnology Framework for Identification and Remediation of Leached-Metals-Contaminated Soil Near Coal Ash Impoundments

<b>Performer</b>	Virginia Polytechnic Institute and State University
<b>Award Number</b>	FE0032184
<b>Project Duration</b>	10/01/2022 – 09/30/2025
<b>Total Project Value</b>	\$ 400,000
<b>FOA Number</b>	DE-FOA-0002596
<b>Area of Interest</b>	Phytotechnology Development for Identification and/or Remediation of Sites Exhibiting Soil Contamination via Groundwater Transport of Metals from Coal Combustion Product Impoundments

The project objectives are to integrate satellite remote sensing, machine learning and image processing, geological engineering models, and soil science and plant pathology to (1) identify potential leaching of metals from coal ash impoundments (Phase I), and (2) propose locally adaptable phytoextraction approaches to remediate contaminated regions (Phase II). The analyses will consider potentially contaminated areas surrounding coal combustion product impoundments of southern West Virginia, south-west Virginia, eastern Kentucky, eastern Tennessee, and North Carolina. The project will develop a locally adapted phytoremediation

design including a database of phytoremediation potential of different hyperaccumulating plants, an environmental justice screening to prioritize areas with high environmental justice impact, and a machine-learning-informed model that outputs a ranked list of suggested plant species for each candidate site.

The project aims to advance the application of phytoremediation to coal ash impoundments and could lead to low-cost identification of heavy metal contamination and subsequent remediation at legacy waste sites.

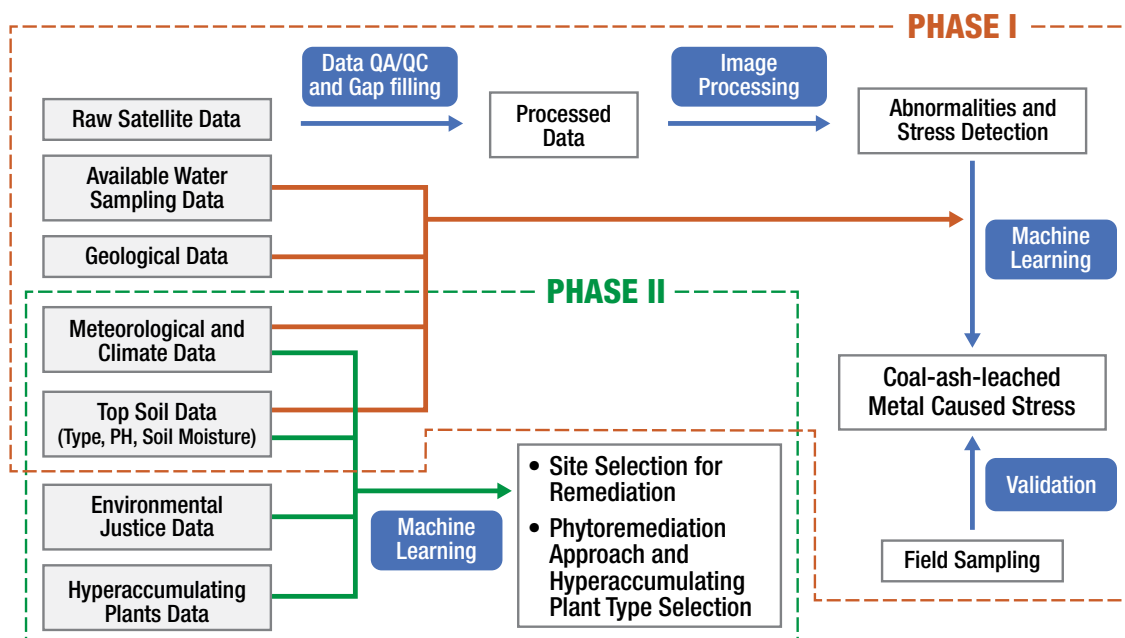

Project Plans.

## Integrated Life Cycle and Techno-Economic Assessments of Central Appalachian Legacy Mine Sites for Biomass Development and Waste Coal Utilization

<b>Performer</b>	West Virginia University
<b>Award Number</b>	FE0032212
<b>Project Duration</b>	10/01/2022 – 09/30/2024
<b>Total Project Value</b>	\$ 400,000
<b>FOA Number</b>	DE-FOA-0002596
<b>Area of Interest</b>	Resource Development Site Assessments to Inform Lifecycle Analysis/ Techno-Economic Analysis

The specific objectives of this proposed project are to (1) characterize legacy sites, remediation and resource extraction to assess coal refuse sites with the assistance of machine learning (ML) models, and develop legacy mine site reclamation strategies for biomass development with best management practices; and (2) conduct integrated ML-based life cycle and techno-economic assessments

to quantify the environmental and economic benefits of biomass cultivation on the reclaimed mine lands, and evaluate the major feasible and effective engineering pathways for biomass-waste coal utilizations. If successful, this project will help to mitigate greenhouse gas emission, improve the local environment, and facilitate rural economic development.

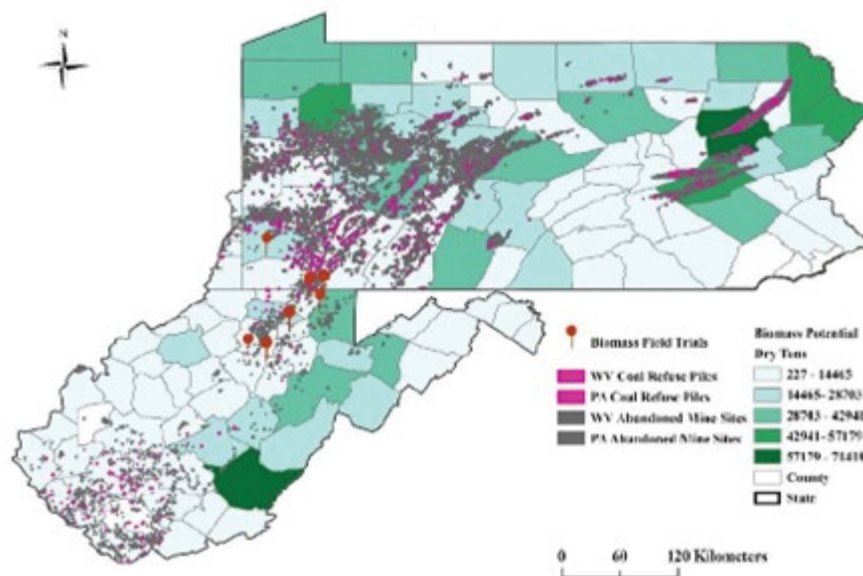

Legacy mine sites, coal refuse piles, and forest biomass.

## Biogas Utilization in Refuse Power Plants (BURP2)

<b>Performer</b>	University of North Dakota
<b>Award Number</b>	FE0032194
<b>Project Duration</b>	10/01/2022 – 09/30/2024
<b>Total Project Value</b>	\$ 400,000
<b>FOA Number</b>	DE-FOA-0002596
<b>Area of Interest</b>	Techno-Economic Analysis and Lifecycle Analysis Screening of Net-Zero or Net-Negative Greenhouse Gas Emission, Carbon Capture and Storage-Enabled, Coal/Waste Coal and Biomass Power Production

The University of North Dakota (UND) will use the first six months to assess the retrofit repowering options at three existing waste-coal-fired plant locations in Pennsylvania and West Virginia. The purpose of this initial investigation is to provide a quick-reference tool to size different units depending on the feedstock availability and composition. Subsequently, UND will complete two techno-economic analyses, one for a retrofitted waste coal power plant facility

and another for a greenfield waste coal facility. Each of these facilities will include a carbon capture system. A life cycle analysis will be conducted jointly with the other tasks to help guide decision making regarding feedstock composition, plant logistics, and critical carbon-related cradle-to-grave considerations.

This project will help develop technology that can use waste material to produce power with low or no carbon emissions.

# Aluminum Critical Mineral Production via Landfill Mining: Environmental, Community, and Technical Feasibility for Integrated Multi-Material Resource Recovery

<b>Performer</b>	Michigan Technical University
<b>Award Number</b>	FE0032236
<b>Project Duration</b>	04/01/2023 – 03/31/2026
<b>Total Project Value</b>	\$ 749,980
<b>FOA Number</b>	DE-FOA-0002596
<b>Area of Interest</b>	Humanities-driven science (including social science), technology, engineering and mathematics to enhance the FECM University Training Research Programs

The overall project objective is to develop a process to assess landfill contents and design a process to extract and separate aluminum. Social science analysis of the landfill history and surrounding community will be key to selecting a landfill pilot with a high probability of being viable economically, environmentally, and within the community. Environmental impacts will be identified and quantified for the prospective landfill sites. Separation techniques will be evaluated and a pilot-scale test apparatus for aluminum separation will be built. Finally, the details of aluminum recovery will be developed to optimize recovered aluminum quality by casting high quality ingots for characterization.

Aluminum is designated as a critical mineral and is used in such applications as air and ground vehicles, packaging, and electrical. However, no commercially viable mining of bauxite for aluminum production occurs in the United States and the greatest U.S. concentration of high-grade aluminum feedstock is in landfills. Recovering and recycling this aluminum would reduce U.S. dependence on imported bauxite for aluminum production, reduce energy and greenhouse gas emissions associated with aluminum production, reclaim landfill materials, and reduce landfill volume.



Project Plan.

## Feasibility Study of Coal Refuse and Biomass/Torrefied Biomass Co-Fired Power Plant: Performance, Cost and Environmental Impacts

<b>Performer</b>	Georgia Southern University Research and Service Foundation, Inc.
<b>Award Number</b>	FE0032185
<b>Project Duration</b>	10/01/2022 – 09/30/2024
<b>Total Project Value</b>	\$ 399,920
<b>FOA Number</b>	DE-FOA-0002596
<b>Area of Interest</b>	Techno-Economic Analysis and Lifecycle Analysis Screening of Net-Zero or Net-Negative Greenhouse Gas Emission, Carbon Capture and Storage-Enabled, Coal/Waste Coal and Biomass Power Production

The primary project goal is to identify optimal biomass/torrefied biomass and coal refuse cofiring ratios to produce carbon-neutral or carbon-negative power generation from co-fired power plants. Specific goals are to develop a techno-economic analysis (TEA) and life cycle analysis (LCA) of a biomass/torrefied biomass and coal refuse co-fired power plant. Objectives are to examine heat and mass balances for coal refuse and biomass cofiring scenarios; evaluate levelized cost of electricity (LCOE); assess environmental impacts, including greenhouse gas emissions; and identify the effects of torrefaction and pelleting on the performance, cost, and environmental impacts of various cofiring ratios. The team will produce novel data on this method to achieve carbon-neutral or carbon-negative power generation using coal refuse and low-carbon biomass/torrefied biomass.

The data outcomes of this project will produce these benefits:

1. Optimal process conditions to produce carbon-neutral or carbon-negative power generation from coal refuse and biomass/torrefied biomass co-fired power plants, significantly reducing CO<sub>2</sub> and other environmental emissions and consequently improving the global climate, economy, energy independence, and job creation.
2. Determination of the effects of plant capacity, plant efficiency, cofiring ratios, cost of feedstock, and carbon capture levels on LCOE.
3. Education and training of postdoctoral, graduate, and undergraduate students to develop a diverse workforce to mitigate climate change.

## Modular Reactor for Co-Generation of Liquid Chemicals and Electricity from Stranded Natural Gas

<b>Performer</b>	Kansas State University
<b>Award Number</b>	FE0032235
<b>Project Duration</b>	06/01/2023 – 05/31/2026
<b>Total Project Value</b>	\$ 500,000
<b>FOA Number</b>	DE-FOA-0002596
<b>Area of Interest</b>	Value-Added Natural Gas Conversion

This project will work to design, demonstrate, and test a novel process-intensified modular system with techno-economic feasibility which integrates an electrocatalyst with electrochemical membrane reactors for natural gas (NG) upgrading to value-added liquid chemicals (aromatics) and power generation simultaneously. Different aspects of the design have already been tested and validated under various operating conditions. The NG conversion and aromatics yield can be significantly improved through the enhanced reaction kinetics by electrochemically utilizing the hydrogen product for electricity generation. The proposed

modular system aims to achieve NG conversion of >30%, aromatics yield of >50% increase, and >90% reduction in CO<sub>2</sub> emissions.

The modular systems will be deployed to use stranded NG, while providing power for oil and gas facilities, which fosters wide deployment of modular systems for onsite NG conversion. The project will educate and train the next generation of engineers and scientists, support early-stage research innovations, and equip the students with cutting-edge, translatable skillsets to succeed in enduring careers.

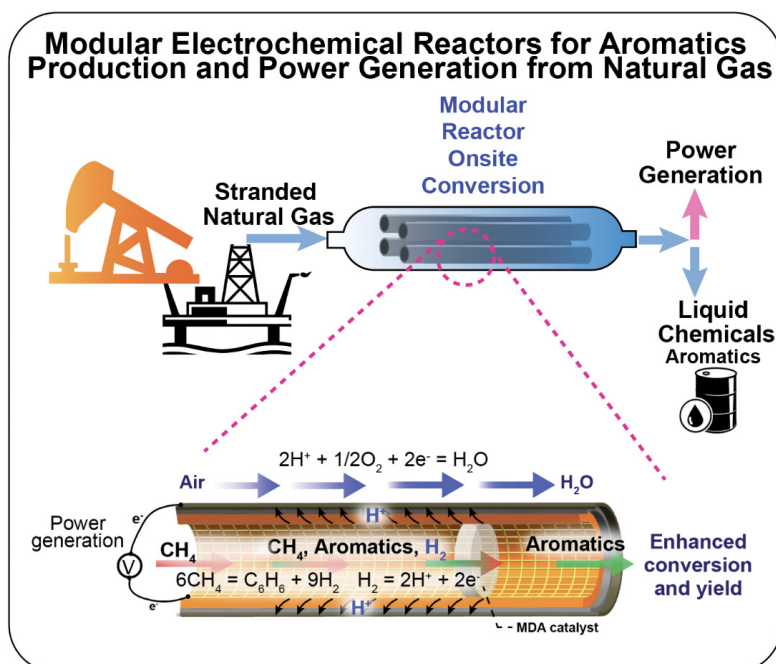

Project Schematic.



# Co-Firing Switchgrass and Waste Coal in a Power Plant: A Techno-Economic and Life Cycle Evaluation for the Ohio River Valley

<b>Performer</b>	Ohio State University
<b>Award Number</b>	FE0032204
<b>Project Duration</b>	10/01/2022 – 09/30/2024
<b>Total Project Value</b>	\$ 399,869
<b>FOA Number</b>	DE-FOA-0002596
<b>Area of Interest</b>	Techno-Economic Analysis (TEA) and Lifecycle Analysis (LCA) Screening of Net-Zero or Net-Negative, CCS-Enabled, Coal/Waste Coal and Biomass Power Production

The overall objective of this project is to develop a modeling framework and identify the scenarios with net-zero or net-negative greenhouse gas (GHG) emissions and lower levelized cost of energy production (LCOE) for a waste coal and switchgrass co-fired power plant equipped with carbon

capture and storage (CCS) in the Ohio River Valley.

A set of modeling tools will be developed for analyzing the GHG and LCOE of power plants burning waste coal and switchgrass that are also equipped with CCS technology.

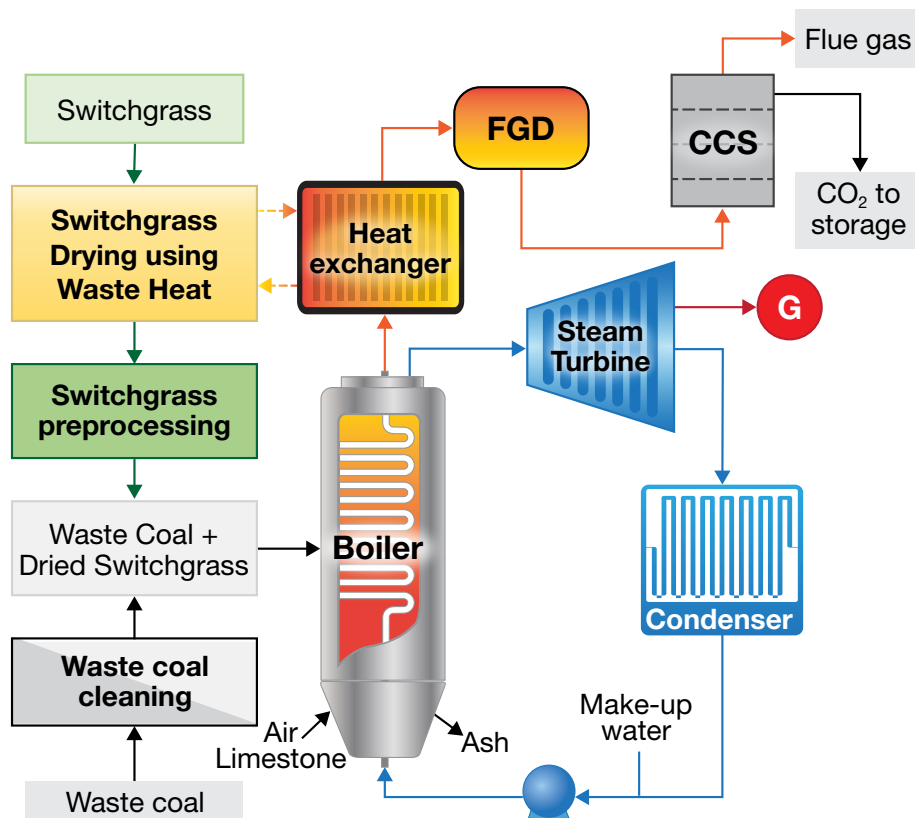

Flow diagram.

## Electric Field Assisted Thermo-Catalytic Decomposition: Comparisons with Reaxff Atomistic Simulations

<b>Performer</b>	Pennsylvania State University
<b>Award Number</b>	FE0032070
<b>Project Duration</b>	08/01/2021 – 07/31/2024
<b>Total Project Value</b>	\$ 399,435
<b>FOA Number</b>	DE-FOA-0002398
<b>Area of Interest</b>	Electromagnetic Energy-Assisted Approaches to Convert Fossil Fuels to Low Cost Hydrogen

Thermo-catalytic decomposition (TCD) is an alternative energy technology to produce (blue) hydrogen by decarbonizing fossil fuels, providing a bridge to the hydrogen economy. A limitation is the ongoing deactivation of the carbon catalyst as deposited carbon from the decomposition reaction reduces the number of catalyst active sites. Cyclic regeneration complements the TCD reaction by creating new active sites through partial oxidation by  $\text{CO}_2$ , renewing carbon catalyst activity. Moreover, partial gasification of deposited carbon by  $\text{H}_2\text{O}$  (generating  $\text{H}_2$ , the desired end product) also regenerates the catalyst. This establishes applicability of electric (E)-field enhancement to a coal feed and serves as a baseline for gasification of coal. Neither TCD nor carbon oxidation has been tested under an E-field for change in activation energy or mechanism. For both reactions, an imposed electric field may maintain and potentially increase the reaction rate, either by an increase in active site number or a shift in component energy level and the associated activation energy for reactions.

It is hypothesized that an applied E-field changes the reaction mechanism. This project will test two field configurations, perpendicular imposing only voltage stress and parallel imposing current stress. Active site and kinetic dependence upon reactive gases and their concentrations will be mapped parametrically as a function of applied E-field strength, polarity, direction, and frequency. Changes in rates may be resolved by active site number or activation energy. ReaxFF (reaction force field)-based molecular dynamics simulations will be compared to experimental measurements of activation energy and kinetics of deposition to test the hypothesis that the E-field changes the reaction mechanism, manifested by activation energy and kinetics of deposition, for both TCD and regeneration reactions.

A steady or increased catalytic rate produced by an applied E-field removes a critical barrier to TCD implementation at scale and its potential to negate regeneration. Similarly, gains in gasification rates and their origin(s) under an applied E-field will be probed. Improved regeneration rates can benefit CO production for syngas or  $\text{H}_2$  production by gasification of feedstocks such as coal with greater energy efficiency and reduced  $\text{CO}_2$  footprint. Measurement of active sites and predictions by atomistic simulations will provide mechanistic insights for carbon surface reactions relevant to both TCD and regeneration reactions, addressing the mechanism of E-field enhancement for carbon surface reactions for  $\text{H}_2$  generation from fossil fuels.

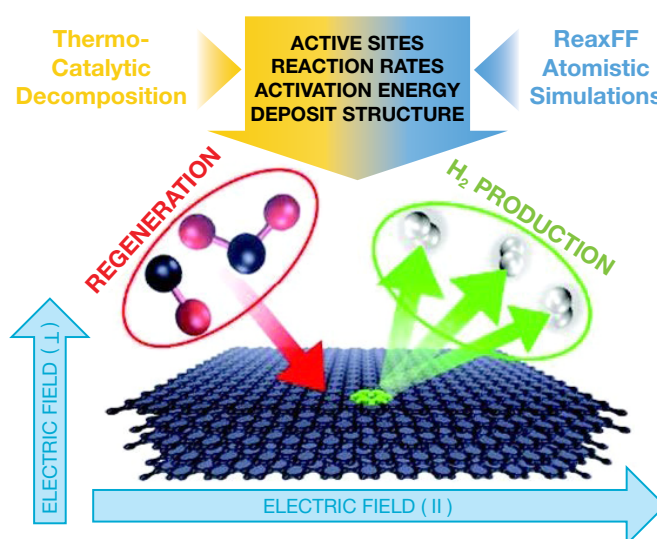

Combined experiment plus modeling for E-field enhanced thermo-catalytic decomposition of methane for hydrogen production.

## Non-Catalytic Pyrolysis of Associated Gas to Zero-CO<sub>2</sub> Hydrogen and High Value Carbon Black

<b>Performer</b>	University of North Dakota
<b>Award Number</b>	FE0032234
<b>Project Duration</b>	05/01/2023 – 04/30/2025
<b>Total Project Value</b>	\$ 500,000
<b>FOA Number</b>	DE-FOA-0002596
<b>Area of Interest</b>	Value-Added Natural Gas Conversion

This project will perform an engineering design and economic analysis study of the conversion of associated gas in the Bakken to high-value carbon black and hydrogen using the Microwave Plasma Pyrolysis (MPP) process developed by H Quest Vanguard, Inc (HQV). A multi-well pad producing oil and associated gas in the Bakken/Three Forks shale play will be selected as the basis of the design study.

The MPP process is a proprietary, novel, modular and energy efficient chemical conversion technology enabled by microwave plasma. The scalable microwave plasma reactor concept enables rapid, continuous, direct (single-step) conversion of methane and higher hydrocarbons to hydrogen and high-value carbons, with control over product selectivity, across a wide range of feed compositions and energy inputs.

The project will combine experimental testing, process

modeling, economic and environmental analysis to significantly de-risk the economics of deploying the MPP process at well pads within the Bakken region by quantifying the financial and economic benefits of the process for a representative well site operator or owner.

The anticipated public benefits of the project are far reaching and go beyond the value-added elimination of wasteful and environmentally harmful flaring. Displacement of conventional carbon blacks with the sustainable pyrolysis analogues can reduce the global emission of 40–60 million tons of CO<sub>2</sub>/year. Other emerging uses of the sustainable carbon target are new large-scale infrastructure and energy storage applications. The project will also provide future researchers with valuable skillsets needed to integrate a low-carbon economy resource by focusing on the interconnection between technical performance and economic viability.

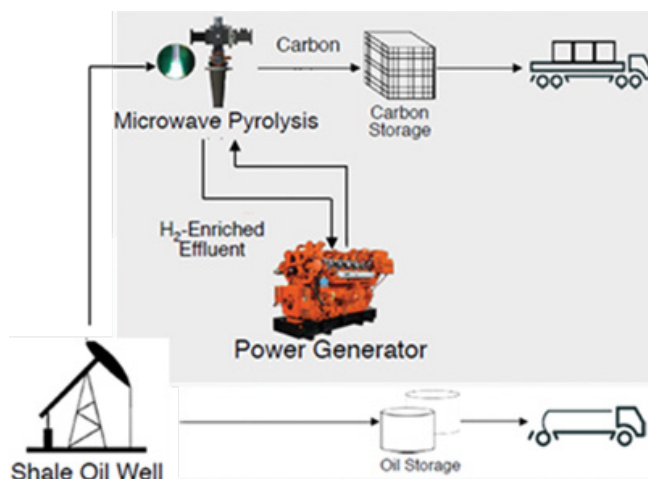

Project Schematic.

## Characterization of Arsenic and Selenium in Coal Fly Ash to Improve Evaluations for Disposal and Reuse Potential

<b>Performer</b>	Duke University
<b>Award Number</b>	FE0031748
<b>Project Duration</b>	09/01/2019 – 05/31/2024
<b>Total Project Value</b>	\$ 400,000
<b>FOA Number</b>	DE-FOA-0001991
<b>Area of Interest</b>	Application of Novel Analytical Method(s) to Determine Arsenic and/or Selenium Concentrations in Fly Ash Waste Streams Generated from Coal Combustion

This project aims to establish high-throughput characterization methods for arsenic (As) and selenium (Se) species in coal fly ash and understand how coal combustion parameters might influence leachable As and Se contents from fly ash. Specifically, the project will (1) compare methods for determining As and Se concentration, chemical speciation, and mass distribution in fly ash and establish the efficacy of these methods taking into account data quality and operator accessibility, (2) evaluate As, Se, and fly ash characteristics and measurement methods that can improve indications of leachability and mobilization potential from fly ash, and (3) perform a survey of As and Se characterization for fly ashes representing a variety of coal feedstocks, combustion conditions, and emissions controls. Duke University will study methods to quantify the chemical forms of As and Se by comparing a series of state-of-the-art quantitative methods (e.g., synchrotron-based X-ray spectroscopy and microscopy) with alternative ‘benchtop’ spectroscopy methods that are commonly employed in the materials and geological sciences.

The evaluation will consider benefits and trade-offs of each method, including quantitative versus qualitative determination, throughput capacity, and ease of sample processing. These characterization techniques will be compared to As and Se mobilization potential from fly ash as indicated by waste leaching protocols established by waste disposal regulations. These evaluations of As and Se concentration, speciation, mass distribution, and mobilization potential will be applied to a large variety of coal fly ashes that represent a range of coal sources, boiler types, ash collection systems, emissions controls, and combustion conditions.

Results obtained from this work will enable practitioners to understand data generated from qualitative methods that may be more accessible than state-of-the-art synchrotron techniques. A comprehensive database of As and Se speciation in a variety of coal fly ashes and other residuals will be generated. The study will outline advantages and tradeoffs for each method and establish correlations to leaching potential.

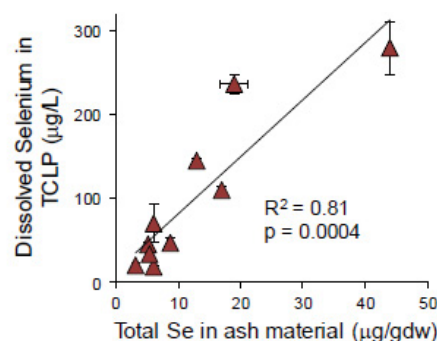
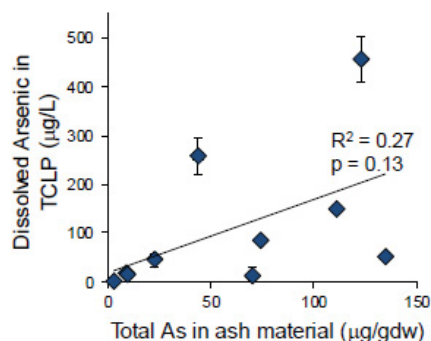

Leachable As and Se from 10 coal ash samples subjected to the toxicity characteristic leaching procedure. Data from Schwartz et al. 2018

## High-Accuracy and High-Stability Fiber-Optic Temperature Sensors for Coal Fired Advanced Energy Systems

<b>Performer</b>	Michigan State University
<b>Award Number</b>	FE0031899
<b>Project Duration</b>	09/01/2020 – 08/31/2024
<b>Total Project Value</b>	\$ 496,475
<b>FOA Number</b>	DE-FOA-0002193
<b>Area of Interest</b>	Novel Sensors and Controls for Flexible Generation

The objective of this project is to develop a revolutionary gas-based fiber-optic temperature sensor technology with the required accuracy and long-term stability for temperature control and condition monitoring of next-generation of coal-fired power systems. The temperature sensor technology is based on a Fabry-Perot (FP) cavity filled with a gas (e.g., air) the pressure of which can be changed. An FP cavity is formed by a silica tube that is filled with air and sandwiched between a side-hole fiber and a capping fiber. The holey fiber has air channels in its cladding running along the length of the fiber through which the air pressure in the FP cavity can be tuned. The light coming from the holey fiber is partially reflected at the two fiber/tube interfaces and coupled back into the holey fiber. The system then measures the reflection spectrum which contains the interference fringes of the FP cavity by a white-light source, a fiber-optic coupler, and a spectrometer.

Accurately controlling the temperature is critical for the reliable and efficient operation of future highly efficient coal-fired energy systems. An accurate temperature sensor with long-term operating reliability is key for temperature control. Temperature is also a critical parameter for condition monitoring and lifetime prediction of energy systems. However, the extreme conditions present in advanced energy systems often lead to accelerated degradation in the performance and lifetime of current sensors. Most sensors used today show unacceptable drift and require frequent calibration or replacement, often leading to costly power plant shut down. The movement toward advanced energy systems requires that new temperature sensors be developed which can maintain accuracy and long-term stability comparable to or better than low-temperature sensors over extended periods of operation under extreme conditions.

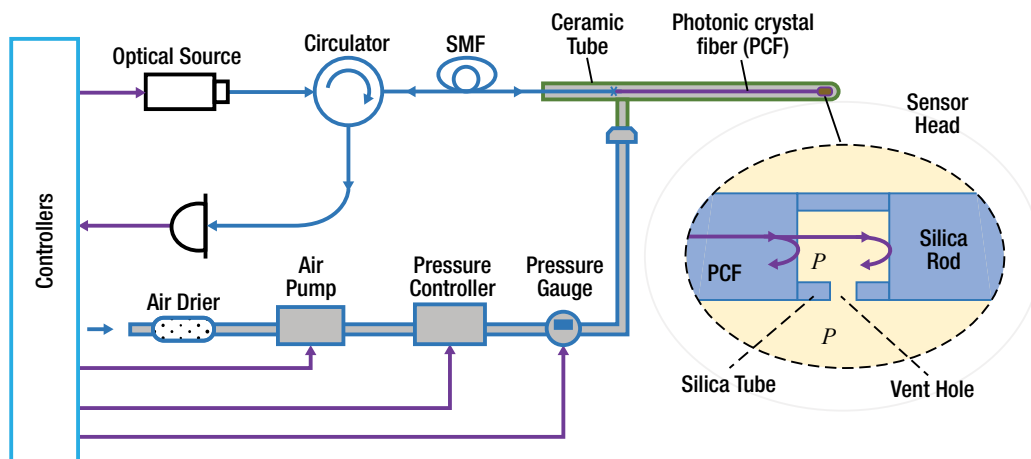

Temperature sensor system that can operate at a temperature level above 1000 °C with accuracy and long-term stability comparable to the sensors of low-temperature version.

## Enabling the Next Generation of Smart Sensors in Coal Fired Power Plants Using Cellular 5G Technology

<b>Performer</b>	Ohio University
<b>Award Number</b>	FE0032078
<b>Project Duration</b>	08/16/2021 – 08/15/2024
<b>Total Project Value</b>	\$ 414,481
<b>FOA Number</b>	DE-FOA-0002398
<b>Area of Interest</b>	5G for Coal-Fired Power Generation

This project will build upon existing experience with cellular-based systems, power plant water quality sensing, and high-temperature sensors developed during past projects. The main objective of this project is to demonstrate the effectiveness of 5G cellular embedded, cloud, and edge computing-based sensors specific to coal-fired power plant needs where harsh, noisy radio frequency (RF) conditions are encountered. Sensors that utilize 5G for data communications are the first logical step in revolutionizing wireless connectivity that will enable robust operations in coal-fired power plants. Working together, Ohio University and West Virginia University will focus on a high-priority in-situ boiler temperature measurement system that relies on chipless radio-frequency identification (RFID) technology and much-needed temperature, pressure, environmental, and water quality industrial sensors.

The specific project objectives are to (1) investigate specific needs of interfacing and data collection of identified sensing areas of significance within coal-fired power plants that would immediately benefit from 5G wireless data communications, (2) enable 5G data communication for ‘peel-and-stick’ chipless RFID-based boiler temperature and corrosion sensors, (3) demonstrate effectiveness and performance of 5G enabled internet-of-things (IoT) sensors used in coal-fired power plants, (4) investigate sensor-driven deep learning/artificial intelligence using laboratory conditions that simulate power plants for system health monitoring, and (5) determine the limits of 5G systems in harsh environments—hot, humid, and cold.

The duty cycle style of power plant operation combined with a need to lower operating costs has left several components

of coal-fired power plants vulnerable to unscheduled maintenance. More advanced, intelligent, inexpensive, and simple-to-install monitoring equipment based on wireless data transfers will support the current and future coal power plant needs. Coal power plant operators could greatly benefit from retrofitting of existing sensors and additional sensor and control systems throughout. In addition, the intelligent health monitoring capabilities that occur at the sensor (embedded computing) or base station (edge computing) will give operators more prediction tools about scheduling maintenance.

Graduate students at both universities will be employed and trained on our respective technologies and will cross-collaborate to exchange information and gather laboratory results.

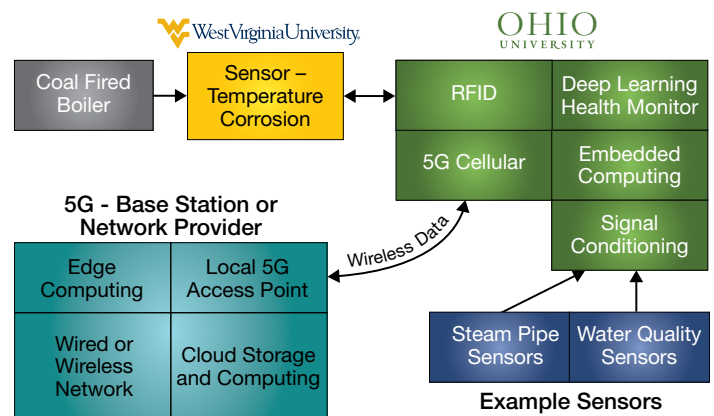

Proposed system integration – identifying contributions.

## Towards AI-Enabled Autonomy of Robotic Inspection Platforms for Sustainability of Energy Infrastructure

<b>Performer</b>	Oklahoma State University
<b>Award Number</b>	FE0032196
<b>Project Duration</b>	02/01/2023 – 01/31/2026
<b>Total Project Value</b>	\$ 500,000
<b>FOA Number</b>	DE-FOA-0002596
<b>Area of Interest</b>	Automated Component Inspection, Analysis, and Repair Enabled by Robotics

The research objective of this project is to develop an integrated AI-driven robotic visual inspection (RVI) platform with autonomous dynamic path planning and safe navigation capability for closed-loop data collection and real-time defect identification. The key motivator of this research is to integrate deep-learning defect identification models for dynamic and safe path and motion planning in real time using multimodal data. To achieve the overall objective, the project is divided into two phases, Phase I for 24 months and Phase II for 12 months. In Phase I, the team will develop (1) deep neural networks for low-light image/video

enhancement, (2) multimodal and meta-learning for defect classification, and (3) safe and dynamic path and motion planning for autonomous navigation. In Phase II researchers will focus on (4) implementation and experimental validation of the developed technology through robotics simulator and RVI hardware platforms.

This project could increase the level of autonomy of RVI platforms, while contributing to sustainability of the energy sector. Success could lead to TRL 5 or higher by the end of the project.

## Robust Heat-Flux Sensors for Coal-Fired Boiler Extreme Environments

<b>Performer</b>	University of Maryland
<b>Award Number</b>	FE0031902
<b>Project Duration</b>	01/01/2021 – 12/31/2024
<b>Total Project Value</b>	\$ 500,000
<b>FOA Number</b>	DE-FOA-0002193
<b>Area of Interest</b>	Novel Sensors and Controls for Flexible Generation

Researchers will develop robust heat-flux sensor elements, based on the wire-wound Schmidt Boelter gauge architecture and the transverse Seebeck effect, capable of operating in the challenging high-temperature, corrosive environments within the boilers of coal-fired power plants. The heat-flux sensors will utilize thermoelectric effects to directly transduce the heat-flux input to analog electrical voltage signals and will be constructed from dedicated materials that can withstand oxidative atmospheres at temperatures from 700 to 1200 °C and maintain adequate performance under these conditions for prolonged periods. Rigorous testing and calibration protocols in furnaces and medium-scale fire research facilities will be employed to understand the significance and reliability of the output

signal under a range of dynamic environmental conditions. These conditions will include a range of heat-flux values, temperatures, surface emissivity, cooling rates, flow rates, and concentrations of carbon particulates. If successful, the project will help extend the power industry's real-time heat-flux sensing capabilities to a challenging regime of extreme environments, offering new opportunities to understand the mechanisms by which operational parameters affect the power generation efficiency. Furthermore, adverse effects of overheating, uneven burner operation and deposition of soot and slag can be detected and remediated before experiencing irreversible damages that could lead to shut down.

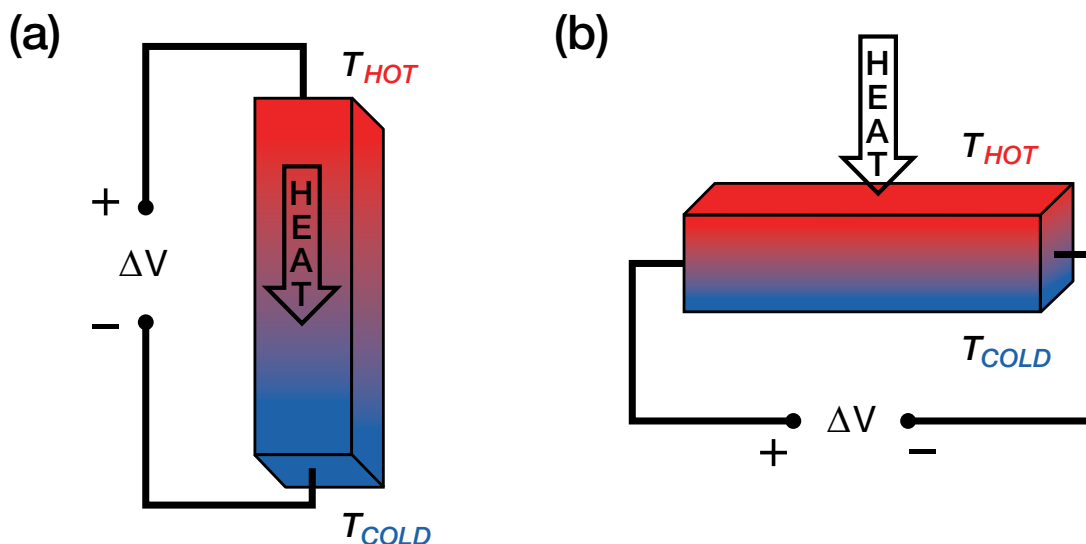

(a) Schematic of the Seebeck effect, (b) Schematic of the transverse Seebeck effect.



## Wireless High Temperature Sensor Network for Boiler Systems

<b>Performer</b>	University of Massachusetts
<b>Award Number</b>	FE0031895
<b>Project Duration</b>	09/04/2020 – 09/03/2025
<b>Total Project Value</b>	\$ 499,958
<b>FOA Number</b>	DE-FOA-0002193
<b>Area of Interest</b>	Novel Sensors and Controls for Flexible Generation

This project aims to develop a new wireless high-temperature sensor network for real-time continuous boiler condition monitoring in harsh environments. The wireless high-temperature sensor network consists of wireless radio frequency (RF) high-temperature sensors with integrated attached antennas for wireless internet-based continuous remote monitoring. Each of the new RF high-temperature sensors is based on a high quality factor RF filter fabricated on 4H silicon carbide semiconductor material capable of measuring high temperatures over 1,800 °C. The integrated antennas are broadband bow-tie RF antennas that can provide efficient signal transmission and reception. The wireless sensor network enables real-time and continuous

monitoring of boiler conditions to achieve smart boiler system management. The high-temperature sensor network enables network-based automatic temperature sensing and data collection which, combined with artificial intelligence algorithms, allow the construction of smart boiler systems with boiler condition management and optimization for significant energy-saving and reliability improvements. The research will also train graduate students in the critical technology areas of high-temperature materials, advanced manufacturing of integrated RF sensors, wireless sensor network communication, cloud computing with high security, and AI-enabled smart systems.

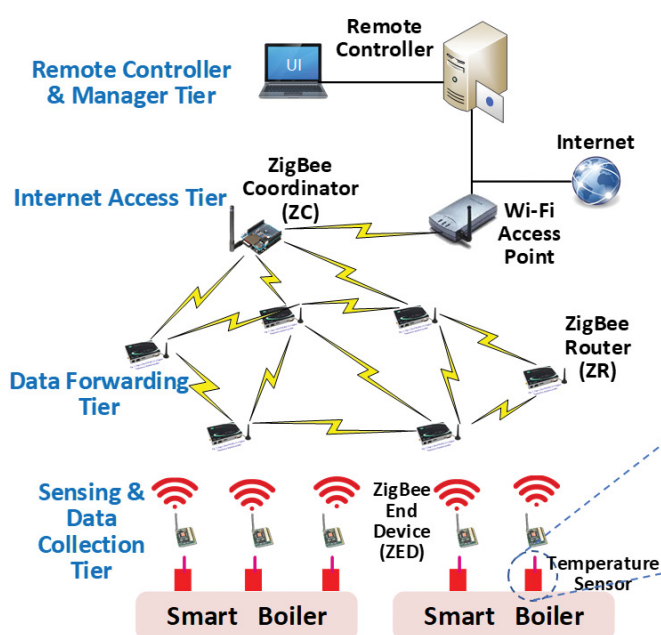

Schematic architecture of the smart boiler wireless sensor network. Each wireless high-temperature sensor is coupled with a ZigBee end device (ZED) to collect and continuously transmit the boiler temperature data in real time. The temperature data will be routed to the remote controller through the wireless mesh network and the internet as well as Wi-Fi access points. Inset: schematic structure of the wireless high-temperature sensor in boilers. It is based on a Lamb RF filter with integrated broadband bow-tie antennas for wireless temperature transfer.

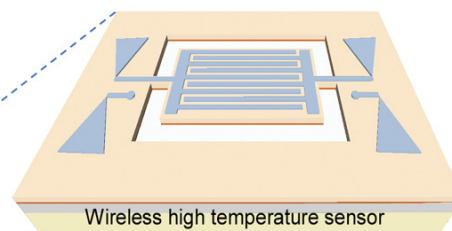

# Incorporating Blockchain/P2P Technology into an SDN-Enabled Cybersecurity System to Safeguard Fossil Fuel Power Generation Systems

<b>Performer</b>	University of North Dakota Energy and Environmental Research Center (UNDEERC)
<b>Award Number</b>	FE0031742
<b>Project Duration</b>	09/01/2019 – 08/31/2024
<b>Total Project Value</b>	\$ 400,000
<b>FOA Number</b>	DE-FOA-0001991
<b>Area of Interest</b>	Cybersecure Sensors for Fossil Power Generation

This project will investigate the functionality and performance of a blockchain/peer-to-peer (P2P)-enhanced, software-defined networking (SDN)-enabled cybersecurity protection system. This cybersecurity system will operate on a group of controllers which form the control plane of an SDN system. The group of SDN controllers determine how traffic flows are handled passing through switches in the SDN forwarding plane. The forwarding switches relay the communications traffic flows among the cyber-capable devices (e.g., monitors and actuators) deployed in the industrial control system (ICS) for managing and controlling the power plant, transformer yard and power bus functions, transmission system, and distribution substations. The actions of handling traffic flows reflect the purpose of an ICS in allowing legitimate flows and blocking suspicious traffic flows pertaining to possible network intrusions or denial-of-service attacks. The actions are expressed in the form of rules which can be programmed into the forwarding switches by the SDN controllers. Cybersecurity protection based on the present SDN technology is susceptible to attacks targeting the control plane or targeting the communications

between the forwarding and the control planes. However, the PIs believe that blockchain/P2P technology can be incorporated into an SDN-based cybersecurity protection system to mitigate the security risks. The prototype of a blockchain/P2P-enhanced cybersecurity protection system can be used to demonstrate a cost-effective reinforcement of the security protection safeguarding the operations of fossil fuel power generation systems. A testbed needs to be developed to examine the technical feasibility of incorporating blockchain/P2P technology into an SDN-enabled cybersecurity protection system, from both interoperability and performance perspectives.

This project will also create a synergy between the University of North Dakota and its project partner, Minnkota Power Cooperative, for addressing the practical need of cybersecurity protection over fossil fuel power generation systems. In the long term, the project is expected to facilitate sustained efforts in advancing ongoing research in emerging technologies to enhance cybersecurity protection in a broader range of applications.

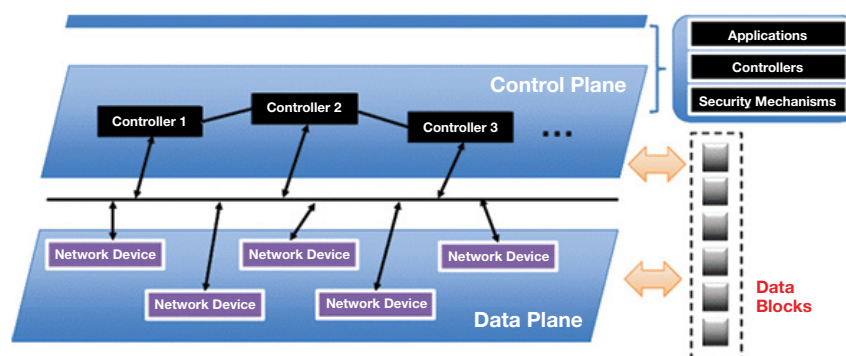

The generic framework of blockchain-based SDN.

## An Autonomous Robotic Inspection System for Coal Ash and Tailings Storage Facilities

<b>Performer</b>	West Virginia University
<b>Award Number</b>	FE0032206
<b>Project Duration</b>	10/01/2022 – 09/30/2025
<b>Total Project Value</b>	\$ 499,846
<b>FOA Number</b>	DE-FOA-0002596
<b>Area of Interest</b>	Automated Component Inspection, Analysis, and Repair Enabled by Robotics

The first objective of this project is the development and programming of an intelligent drone that will autonomously inspect the structural components of a storage facility. The drone will be able to create multispectral and georeferenced images (i.e., thermal and visual) and high-resolution three-dimensional maps of the facility, which will permit the detection of cracks, deformities, and other hazards on the storage facility structures. The second objective of this project is to create artificial intelligence-based hazard detection algorithms that will use the multispectral and

georeferenced images (i.e., thermal and visual) and 3D point clouds collected by the drone to detect hazards in the facility structure that would indicate uncontrolled leakage to the environment or lead to the potential failure of the structure.

The automation of the inspection process, as proposed by this project, has the potential to improve the inspection of such coal ash and tailings storage facilities, thus preventing future accidents and protecting public health and the environment.

## Passive Wireless Sensors for Realtime Temperature and Corrosion Monitoring of Coal Boiler Components Under Flexible Operation

<b>Performer</b>	West Virginia University Research Corporation
<b>Award Number</b>	FE0031912
<b>Project Duration</b>	08/17/2020 – 05/16/2025
<b>Total Project Value</b>	\$ 500,000
<b>FOA Number</b>	DE-FOA-0002193
<b>Area of Interest</b>	Novel Sensors and Controls for Flexible Generation

This project will develop an inexpensive wireless, high-temperature sensor for real-time monitoring of the temperature and corrosion of metal components that are commonly used in coal-fired boilers. This work will focus on the fabrication and testing of harsh-environment, chipless radio-frequency identification (RFID) sensors that will function between 25 °C and 1300 °C in high steam and/or combustion gas environments. Sensor arrays will also be evaluated where each RFID sensor will be designed with a specified frequency band to spatially differentiate the testing site on the metal specimen. Specifically, this project will: (1) design passive wireless RFID patch and interrogator antennas for high-temperature sensing of temperature and corrosion/crack propagation at temperatures up to 1300 °C; (2) develop materials and methods to fabricate a microstrip patch antenna sensor composed of a robust conductive electroceramic pattern and interlayer ceramic coating, and then incorporate this sensor into “peel-and-stick” preforms that will efficiently transfer and bond to the metal specimens of interest; (3) investigate the wireless RFID sensor response in accelerated high-temperature

and high steam environments, and correlate corrosion and cracking mechanisms (and kinetics) with the response of the sensors; (4) investigate the wireless signal acquisition and processing of data transferred in various configurations by multiple sensors within the same environment and through-wall transmission of the signal by a singular RFID sensor; and (5) investigate the passive wireless sensor system developed (and method of transferring the sensor system) for monitoring the temperature and health of metal components in service within a coal-fired power plant. Applications for the passive wireless sensors are numerous within a coal boiler power plant, and these sensors will provide operators additional information over the current state-of-the-art temperature and corrosion sensors. An important strategy for managing cycling damage for flexible operation is through real-time monitoring of localized temperature and health of the various pipework, headers, rotors, and steam chests. This technology permits simplified monitoring of these components, which would greatly reduce the cost and provide valuable localized knowledge of thermal conditions.

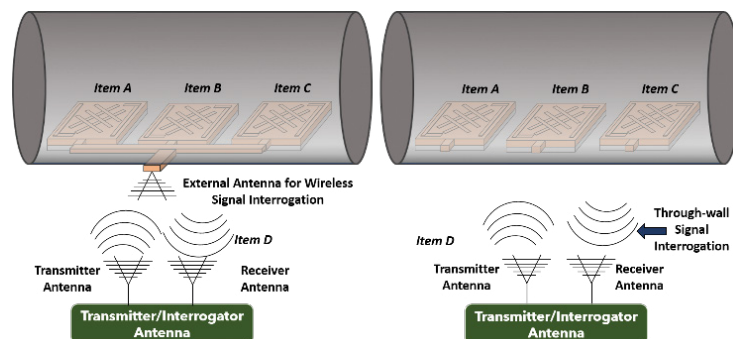

Left: Schematic of the multi-sensor array deposited onto the inner wall of a metal pipe to monitor corrosion rates, where each sensor focuses on a specific band range read by an external interrogator antenna; Right: schematic of the alternative interrogation method, where through-wall transmission will be tested in order to eliminate the need for an access hole.

## Advanced Modeling and Process-Materials Co-Optimization Strategies for Swing Adsorption Based Gas Separations

<b>Performer</b>	Carnegie Mellon University (CMU)
<b>Award Number</b>	FE0032069
<b>Project Duration</b>	09/13/2021 – 09/12/2024
<b>Total Project Value</b>	\$ 400,000
<b>FOA Number</b>	DE-FOA-0002398
<b>Area of Interest</b>	Process and Materials Co-Optimization for the Production of Blue Hydrogen

Integrating carbon capture with fossil fuel-based technologies currently stands as the most realistic pathway for enabling a hydrogen economy. To realize this, it is crucial to develop novel, energy-efficient, adsorption-based gas separation processes that are coupled with purpose-designed microporous materials serving as the adsorbents, in order to enable needed efficiencies in either a pre-combustion, oxyfuel combustion, or post-combustion carbon capture setting. In this project, mathematical models and computational methodologies are developed to enable the design of novel gas separation processes, along with the microporous materials they rely upon, in a co-optimization paradigm. This project specifically focuses on swing adsorption, considered to be the most promising technology for selectively adsorbing and separating gases at massive scales. Swing adsorption achieves the gas separation by utilizing the difference in pressure-dependent and/or temperature-dependent equilibria and kinetics that different gases exhibit when adsorbing inside solid sorbents. The high-fidelity process modeling effort will be coupled with data-driven materials design methodologies, realizing a novel integrated process-materials co-optimization framework that will be implemented within DOE's IDAES Integrated Platform, an open-source computational platform for the modeling and optimization of advanced energy systems. Harnessing data from open-source databases,

the materials optimization effort will involve the automated learning of high-quality adsorption isotherms in forms that can be seamlessly incorporated within high-fidelity process models, in order to enable the direct search over the material's molecular structure. Such materials optimization will be conducted simultaneously, in an integrated fashion, with process optimization that considers both cycle configuration and flowsheet design. Specific emphasis will be given to the development of a smart hierarchy of models that navigates the trade-off between model tractability and model fidelity, in a user-configurable model interface that empowers IDAES users to control this trade-off in their own application.

The proposed framework will enable the ever-growing base of IDAES users, from industry to government to academia, to design gas separation processes at multi-scale levels, supporting their efforts to develop new technologies and systems for hydrogen production and to determine the most cost-efficient pathways toward a hydrogen economy. Example systems in which the developed methodologies could be applied include carbon capture for combustion-based power generation and hydrogen purification for gasification and syngas-based technologies. There are numerous other application contexts that require gas separations and for which innovations resulting from this project could also be leveraged.

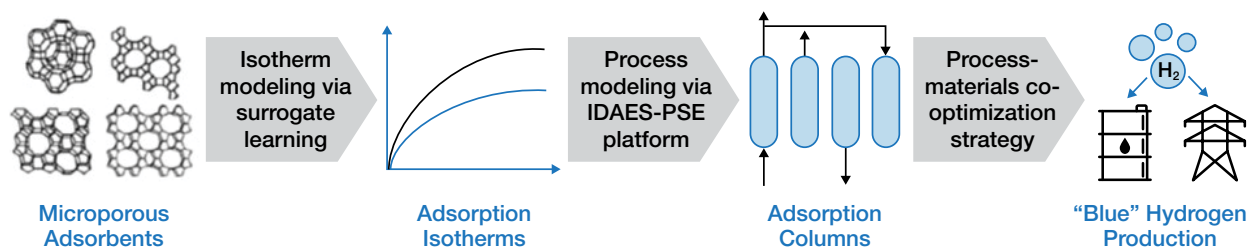

Conceptual design of the project.

## Developing Drag Models for Non-Spherical Particles through Machine Learning

<b>Performer</b>	Johns Hopkins University
<b>Award Number</b>	FE0031897
<b>Project Duration</b>	09/01/2020 – 08/31/2024
<b>Total Project Value</b>	\$500,000
<b>FOA Number</b>	DE-FOA-0002193
<b>Area of Interest</b>	Machine Learning for Computational Fluid Dynamics

The overarching goal of this project is to produce comprehensive experimental and numerical datasets for gas-solid flows in well-controlled settings to understand the aerodynamic drag of non-spherical particles in the dense regime. The datasets and the gained knowledge will be utilized to train deep neural networks in TensorFlow™ to formulate a general drag model for use directly in NETL MFiX-DEM module. This will help to advance the accuracy and prediction fidelity of the computational tools that will be used in designing and optimizing fluidized beds and chemical looping reactors. The unique combination of DNS and high-resolution experiments, the capability to reduce the number of parameters, and the machine-learning-

based data processing, will allow for developing a drag model that has unprecedented accuracy and breadth of regimes to which it can be applied. It will critically advance the physical understanding of particle-particle and particle-gas interaction in gas-solid flows. This research program will also provide a comprehensive database to inform and validate MFiX and other numerical models for multiphase flows. Finally, students that will be involved in this project will gain experience in modern computational, experimental, and machine learning methods. The rigorous scientific training will prepare the students to become future leaders in promoting and revolutionizing fossil energy.

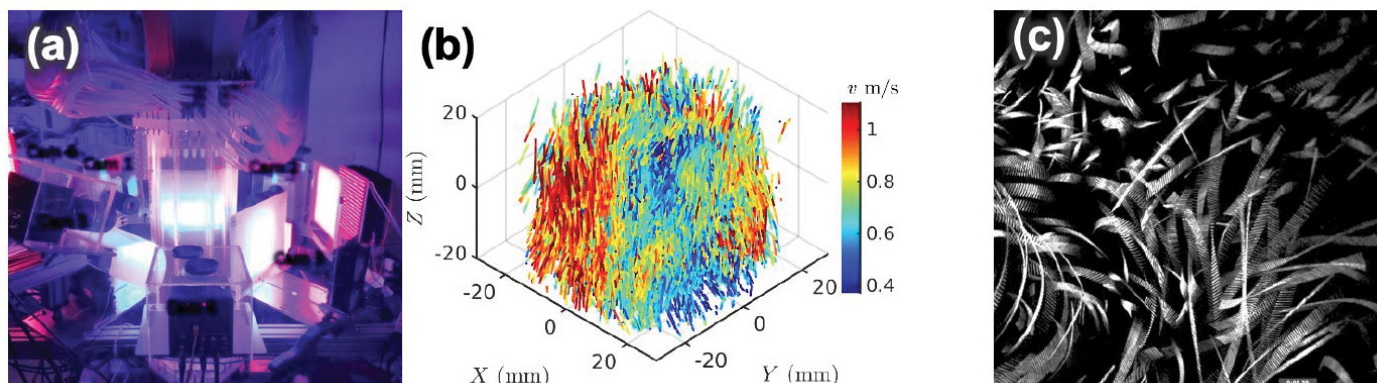

(a) Picture of the 3D dense particle tracking system that has already been integrated in another similar vertical setup.  
 (b) Dense particle trajectories collected from the same system in (a), color-coded by individual's particle velocity.  
 (c) Long-exposure picture of dense fibers moving in turbulence conducted by PI Ni.

## Systems Analysis for Advancing Coal/Waste Coal-Biomass Co-Firing Power Plants with Deep Carbon Capture, Utilization and Storage Toward Net-Zero Emissions

<b>Performer</b>	University of Wyoming
<b>Award Number</b>	FE0032193
<b>Project Duration</b>	10/01/2022 – 09/30/2024
<b>Total Project Value</b>	\$ 399,284
<b>FOA Number</b>	DE-FOA-0002596
<b>Area of Interest</b>	Techno-Economic Analysis and Lifecycle Analysis Screening of Net-Zero or Net-Negative Greenhouse Gas Emission, Carbon Capture and Storage-Enabled, Coal/Waste Coal and Biomass Power Production

The major objectives of the proposed project are to (1) estimate the life cycle greenhouse gas (GHG) emissions of pulverized coal/waste coal-biomass co-firing power plants with carbon capture, utilization and storage (CCUS) using liquid solvents for 95–99% carbon dioxide (CO<sub>2</sub>) capture; (2) determine the breakeven co-firing level of biomass required to achieve net-zero GHG emissions on a life cycle basis, including its dependence on key factors; and (3) quantify bounding conditions for the techno-economic performance of net-zero CCUS-enabled power production leveraging waste coal and biomass as feedstocks in both deterministic and probabilistic forms. To achieve these objectives, this project proposes an integrated systems modeling framework that combines techno-economic analysis (TEA) for CCUS-enabled power production with life cycle analysis (LCA) in both deterministic and probabilistic forms.

This project could provide major R&D organizations with the integrated modeling capability needed to screen CCUS-enabled power generation systems for net-zero energy production and determine the R&D priorities and targets

while transiting to a carbon-free power future. It is intended that a significant output from the proposed project will be a state-of-the-art tool to assist universities and colleges with training the next generation of engineers and scientists and supporting early-stage research on fossil energy and carbon management.

This project will also enhance the Integrated Environmental Control Model (IECM) by adding new integrated TEA and LCA features, which will empower students with the capability to design advanced carbon capture technologies for deep CO<sub>2</sub> capture and explore sustainable cost-effective pathways of net-zero power production leveraging waste coal and biomass as feedstocks when applied in a full-scale power generation system. The enhanced IECM will be publicly available for teaching, education, and research to train the next generation of scientists and engineers on fossil energy and carbon management. This project will directly train one PhD student and one postdoctoral researcher on deep decarbonization of fossil energy.

## ABBREVIATIONS

3D .....	three-dimensional	FOA .....	funding opportunity announcement
5G-TSN .....	fifth-generation time-sensitive networking	FP .....	Fabry-Perot
ALD .....	atomic layer deposition	GHG .....	greenhouse gas
AM .....	additive manufacturing	GIS .....	geographic information systems
ANN .....	artificial neural network	GNR .....	graphene nanoribbon
As .....	arsenic	GQD .....	graphene quantum dot
BECCS .....	Bio-Energy with Carbon Capture and Storage	GTAW .....	gas tungsten arc welding
BURP2 .....	Biogas Utilization in Refuse Power Plants	H <sub>2</sub> .....	hydrogen
CCS .....	carbon capture and storage	H <sub>2</sub> O .....	water
CCUS .....	carbon capture utilization and storage	HBCU-MSI .....	Historically Black Colleges and Universities and Minority-Serving Institutions
CFD .....	computational fluid dynamics	ICME .....	integrated computational materials engineering
CFPP .....	coal-fired power plant	ICS .....	industrial control system
CMU .....	Carnegie Mellon University	IDAES .....	Institute for the Design of Advanced Energy Systems
CO <sub>2</sub> .....	carbon dioxide	IECM .....	Integrated Environmental Control Model
CSEF .....	creep-strength-enhanced ferritic	IN .....	Inconel
cSETR .....	Center for Space Exploration and Technology Research	LCA .....	life cycle analysis
CSULA .....	California State University, Los Angeles	LCOE .....	levelized cost of electricity
DECS .....	distributed edge computing service	MFiX .....	Multiphase Flow with Interphase eXchanges
DNN .....	deep neural network	MFiX-DEM .....	Multiphase Flow with Interphase eXchanges Discrete Element Model
DNS .....	direct numerical simulation	ML .....	machine learning
DOE .....	U.S. Department of Energy	MPa .....	Megapascal
E2E .....	end-to-end	MSW .....	municipal solid waste
EM .....	electromagnetic	MTU .....	Michigan Technological University
EMI .....	electromagnetic interference	NDE .....	non-destructive evaluation
Er <sub>2</sub> O <sub>3</sub> .....	erbium oxide	NETL .....	National Energy Technology Laboratory
Er <sub>2</sub> Ti <sub>2</sub> O <sub>7</sub> .....	erbium titanate	NV .....	nitrogen vacancy
Fe-Al .....	iron-based alumina nanocomposites	OTP .....	Otter Tail Power
Fe/SiC .....	iron-based catalysts supported on silicon carbide	P2P .....	peer-to-peer
FECM .....	U.S. Department of Energy's Office of Fossil Energy and Carbon Management	PI .....	principal investigator
FGD .....	flue gas desulfurization	PPC .....	pocket personal computer



PR-DNS.....	particle-resolved direct numerical simulation	STEM .....	science, technology, engineering, and mathematics
PSC.....	point-source carbon capture	TCD.....	thermo-catalytic decomposition
PWHT.....	post-weld heat treatment	TEA .....	technoeconomic analysis
QoS.....	quality of service	TiO .....	titanium oxide
RAB .....	Rotating Algal Biofilm	TRL .....	technology readiness level
R&D.....	research and development	TXST .....	Texas State University
RF .....	radio frequency	UC.....	University of California
RFID .....	radio-frequency identification	UCR .....	University Carbon Research
RVI .....	robotic visual inspection	UND .....	University of North Dakota
SCADA .....	supervisory control and data acquisition	UNDEERC .....	University of North Dakota Energy and Environmental research Center
SCS.....	solution combustion synthesis	UTEP.....	University of Texas at El Paso
SDN .....	software-defined networking	UTR.....	University Training and Research (NETL program)
Se .....	selenium	UTRGV .....	University of Texas Rio Grande Valley
SiC .....	silicon carbide	ZED .....	ZigBee end device
SmB <sub>8</sub> .....	samarium hexaboride	ZrB <sub>2</sub> .....	zirconium diboride
SPM-OL .....	scanning probe microscopy-based oxidation lithography		

## NOTES

## CONTACTS

### **Robie Lewis**

*Technology Manager  
University Training and Research*

304-285-1308

[robie.lewis@netl.doe.gov](mailto:robie.lewis@netl.doe.gov)

### **Omer Bakshi**

*Technical Project Officer  
Integrated Carbon Management Team*

412-386-4645

[omer.bakshi@netl.doe.gov](mailto:omer.bakshi@netl.doe.gov)

### **Seth Lawson**

*Team Supervisor  
Integrated Carbon Management Team*

304-285-0578

[seth.lawson@netl.doe.gov](mailto:seth.lawson@netl.doe.gov)

## WEBSITES:

<https://netl.doe.gov/carbon-management/university-training>

## ACKNOWLEDGMENTS

The University Training and Research Portfolio was developed with the support of many individuals. Key roles were played by principal investigators, federal project managers, the technology manager, the supervisor, and National Energy Technology Laboratory site-support contractors.



1450 Queen Avenue SW  
**Albany, OR** 97321-2198  
541-967-5892

3610 Collins Ferry Road  
P.O. Box 880  
**Morgantown, WV** 26507-0880  
304-285-4764

626 Cochran Mill Road  
P.O. Box 10940  
**Pittsburgh, PA** 15236-0940  
412-386-4687

Program staff are also located in  
**Houston, TX** and **Anchorage, AK.**

Visit us: [www.NETL.DOE.gov](http://www.NETL.DOE.gov)

**@NationalEnergyTechnologyLaboratory**

**@NETL\_DOE**

**@NETL\_DOE**



U.S. DEPARTMENT OF  
**ENERGY**

April 2024