



WATER MANAGEMENT PROJECT PORTFOLIO 2020



U.S. DEPARTMENT OF
ENERGY



NATIONAL
ENERGY
TECHNOLOGY
LABORATORY

DISCLAIMER

This report was prepared as an account of work sponsored by an agency of the United States Government. Neither the United States Government nor any agency thereof, nor any of their employees, makes any warranty, express or implied, or assumes any legal liability or responsibility for the accuracy, completeness, or usefulness of any information, apparatus, product, or process disclosed, or represents that its use would not infringe privately owned rights. Reference herein to any specific commercial product, process, or service by trade name, trademark, manufacturer, or otherwise does not necessarily constitute or imply its endorsement, recommendation, or favoring by the United States Government or any agency thereof. The views and opinions of authors expressed herein do not necessarily state or reflect those of the United States Government or any agency thereof.

CONTENTS

Introduction	5
Water Management	7
ENERGY WATER ANALYSIS	8
Carnegie Mellon University (CMU): Trace Element Sampling and Partitioning Modeling to Estimate Wastewater Composition and Treatment Efficacy at Coal Generators.....	9
Lehigh University: Coal-Fired Power Plant Configuration and Operation Impact on Plant Effluent Contaminants and Conditions.....	10
National Energy Technology Laboratory (NETL): Water Management for Power Systems: Impact of Water Use of Power Systems – Task 5	11
Sandia National Laboratories (SNL): Water Atlas Extension	12
INCREASING WATER EFFICIENCY AND REUSE	13
Advanced Cooling Technologies, Inc.: A Novel Steam Condenser with Loop Thermosyphons and Film-Forming Agents for Improved Heat Transfer Efficiency and Durability.....	14
Gas Technology Institute (GTI): Enhanced Cooling Tower Technology for Power Plant Efficiency Increase and Operating Flexibility.....	15
Infinite Cooling, Inc.: Water Recovery from Cooling Tower Plumes.....	16
Interphase Materials, Inc.: Application of Heat Transfer Enhancement (HTE) System for Improved Efficiency of Power Plant Condensers.....	17
Massachusetts Institute of Technology: Capillary-Driven Condensation for Heat Transfer Enhancement in Steam Power Plants	18
Nelumbo Inc.: Enhancing Steam-Side Heat Transfer via Microdroplet Ejection using Inorganic Coatings	19
Oak Ridge National Laboratory (ORNL): Enhanced Steam Condenser for Power Generation Applications	20
University of North Dakota Energy and Environmental Research Center (UNDEERC): Wastewater Recycling Using a Hygroscopic Cooling System	21
Virginia Polytechnic Institute and State University: Novel Patterned Surfaces for Improved Condenser Performance in Power Plants.....	22
TREATING ALTERNATIVE SOURCES OF WATER	23
Electric Power Research Institute, Inc.: Demonstrations of Holistic, Lower Cost/Energy Effluent Water Management Approaches for Coal-Fired Energy Plants	24

Gas Technology Institute (GTI): Co-Generation Wastewater Treatment at Coal-Fired Energy Plants	25
Montrose Water and Sustainability Services, Inc.: Flue-Gas Desulfurization Effluent Management Using an Innovative Low-Energy Biosorption Treatment System to Remove Key Contaminants.....	26
National Energy Technology Laboratory (NETL): Water Management for Power Systems: Concentrating Wastewater Effluent Streams – Task 4	27
National Energy Technology Laboratory (NETL): Water Management for Power Systems: Guiding R&D for Treatment of Coal Power Plant Effluent Streams – Task 2	28
National Energy Technology Laboratory (NETL): Water Management for Power Systems: Selective Removal of Heavy Metals from Effluent Streams – Task 3.....	29
SRI International: Development of a High Efficient Membrane-Based Wastewater Management System for Thermal Power Plants.....	30
University of California - Los Angeles: Applying Anodic Stripping Voltammetry to Complex Wastewater Streams for Rapid Metal Detection	31
University of Illinois at Urbana-Champaign: Energy Efficient Waste Heat Coupled Forward Osmosis for Effluent Water Management at Coal-Fired Power Plants.....	32
University of Kentucky Research Foundation: Intensified Flue Gas Desulfurization Water Treatment for Reuse, Solidification, and Discharge	33
West Virginia State University: Dev. Cost-Effective Biological Removal Technology for Selenium & Nitrate from Flue Gas Desulfurization Wastewater from Existing Power Generating Facility	34
West Virginia University Research Corporation: Produced Water and Waste Heat-Aided Blowdown Water Treatment: Using Chemical and Energy Synergisms for Value Creation	35

Abbreviations	36
----------------------------	----

Contacts	37
-----------------------	----

INTRODUCTION

NETL's Crosscutting Research Program matures novel technologies for commercialization that can enhance new and existing fossil-fired power plants. Six research and development (R&D) programs target enhanced fossil energy systems: High Performance Materials; Sensors, Controls, and Cybersecurity; Modeling, Simulation and Analysis; Water Management; Energy Storage; and University Training and Research.

The goals are to create transformational technologies that improve plant efficiency and security, reduce water consumption, and reduce costs, all under a single research umbrella. The research is leading to enhancements to the fleet such as improved plant efficiency, new ways to address the challenges of load following, better ways to counter cyber intrusions, and advancements in affordable, scalable technical solutions. Because of the broad scope of the Crosscutting Research Program's portfolio, its technologies often have applicability to other energy sectors such as oil and natural gas infrastructure and aviation (both commercial and military).

On behalf of the U.S. Department of Energy's Office of Fossil Energy, NETL pursues crosscutting R&D by collaborating with other government agencies, world-renowned national labs, entrepreneurs, industry, and academic institutions. Crosscutting Research efforts include sponsorship of two long-running university training programs that prepare the next generation of scientists and engineers to meet future energy challenges. These are the University Coal Research (UCR) program and the Historically Black Colleges and Universities and Other Minority Institutions (HBCU-OMI) program. By working with students on the university level, the efforts ensure that key technologies in areas including advanced manufacturing, cybersecurity, smart data analytics, and high-performance computing will be integrated into fossil plants of the future.

In combination, these investments in innovation, informed by private sector stakeholders, enable more comprehensive risk assessment and techno-economic analysis, increase the resiliency of the nation's fossil energy infrastructure, and enable the adoption of cutting-edge data technologies for plant owners and operators.

Sensors and Controls: The Sensors and Controls program improves fossil energy power generation with sensors, distributed intelligent control systems, and increased security. Advanced sensors and controls provide pivotal insights into optimization of plant performance and increasing plant reliability and availability. NETL tests and matures novel sensor and control systems that are operable in coal-fired power plants, capable of real-time measurements, improve overall plant efficiencies, and allow for more effective ramp rates. Given the crosscutting nature of sensors and controls, these technologies will also benefit natural gas power generation and other harsh-environment applications.

The Crosscutting Sensors and Controls program explores advances within and the integration of technologies across the following primary research areas: Harsh Environment Sensors, Robotic Inspection, Advanced Controls and Cyber Physical Systems, and Cyber Security.

High Performance Materials: High Performance Materials drives to characterize, produce, and certify cost-effective alloys and other high-performance materials suitable for the extreme environments found in fossil-based power-generation systems. NETL supports and catalyzes a robust domestic materials supply chain that prepares materials for advanced ultra-supercritical (AUSC) steam cycles and spinoff applications. The work also enables research in suitable materials for supercritical carbon dioxide (sCO₂) cycles that yield higher thermal efficiencies and supports the existing fossil fleet with materials solutions that enhance flexibility and reliability.

The Crosscutting Materials program works to accelerate the development of improved steels, superalloys, and other advanced alloys to address challenges of both the existing fleet and future power systems. Materials of interest are those that enable components and equipment to perform in the high-temperature, high-pressure, corrosive environments of an advanced energy system with specific emphasis on durability, availability, and cost both within and across each of four primary platforms: Advanced Manufacturing, Advanced Structural Materials, and Computational Materials Design.

Modeling, Simulation and Analysis: Modeling, Simulation and Analysis (MSA) focuses on developing and applying advanced computational tools at multiple scales: atomistic, device, process, grid, and market scales, to accelerate development and deployment of fossil fuel technologies.

Research in this area provides the basis for the simulation of engineered devices and systems to better predict and optimize the performance of fossil fuel power generating systems.

Computational design methods and concepts are required to significantly improve performance, reduce the costs of existing fossil energy power systems, and enable the development of new systems and capabilities such as advanced ultrasupercritical combustion and hydrogen turbines.

This effort combines theory, computational modeling, advanced optimization, experiments, and industrial input to simulate complex advanced energy processes, resulting in virtual prototyping. The research conducted in the MSA R&D develops accurate and timely computational models of complex reacting flows and components relevant to advanced power systems. Model development and refinement is achieved through in-house research and partnerships to utilize expertise throughout the country.

Water Management: Water Management addresses competing water needs and challenges through a series of dynamic and complex models and analyses that are essential in informing and deciding between priority technology choices. The program encompasses the need to minimize any potential impacts of power plant operations on water quality and availability. Analyzing and exploring plant efficiency opportunities can reduce the amount of water required for fossil energy operations.

New water treatment technologies that economically derive clean water from alternative sources will allow greater recycling of water within energy extraction and conversion as well as carbon storage processes. This helps reduce the amount of total water demand within fossil energy generation.

The program leads a critical national effort directed at removing barriers to sustainable, efficient water and energy use; developing technology solutions; and enhancing the understanding of the intimate relationship between energy and water resources. Water Management R&D focuses its research in three chief areas: increasing water efficiency and reuse, treatment of alternative sources of water, and energy-water analysis. These research areas encompass the need to minimize potential impacts on water quality and availability.

Energy Storage: FE's Advanced Energy Storage program aims to address the needs and challenges of fossil assets through the integration of energy storage technologies. As the penetration of variable renewable energy increases, energy storage at the generation site will be essential to a resilient and flexible electricity network. Energy storage also benefits the environment through optimization of fossil generation and by enabling additional renewables on the grid to reliably transmit their energy to end users. Program activities include plant- and system-level analyses, conceptual and detailed engineering designs, breakthrough R&D on innovative energy storage concepts, and targeted R&D on component and system-integrated energy storage technologies.

University Training and Research: University Training and Research supports two of the longest-running university training programs, the Historically Black Colleges and Universities (HBCU) and Other Minority Institutions (OMI) and the University Coal Research (UCR) programs, to support the education of students in the area of coal science is promoted through grants to U.S. colleges and universities that emphasize FE strategic goals. These training programs were designed to increase the competitiveness of universities in fossil energy research and discoveries. The student-led research programs advance energy technologies and allow for expansion of energy production while simultaneously facilitating energy sector job growth. The Outreach Initiative provides opportunities for qualified students and post-doctoral researchers to hone their research skills with NETL's in-house scientists.

WATER MANAGEMENT

In the United States, water is a fixed resource subject to competing demands. Water is closely linked to energy, as thermoelectric power generation accounts for over 40 percent of freshwater withdrawals and over 3 percent of freshwater consumption in the United States. Available Water Remaining in the United States (AWARE-US), a spreadsheet-based model of seasonal water stress developed with NETL at Argonne National Lab, categorizes U.S. counties in terms of a characterization factor which is the potential to deprive other users when consuming water in an area. Additionally, NETL published the 2018 Water Brief for Fossil Energy Applications for a discussion on water demand and consumption throughout the contiguous United States. Data utilized in the Water Brief was compiled by Sandia National Labs.

The Water Management R&D program addresses competing water demands through a series of dynamic and complex models and analyses that are helpful in determining priority technology R&D initiatives, accepting the need to minimize potential impacts of power plant operations on water quality and availability. The program leads a critical national effort to remove barriers to sustainable, efficient water and energy use; develop technology solutions; and enhance understanding of the intimate relationship between energy and water resources.

New water treatment technologies that economically derive clean water from alternative sources will allow greater recycling of water within energy extraction and conversion as well as carbon storage processes. This will help reduce the amount of total water demand for fossil-fueled power generation.

Water Management R&D focuses research in three chief areas:



Energy Water Analysis

The complex relationship between energy and water is constantly developing. The multiple components that impact the system can be modeled and analyzed to better inform decision makers and scientists alike. This area helps prioritize research objectives through analyses of the behavior of the water-energy system.



Increasing Water Efficiency and Reuse

There is an inextricable link between water and energy, and it is increasingly important to use water effectively throughout the power generation sector. This research area aims to advance concepts for both new and existing plants to minimize water intake and use. Examining plant cycles and testing new efficient processes can lead to not only reduced water intake, but also lower overall operating costs.



Treating Alternative Sources of Water

The identification and treatment of alternative sources of water (such as brackish water) and effluent streams offer opportunities for scientists to address energy-water system challenges. This area focuses on furthering technology to utilize alternative water sources that span multiple facets of R&D including considerations of capital costs, operating costs, and system integration.

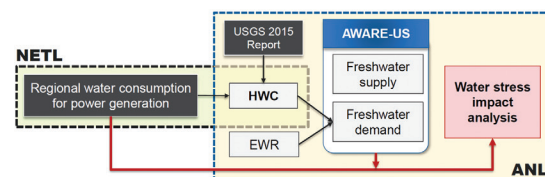

Role of AWARE-US in Water Stress Analysis.

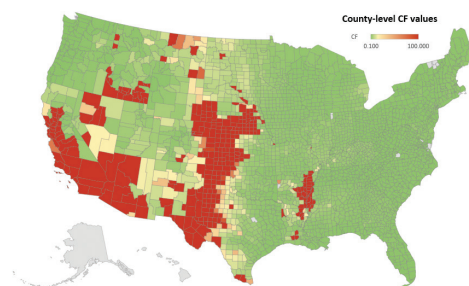

Characterization factors (August) for U.S. counties.

ENERGY WATER ANALYSIS

Carnegie Mellon University (CMU):

Trace Element Sampling and Partitioning Modeling to Estimate Wastewater Composition and Treatment Efficacy at Coal Generators 9

Lehigh University:

Coal-Fired Power Plant Configuration and Operation Impact on Plant Effluent Contaminants and Conditions 10

National Energy Technology Laboratory (NETL):

Water Management for Power Systems: Impact of Water Use of Power Systems – Task 5..... 11

Sandia National Laboratories (SNL):

Water Atlas Extension 12

Trace Element Sampling and Partitioning Modeling to Estimate Wastewater Composition and Treatment Efficacy at Coal Generators

Performer	Carnegie Mellon University (CMU)
Award Number	FE0031646
Project Duration	09/10/2018 – 09/09/2021
Total Project Value	\$ 400,000
Collaborators	Duke University; University of Kentucky
Technology Area	University Training and Research

Carnegie Mellon University researchers will sample pulverized-coal-fired power plants (CFPPs) owned and operated by Louisville Gas & Electricity–Kentucky Utilities (LGE-KU) to build a predictive model that will enable utility decision makers, academic researchers, and policymakers to simulate trace element (TE) emissions from such plants. Samples taken during baseload and cycling conditions will be used to develop and validate an open-source, easy-to-implement trace element partitioning model using publicly available datasets, literature studies of trace element partitioning, and sampling data from LGE-KU coal-fired plants to estimate trace element partitioning in air pollution control devices (APCDs) between the gas, liquid, and solid phases exiting boilers and flue gas treatment trains. The project team will use estimates of the liquid phase trace element concentration in flue gas desulfurization (FGD)

wastewater to estimate trace element behavior in water pollution control devices (WPCDs) and evaluate treated wastewater effluent concentrations for compliance with the Effluent Limitations Guidelines and Standards for the Steam Electric Power Generating Point Source Category (ELGs). The team will then develop cost estimates of established and emerging wastewater treatment trains to identify the most cost-effective approaches to comply with the ELGs.

It is anticipated that this project will create an open-source predictive model of trace element partitioning to solid, liquid, and gas phases at coal-fired power plants, establish a range of FGD wastewater chemistries for existing and new plants, model costs for biological and emerging selenium removal technologies, and quantify the impact of non-steady state operation on trace element partitioning.

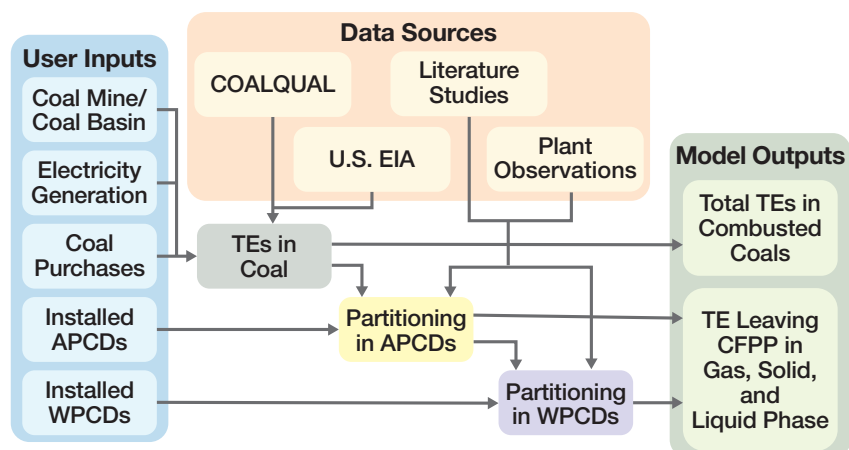

Framework for the Trace Element Partitioning Model.

Coal-Fired Power Plant Configuration and Operation Impact on Plant Effluent Contaminants and Conditions

Performer	Lehigh University
Award Number	FE0031654
Project Duration	09/01/2018 – 08/31/2021
Total Project Value	\$ 400,000
Collaborator	Western Kentucky University
Technology Area	University Training and Research

Lehigh University, working with Western Kentucky University, will characterize coal contaminants in power plant wastewater as a function of coal type, plant type, plant operational profile, environmental controls, water treatment technology, and effluent species. Multiple utility companies will provide access to their coal-fired power plants and in-kind support for testing and data and sample collection from flue gas desulfurization wastewater discharge and treated water tank discharge effluent streams. Effluent samples will be analyzed for mercury, arsenic, selenium, nitrate/nitrite, and bromide. Coal sample analyses will include proximate analysis (moisture, volatile matter, ash, and fixed carbon); ultimate analysis (carbon, hydrogen, nitrogen, sulfur, ash,

and oxygen); trace elemental analysis (mercury, arsenic, and selenium); and anions analysis (bromide, nitrate + nitrite).

The results of the analyses obtained from this project will trace effluent conditions as a function of coal type, unit configuration, unit operation profile, and environmental control strategy, and will describe levels of uncertainty of the analysis. These results will provide feedback information about the impact of fuel type on effluents and help future decisions on wastewater compliance. Participation of students will encourage new research ideas and provide valuable training opportunities for future U.S. scientists and engineers.

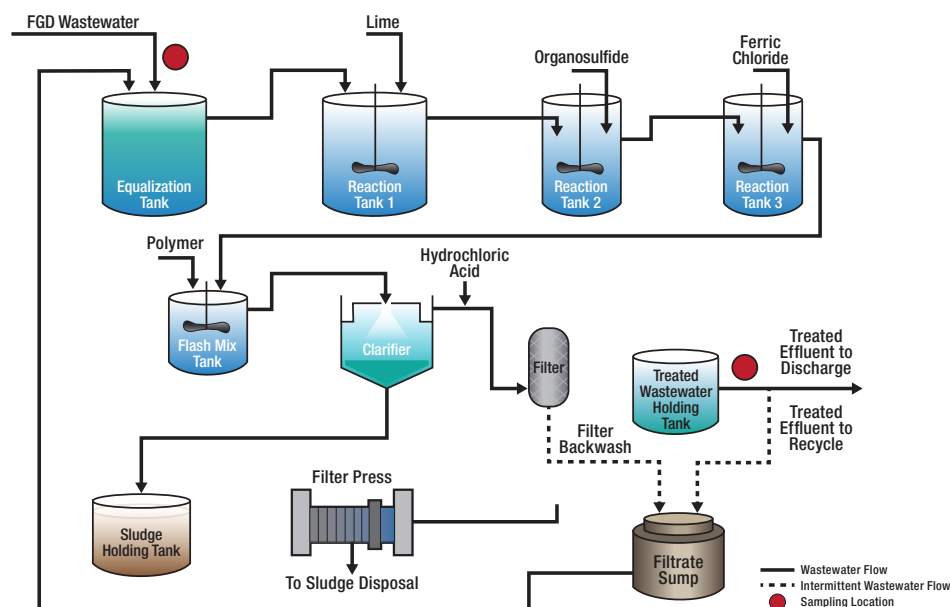

Sampling locations for wastewater chemical precipitation system.

Water Management for Power Systems: Impact of Water Use of Power Systems – Task 5

Performer	National Energy Technology Laboratory (NETL)
Award Number	FWP-1022428 Task 5
Project Duration	04/01/2018 – 03/31/2020
Total Project Value	\$ 240,000
Technology Area	Plant Optimization Technologies

The interface of energy and water, or the water-energy nexus, can be defined as the many relationships between energy and water that are necessary to ensure an adequate supply of both resources for every purpose. Understanding the intertwining nature of water-energy interactions is the key to determining how to make the most efficient use of these critical resources, both for short-term economic benefit and for longer-term societal and environmental sustainability. A summary comparison of water and energy issues shows a striking correspondence between issues on the water side and issues on the energy side. The immediacy of these issues lends urgency to the effort to understand and

manage the water-energy nexus. The objective of this task is to obtain and investigate current water data on individual plant- and fleet-wide water use, water stresses due to power generation, and how water stresses impact power plant operations.

Models and software developed under this task will provide information on the impacts of water use by power plants that can be used by existing coal power plants to make investment decisions on when and what type of equipment to purchase to reduce water consumption. Understanding the impact of water use on power generating systems is critical to guide program direction, goals, and research.

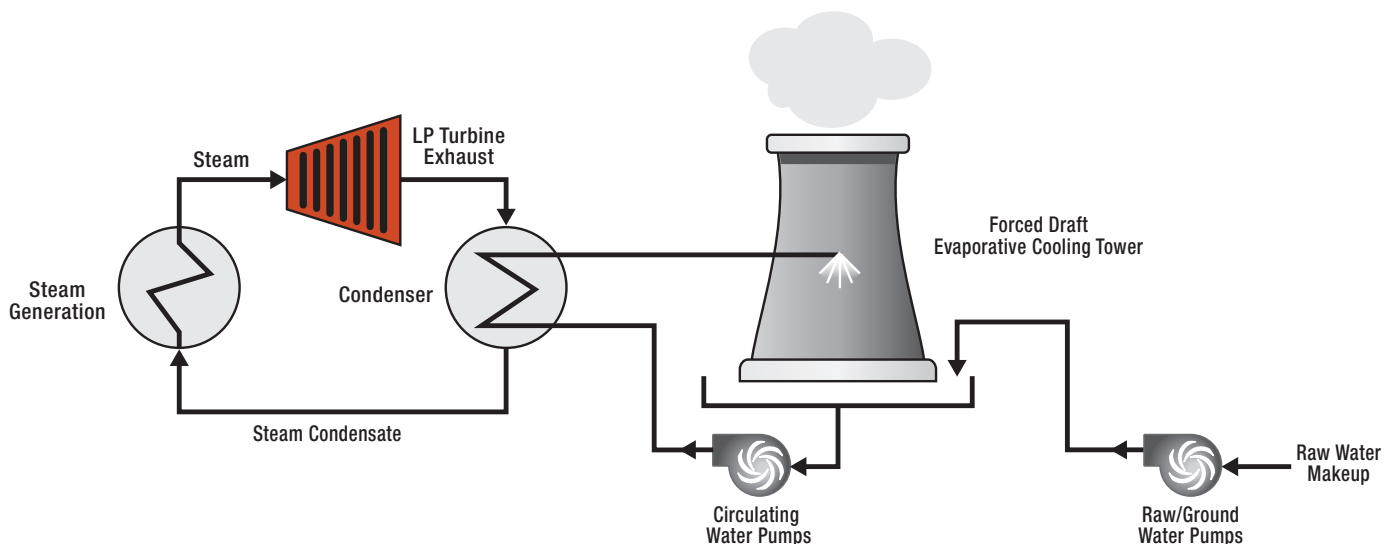

Flow of water in a power plant.

Water Atlas Extension

Performer	Sandia National Laboratories (SNL)
Award Number	FWP-18-021409
Project Duration	10/01/2018 – 09/30/2020
Total Project Value	\$ 700,000
Technology Area	Plant Optimization Technologies

A water database, called the Water Atlas, has been previously developed by Sandia to support energy sector planning. The Water Atlas includes estimates of water availability at the watershed level (8-digit Hydraulic Unit Code [HUC], which corresponds to roughly 2250 watersheds) for the lower 48 states of the United States. These metrics have been developed for five sources of water including fresh surface water and groundwater, appropriated water, municipal wastewater, and shallow brackish groundwater. The compiled set of water availability data is unique in that it considers multiple sources of water; accommodates institutional controls placed on water use; is accompanied by cost estimates to access, treat, and convey each unique source of water; and is compared to projected future growth in consumptive water use to 2030. This current scope of work addresses efforts to extend the Water Atlas in three

important ways. First, the database will be extended to include water data for Alaska and Hawaii. Second, the Water Atlas will be extended to include data on power plant water ownership; particularly, details on where each power plant gets its water and any potential constraints on water deliveries in times of drought. Finally, the database will be extended by adding a metadata layer that contains specifics concerning the origins of the water availability, cost, and future use data (including past and present data entries).

The Water Atlas provides two broad benefits to the electric power industry. First, the compiled water availability/cost data provide a basis for determining where limited water supply could impact siting decisions for new thermal generation. Second, this database helps to better understand the physical and regulatory risks posed to thermal power plant operations by extremes in source water supply and quality.

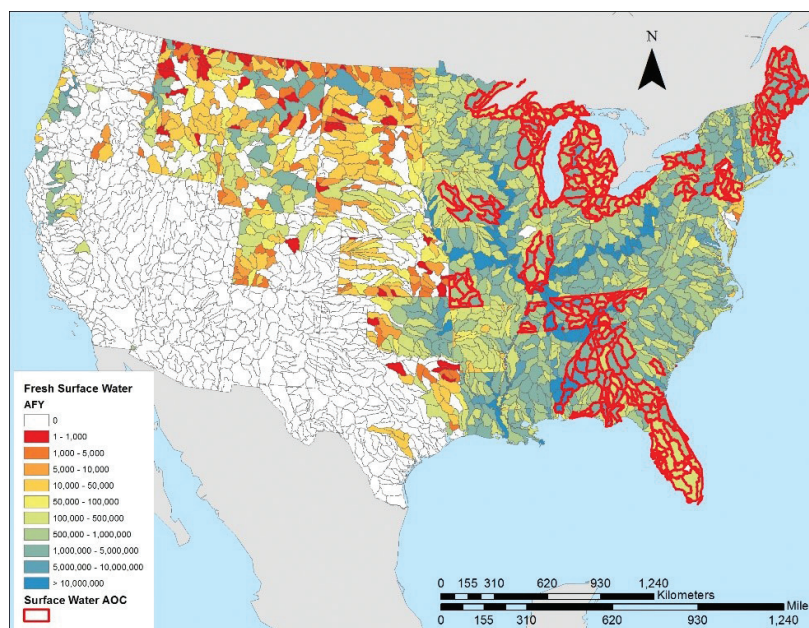

Fresh surface water availability mapped by 8-digit HUC watershed for the contiguous United States.

INCREASING WATER EFFICIENCY AND REUSE

Advanced Cooling Technologies, Inc.:

A Novel Steam Condenser with Loop Thermosyphons and Film-Forming Agents for Improved Heat Transfer Efficiency and Durability 14

Gas Technology Institute (GTI):

Enhanced Cooling Tower Technology for Power Plant Efficiency Increase and Operating Flexibility..... 15

Infinite Cooling, Inc.:

Water Recovery from Cooling Tower Plumes..... 16

Interphase Materials, Inc.:

Application of Heat Transfer Enhancement (HTE) System for Improved Efficiency of Power Plant Condensers 17

Massachusetts Institute of Technology:

Capillary-Driven Condensation for Heat Transfer Enhancement in Steam Power Plants 18

Nelumbo Inc.:

Enhancing Steam-Side Heat Transfer via Microdroplet Ejection using Inorganic Coatings..... 19

Oak Ridge National Laboratory (ORNL):

Enhanced Steam Condenser for Power Generation Applications..... 20

University of North Dakota Energy and Environmental Research Center (UNDEERC):

Wastewater Recycling Using a Hygroscopic Cooling System..... 21

Virginia Polytechnic Institute and State University:

Novel Patterned Surfaces for Improved Condenser Performance in Power Plants 22

A Novel Steam Condenser with Loop Thermosyphons and Film-Forming Agents for Improved Heat Transfer Efficiency and Durability

Performer	Advanced Cooling Technologies, Inc.
Award Number	FE0031657
Project Duration	10/01/2018 – 09/30/2021
Total Project Value	\$ 937,498
Technology Area	Plant Optimization Technologies

This project will develop a novel steam condenser to enhance heat transfer performance and increase the overall efficiency of coal-fired power plants. The loop thermosyphon uses a low boiling point refrigerant fluid to cool the steam through evaporation. The evaporated refrigerant is then passively transported to a cooling source. A film-forming agent will be injected into the steam and be deposited on the condensing surface, i.e., the outside surface of the evaporator section of the proposed thermosyphon. Such film-forming chemicals have been developed by General Electric and have demonstrated their capability to enhance the durability of the tubes because of improved corrosion resistance. The resultant films also make the surface hydrophobic, changing the condensation from filmwise to dropwise and removing its thermal resistance. Improved corrosion resistance will allow the use of low-cost tubing and structural materials such as carbon steel.

Benefits of the proposed loop thermosyphon/film-forming agent-based steam condenser include (1) passive and effective transport of the heat out of the process steam without auxiliary pumping system or electricity consumption, leading to a one percent increase in overall plant electrical conversion efficiency; (2) closed cooling loop system will require no maintenance or cleaning because it uses a refrigerant, thereby reducing downtime and maintenance costs; (3) strong enhancement of condensation heat transfer on the steam side (through dropwise condensation) and avoidance of issues related to mineral deposit, resulting in a 50 percent decrease in thermal resistance, and (4) enhancement of the durability of the condensing tubes due to the corrosion-inhibiting features of filming agents. Operating costs will be lower due to the absence of cooling water pump failures, water treatment chemicals, and required maintenance for a long-life loop thermosyphon tube.

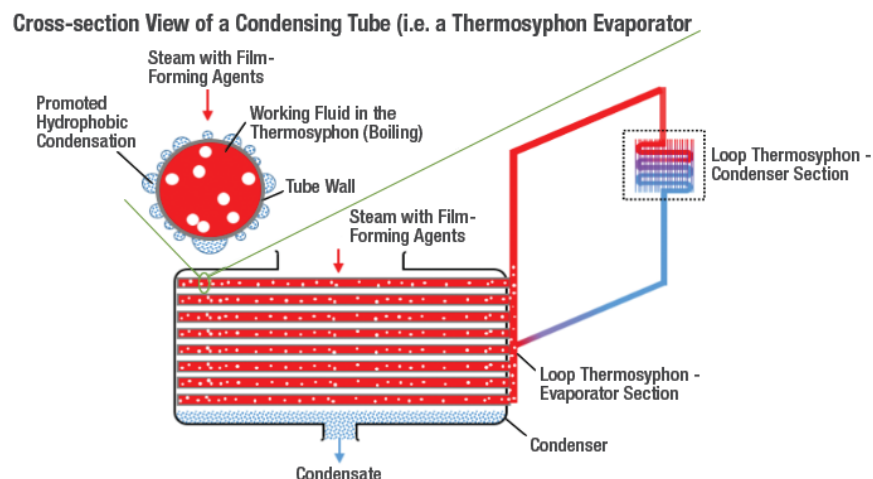

Proposed steam condenser coupled with a loop thermosyphon and film-forming agent.

Enhanced Cooling Tower Technology for Power Plant Efficiency Increase and Operating Flexibility

Performer	Gas Technology Institute (GTI)
Award Number	FE0031833
Project Duration	10/01/2019 – 09/30/2022
Total Project Value	\$ 1,537,798
Collaborators	Baltimore Aircoil Company; Illinois Institute of Technology; Worley Group Inc.
Technology Area	Plant Optimization Technologies

The objective of the project is to develop a technology that enhances flexibility and improves the efficiency of existing recirculating cooling towers by precooling and dehumidifying air prior to entering the cooling tower fill while controlling parameters of the air under cyclic and part-load operation. It is proposed to demonstrate and model a sub-dewpoint cooling tower technology (patent pending) that increases coal-fueled power plant operating performance under cyclic and part-load operation. The technology employs an innovative flow arrangement called a pressure dehumidifying system (PDHS) coupled with effective heat and mass transfer so that air is cooled and dehumidified prior to entering the cooling tower fill. The air cooling and dehumidification is accomplished by a near-atmospheric pressure regeneration technique and efficient heat exchange components with ultra-low energy requirements. The main components of the PDHS are an air heat exchanger, blower, heat-mass exchanger, and expander. The blower in the system slightly pressurizes the incoming air and increases the air dew point, thus making it easier to remove moisture from the air flow using the heat-mass exchanger. The expander is used to offset the power consumed by the blower, thus making this an ultra-low energy consumption system. Preheating the ambient air in the heat exchanger by using waste heat from the coal-fired boiler or other heat sources would allow deeper or optimized cooling of air and water in the cooling tower. Mixing the ambient air with flue gas from the coal-fired boiler or with exhaust air from the cooling tower would allow harvesting more water vapor and potentially eliminating makeup water requirements.

The proposed technology of the enhanced sub-dewpoint cooling tower requires no significant modification to existing cooling towers, requires no new materials, and uses available commercial hardware installed outside the cooling tower.

These features and the system's flexible operation reduce technical risk and improve the chances of early adoption. The enhanced cooling tower technology provides lower water temperatures, water harvesting from ambient air that directly reduces make-up water, and, with better cooling, higher power generation efficiency that reduces evaporative losses. It is also expected to break the paradigm of a cooled water temperature limit of 5 °F above the ambient wet bulb. Cooling the water below the ambient dewpoint temperatures and controlling the water temperature, depending on weather conditions, would increase plant efficiency under cycling and part-load operation. If successful, this technology will not only benefit the power industry but also many other industries including manufacturing plants, buildings, data centers, and other large facilities that also use cooling towers and cooling loops.

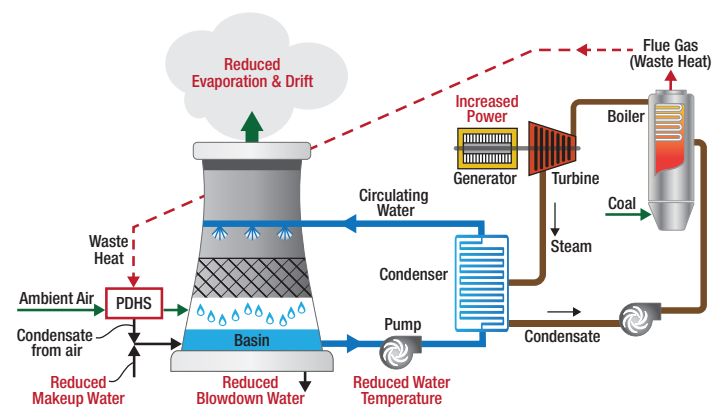

Implementation of sub-dew point cooling tower technology in a coal-fired plant: pressure dehumidifying system (PDHS).

Water Recovery from Cooling Tower Plumes

Performer	Infinite Cooling, Inc.
Award Number	FE0031828
Project Duration	10/01/2019 – 09/30/2022
Total Project Value	\$ 1,875,000
Technology Area	Plant Optimization Technologies

This project consists of the study of plume formation and collection on mechanical (induced) draft cooling towers, partly in a high-fidelity controlled environment and partly on a full-scale industrial cooling tower. It will start by building the needed laboratory setup and installing various sensors on the lab cooling tower. At the same time a computational fluid dynamics (CFD) model will be implemented to get precise full-scale plume models. Using the insights into power-plant plume characteristics, Infinite Cooling, Inc. will iterate on and experimentally test electrodes and collectors, which make up modular panels, on the lab cooling tower. What has been learned from the full-scale plume modeling and sensor data analysis will then be applied to develop a design model to build the optimal collection apparatus for given working conditions of the full-scale industrial cooling tower. Portions of this design will be prototyped and tested on the lab cooling tower to evaluate collection efficiency. The result will be a ready-to-deploy design for a high-throughput water collector for cooling tower plumes on an industrial cooling tower. Once the design is complete, manufacturing of the modular collection panels and structure will commence at the pilot/field testing site. Here, performance of the collection device will be measured on an actual industrial cooling tower. Infinite Cooling will measure the efficiency of the design and sample the water that is collected, analyze its properties, and determine the presence of possible contaminants.

At the end of the project, lab cooling tower plume properties will be understood and the knowledge gained will be used to optimize the design, material, and electrical properties of the collection device; quantify the yield by flow rate

and water quality; and finally, push collection efficiency further by advanced collection enhancement approaches. If successful, the technology that is developed could lead to significant water savings and improve water quality with minimal energy cost. Existing towers can be easily retrofitted with the technology, leading to a significant reduction in water usage in cooling towers as well as a reduction in chemical use for water treatment in coal plants.

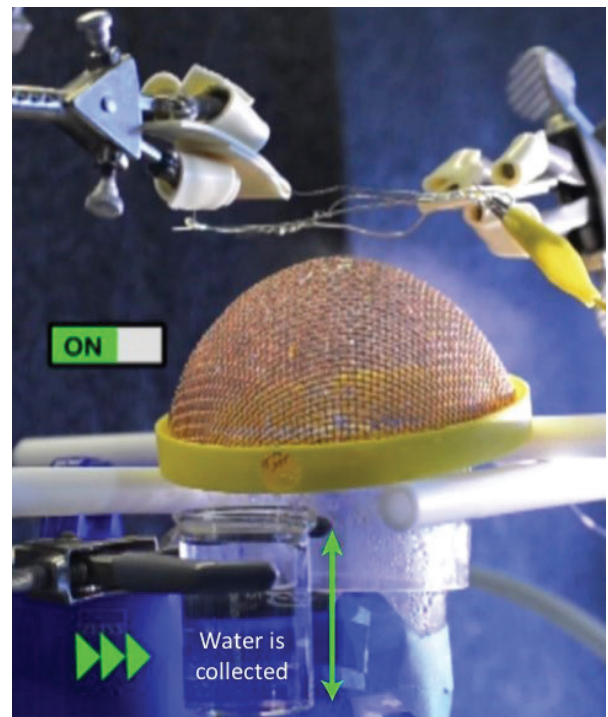

Lab-scale prototype of plume collection mesh.

Application of Heat Transfer Enhancement (HTE) System for Improved Efficiency of Power Plant Condensers

Performer	Interphase Materials, Inc.
Award Number	FE0031561
Project Duration	02/01/2018 – 01/31/2021
Total Project Value	\$ 961,915
Technology Area	Plant Optimization Technologies

NETL is partnering with Interphase Materials, Inc. to determine the condenser efficiency improvements as well as the reduction of continuous-feed water treatment that coal-fired plants could realize by utilizing Interphase's heat transfer enhancement technology (HTE system). Previous lab-scale work has demonstrated that the HTE system can inhibit biofouling, microbiologically induced corrosion, and scale buildup as well as improve the baseline heat transfer efficiency of cooling. By applying the HTE system first to field test rigs at the Longview power plant (Maidsville, WV) and subsequently to the condenser at the plant, Interphase and Longview will collect field data on the HTE system's potential to increase heat transfer efficiency in the condenser cooling systems of coal-fired power plants.

If the anti-biofouling and heat transfer enhancement properties of the HTE system are shown to be effective on in-service power plant condensers, there is an opportunity to lower the heat rate of the existing U.S. coal power generating fleet. Fouling prevention could result in a reduction of water treatment chemical volumes, which would help power plants meet requirements of the Environmental Protection Agency Clean Water Act. Reducing fouling will also reduce cleaning frequency and maintenance costs, increase hardware lifecycles, and help power plants maintain efficient long-term operation.

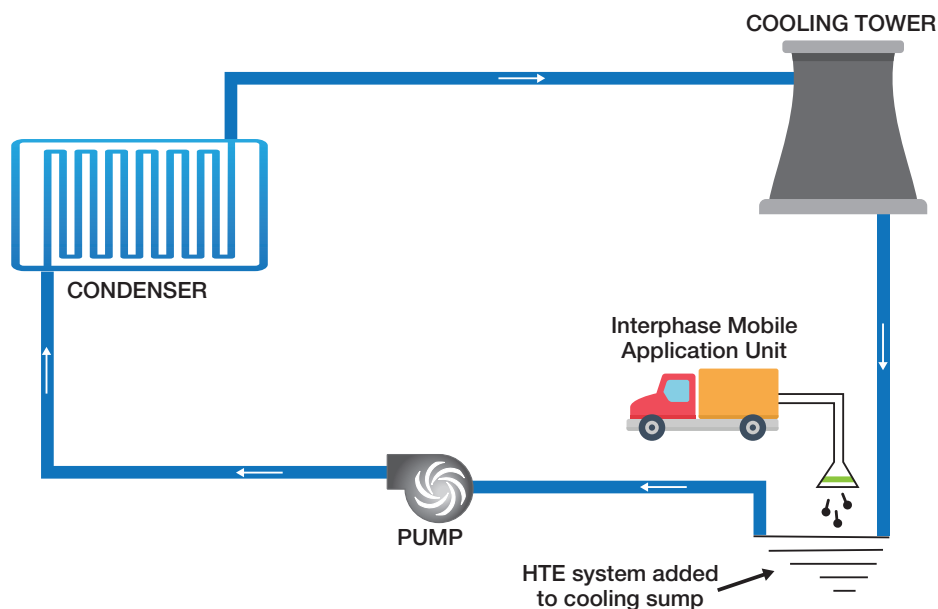

Diagram of HTE application to Longview cooling system.

Capillary-Driven Condensation for Heat Transfer Enhancement in Steam Power Plants

Performer	Massachusetts Institute of Technology
Award Number	FE0031677
Project Duration	10/01/2018 – 09/30/2021
Total Project Value	\$ 937,989
Technology Area	Plant Optimization Technologies

The Massachusetts Institute of Technology (MIT) will develop a robust new approach to enhance condensation heat transfer for steam power plants via capillary-driven condensation. To achieve this goal, MIT will (1) design and develop various wicking structures and porous hydrophobic membranes to reduce the thermal resistance and enhance capillary driven flow; (2) experimentally investigate capillary-driven condensation on flat and tube substrates, experimentally characterize the condensation heat transfer performance, and compare it with traditional film-wise condensation on various samples; (3) optimize the capillary-driven condensation structure with model development, develop a physics-based model to predict and optimize condensation heat transfer, and experimentally validate the results; (4) incorporate capillary-driven condensation structures to demonstrate scaled-up proof-of-concept operation, and (5) with Heat Transfer Research Inc. support,

perform experiments on tube bundles under relevant industrial conditions.

If successful, this approach will significantly improve power production while decreasing the amount of water needed for condensation in thermoelectric power plants. Also, a new robust condenser design for steam power plants with greater than five times enhancement in heat transfer coefficients compared to conventional film-wise condensation will be demonstrated. Due to the improved heat transfer coefficient of condensation, the steam condensation temperature and the turbine back-pressure can be reduced by up to 4 degrees Celsius and 0.7 kilopascals, respectively. Consequently, the overall heat rate of a typical power plant can be expected to be reduced by 1.5 percent, leading to an additional 13.80 megawatts (MW) of generated power from a 950 MW plant, and commensurate savings in water withdrawal and usage.

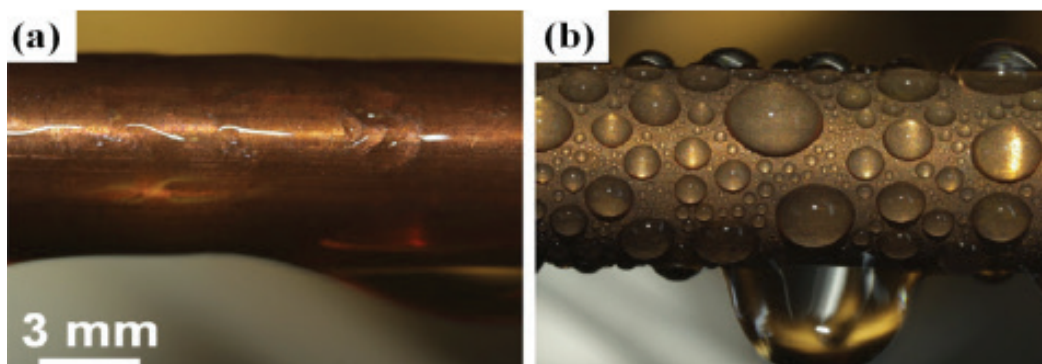

(a) Filmwise condensation of water on a bare copper condenser tube and
(b) dropwise condensation of water on a copper tube functionalized with a monolayer hydrophobic coating.

Enhancing Steam-Side Heat Transfer via Microdroplet Ejection using Inorganic Coatings

Performer	Nelumbo Inc.	Lawrence Berkeley National Laboratory (LBNL)
Award Number	FE0031675	FWP-FP6315
Project Duration	10/01/2018 – 09/30/2021	10/01/2018 – 09/30/2021
Total Project Value	\$ 704,747	\$ 235,000
Total Project Value (All)	\$ 939,747	
Technology Area	Plant Optimization Technologies	

The objective of this project is to develop and test droplet rejection coatings [previously optimized for aluminum (Al) and copper (Cu)] on stainless steel and Cu-nickel (Ni) alloys commonly found in coal power plant steam condensers. Specific tasks include (1) modifying the specific process and chemistries of the coating to steam condenser-relevant materials, (2) testing the heat transfer and durability coatings under a variety of conditions on a laboratory-scale test condenser, and (3) using a combination of microdroplet surface dynamics models and empirical results to develop a macroscale model to deduce the effect of droplet rejection surface treatments on condenser performance at full scale and across a variety of operating conditions. The project will adapt processes and compositions of Nelumbo coatings currently used in air conditioning and refrigeration to materials used in steam condensers. Nelumbo will focus on two alloys—stainless steel 304 and $\text{Cu}_{90}\text{Ni}_{10}$ —due to their widespread use.

The results obtained from this project will adapt droplet ejection coatings to a shell-side heat exchanger under steam condenser conditions. Improved performance will be validated in the laboratory and additional data regarding tube-side potential application for these materials will be generated. Completion of test articles of the coated material under standardized tests for anti-fouling and anti-corrosion will be used to verify coating reliability and durability in a steam condenser environment. Additional benefits include reduced water usage in a once-through steam condenser by up to 39 percent, saving 78,000 gallons per minute and up to \$6 million per year in operating a 500 MW turbine.

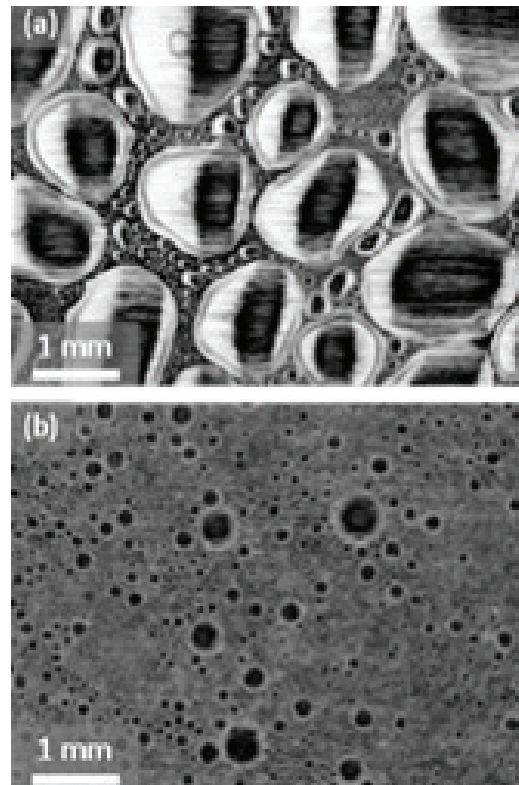

Condensation on (a) uncoated and (b) coated surface with Nelumbo coating.

Enhanced Steam Condenser for Power Generation Applications

Performer	Oak Ridge National Laboratory (ORNL)
Award Number	TCF-19-17770
Project Duration	10/01/2019 – 09/30/2020
Total Project Value	\$ 335,000
Technology Area	Plant Optimization Technologies

Condensation is an important part of several energy conversion processes. Rankine cycle-based power generation system performance relies heavily on condenser performance. Such devices are oftentimes shell-and-tube type heat exchangers where the steam condenses on the shell side by transferring heat to the cooling fluid passing through the tubes. To maximize performance of the condenser, it is operated in drop-wise condensation mode, which can lead to an order of magnitude higher heat transfer rate compared to film-wise condensation. While there is a range of processes where surface morphology can be modified to increase the contact angle and to make the surface hydrophobic, which promotes the dropwise condensation, there have been rare developments where the technology is scaled and durable. Hydrophobic coatings have been used with limited success because they are not durable when exposed to operating conditions observed in the condenser of a typical fossil fuel or nuclear power plant.

ORNL is proposing a scalable and durable solution that involves altering the surface morphology by three unique and equally effective processes, including the acid etching

process, laser ablation of surfaces, and formation of an oxide layer by exposure to oxygen-enhanced flame. The goal is to demonstrate the durability and scalability of the technology so that appropriate vendors can be convinced to further develop and commercialize the technology.

Preliminary development has shown that these three techniques can provide surfaces with extended life (comparable to useful life of the equipment) and does not require regular maintenance due to their self-cleaning nature which resists the accumulation of deposits. As such, the condenser can sustain its performance even under extreme conditions. This concept is highly aligned with the Technology Commercialization Fund objectives because it will advance a highly cost-effective and scalable novel technology for fossil energy-based power generation. Based on preliminary assessment, the proposed concept can lead to at least 150 percent improvement in heat transfer coefficient by promoting dropwise condensation and as such can reduce the size of the device by at least 30 percent compared to the state-of-the-art technology. In addition, equipment maintenance can be reduced substantially.



Film-wise vs. drop-wise condensation.

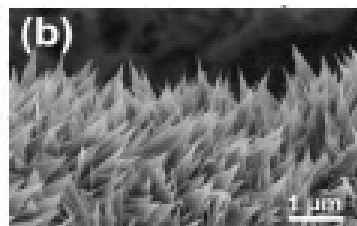

Microstructure of enhanced surface (etched by acidic solution)

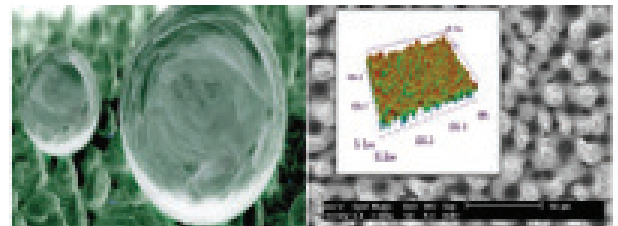

Surface enhancement by laser ablation.

Wastewater Recycling Using a Hygroscopic Cooling System

Performer	University of North Dakota Energy and Environmental Research Center (UNDEERC)
Award Number	FE0031810
Project Duration	10/01/2019 – 09/30/2022
Total Project Value	\$ 820,675
Collaborator	Baltimore Air Coil
Technology Area	Plant Optimization Technologies

University of North Dakota (Grand Forks, ND) will test the feasibility of using the Energy & Environmental Research Center's hygroscopic cooling technology to eliminate power plant wastewater by recycling the water fraction to augment the plant's cooling load and collecting the remainder as a solid by-product for reuse or disposal. The team will survey wastewater sources at a candidate host site power plant and collect samples for analysis and a laboratory evaluation of forced precipitation. The parameters relevant to makeup water addition will be studied and optimal design criteria will be identified for a selected targeted wastewater stream. An initial review of potential hazardous materials within the stream or resulting from treatment will also be conducted. Design criteria from the laboratory evaluation will be used to inform the design of a small pilot system capable of evaporation of the water fraction of a real wastewater feed, sustainable forced precipitation of dissolved contaminants in the wastewater, and recovery of the solid by-products. Procurement and fabrication tasks will be divided among the team members to produce the small pilot system. The small pilot system will be used to evaluate the elimination of wastewater obtained from a host site power plant. Heat source temperatures will be consistent with those typical of the plant's condenser cooling water circuit. The test duration will be sufficient to determine the material balance of the wastewater recycling process and to produce a sufficient quantity of by-product solids for subsequent disposal/reuse analysis. A summary techno-economic analysis will be conducted based on findings from the small pilot system design and testing results. Estimates will be made for equipment capital, plant integration, and system

operating costs. Cost or revenue associated with the by-product material will be evaluated, as well as changes to other plant expenses, e.g., from a reduction in freshwater acquisition and treatment.

A key benefit of this technology is that it improves the plant's overall water-use efficiency while allowing it to conform with zero-liquid-discharge requirements.

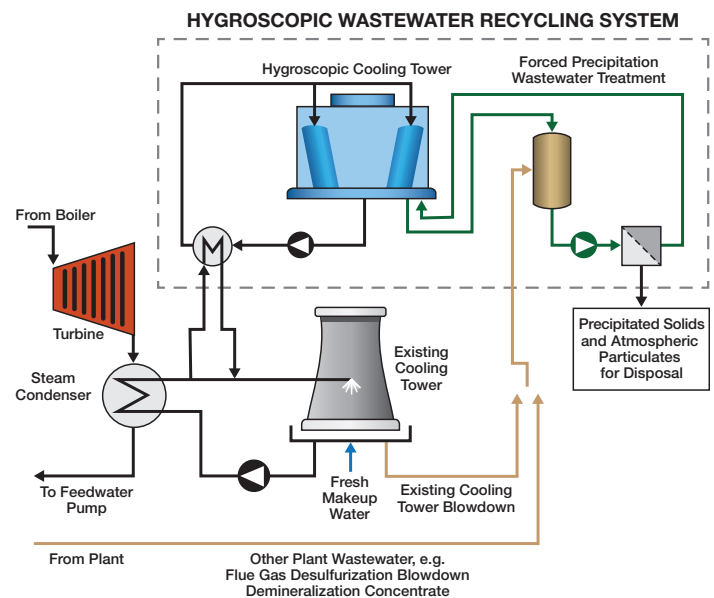

High-level schematic system applied at a full-scale thermoelectric power plant.

Novel Patterned Surfaces for Improved Condenser Performance in Power Plants

Performer	Virginia Polytechnic Institute and State University
Award Number	FE0031556
Project Duration	12/15/2017 – 12/14/2021
Total Project Value	\$ 938,470
Technology Area	Plant Optimization Technologies

NETL is partnering with Virginia Polytechnic Institute and State University to improve thermoelectric power plant performance through engineered superhydrophobic/slippy liquid infused porous surfaces (SLIPS) for condenser tube designs fabricated by a patented two-step electrodeposition technique. Electrodeposition is a widely-used industrial process that is applicable to a variety of shapes, materials, and sizes. The project will demonstrate and characterize a variety of SLIPS coatings based on copper, nickel, copper/nickel, zinc, tungstite, and other materials commonly used on condenser tube surfaces—namely, copper, copper/nickel, stainless steel, and titanium alloys—through a facile and cost-effective electrodeposition

process. The goal is to demonstrate overall condenser heat exchanger effectiveness that is at least 50 percent higher than that of current systems while reducing condenser pressure and improving power plant efficiency.

The research conducted will broaden both fundamental and applied scientific knowledge in the field of transport phenomena using SLIPS surfaces and the robust, scalable fabrication process of the structures. Project success could advance novel, industrially scalable, and low-cost fabrication of durable SLIPS coatings that will lead to improved plant efficiency and performance and thereby to reduced carbon dioxide emissions.

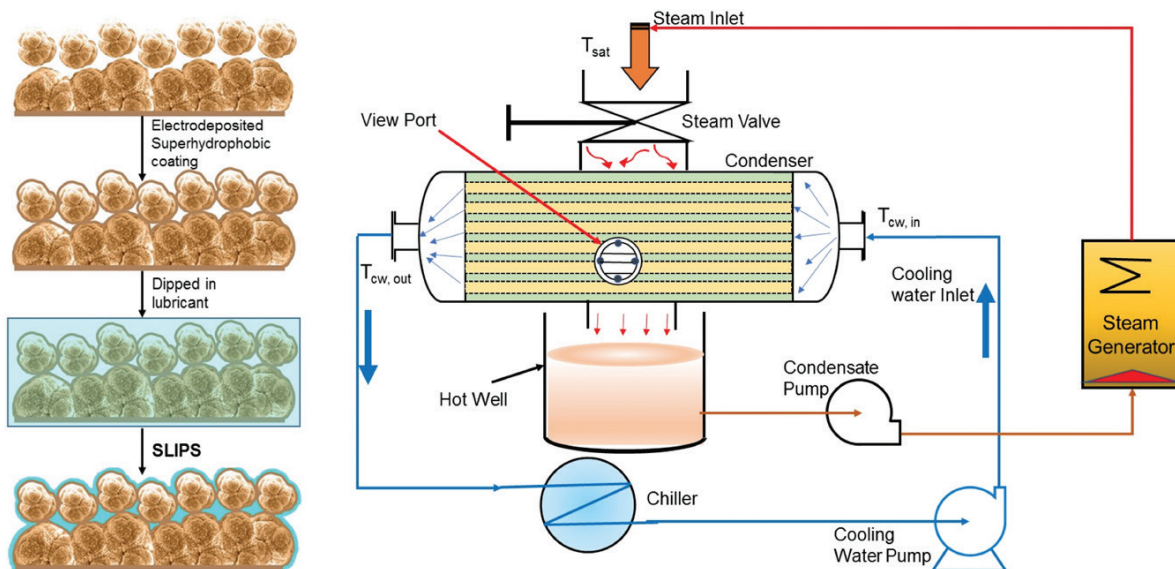

Proposed SLIPS coating to enhance heat transfer and reduce drag on condenser surfaces.

TREATING ALTERNATIVE SOURCES OF WATER

Electric Power Research Institute, Inc.:

Demonstrations of Holistic, Lower Cost/Energy Effluent Water Management Approaches for Coal-Fired Energy Plants 24

Gas Technology Institute (GTI):

Co-Generation Wastewater Treatment at Coal-Fired Energy Plants 25

Montrose Water and Sustainability Services, Inc.:

Flue-Gas Desulfurization Effluent Management Using an Innovative Low-Energy Biosorption Treatment System to Remove Key Contaminants 26

National Energy Technology Laboratory (NETL):

Water Management for Power Systems: Concentrating Wastewater Effluent Streams – Task 4..... 27

National Energy Technology Laboratory (NETL):

Water Management for Power Systems: Guiding R&D for Treatment of Coal Power Plant Effluent Streams – Task 2..... 28

National Energy Technology Laboratory (NETL):

Water Management for Power Systems: Selective Removal of Heavy Metals from Effluent Streams – Task 3..... 29

SRI International:

Development of a High Efficient Membrane-Based Wastewater Management System for Thermal Power Plants 30

University of California - Los Angeles:

Applying Anodic Stripping Voltammetry to Complex Wastewater Streams for Rapid Metal Detection..... 31

University of Illinois at Urbana-Champaign:

Energy Efficient Waste Heat Coupled Forward Osmosis for Effluent Water Management at Coal-Fired Power Plants 32

University of Kentucky Research Foundation:

Intensified Flue Gas Desulfurization Water Treatment for Reuse, Solidification, and Discharge 33

West Virginia State University:

Dev. Cost-Effective Biological Removal Technology for Selenium & Nitrate from Flue Gas Desulfurization Wastewater from Existing Power Generating Facility..... 34

West Virginia University Research Corporation:

Produced Water and Waste Heat-Aided Blowdown Water Treatment: Using Chemical and Energy Synergisms for Value Creation 35

Demonstrations of Holistic, Lower Cost/Energy Effluent Water Management Approaches for Coal-Fired Energy Plants

Performer	Electric Power Research Institute, Inc.
Award Number	FE0031678
Project Duration	10/01/2018 – 09/30/2020
Total Project Value	\$ 922,989
Collaborators	Golder Associates, Inc.; Saltworks Environmental USA, Inc.
Technology Area	Plant Optimization Technologies

The objective of this project is to evaluate a set of effluent water management technologies and strategies that yield lower-cost clean water and reduced energy consumption compared to conventional systems used in coal-fired energy plants, and additionally generate salts and solids byproducts that can be reused or disposed as non-hazardous waste materials in landfills. The approach is holistic, addressing both water treatment and byproducts. The goals of the project are to (1) develop and use a statistical-based water mass balance model to identify opportunities for reducing water consumption and meeting discharge treatment requirements; (2) demonstrate at pilot scale a potentially highly effective, lower-cost energy technology for treating

flue gas desulfurization (FGD) discharges at the Water Research Center (WRC); and (3) develop and test the encapsulation for safe disposal of solid byproducts of the wastewater treatment process that have no productive use.

The benefit of this project will be demonstration at pilot scale of a flue gas desulfurization discharge treatment system for significant cost/energy savings, along with approaches to make unusable byproducts safer and cheaper to dispose as non-hazardous materials. The software models and associated guidelines developed in the project will help energy plants see wastewater treatment and byproduct encapsulation as components of a holistic approach to water management.

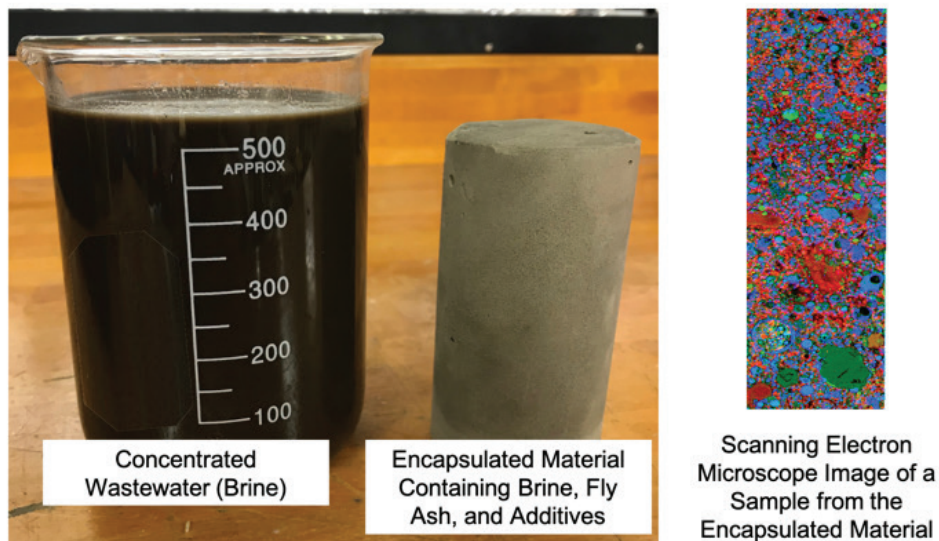

Concentrated wastewater combined with fly ash and additives to form an encapsulated material.

Co-Generation Wastewater Treatment at Coal-Fired Energy Plants

Performer	Gas Technology Institute (GTI)
Award Number	FE0031669
Project Duration	10/01/2018 – 09/30/2020
Total Project Value	\$ 936,000
Technology Area	Plant Optimization Technologies

The objective of this project is to show that Gas Technology Institute's FGD wastewater clean-up technology is effective at removing critical pollutants of concern (CPoC), can operate at low cost, offset some treatment costs, and is compact for retrofit applications. This technology uses Direct Contact Steam Generation (DCSG), a process developed for oil sands production over the last eight years. It is proposed to apply the DCSG technology for water cleanup, specifically for the FGD wastewater treatment at coal-fired energy plants, while co-generating power to offset treatment costs. The goal is to meet or exceed the CPoC emission requirements in the near future and to reuse the water in this effluent stream. This process was successfully demonstrated for oil sands produced water, and extending this technology for FGD wastewater holds great promise.

The FGD wastewater is vaporized in a DCSG unit (primarily burning natural gas) to produce steam. The gaseous steam is filtered to remove pollutants captured as solids. The CPoC are captured in a dry filter cake and disposed of in an appropriate landfill (an alternative approach that will be evaluated is to clean saturated steam in a steam separator and send the concentrated brine to a disposal well). The clean steam stream is then expanded through a turbine to co-generate power and offset the operating and capital recovery costs. Treated steam is cooled via incoming wastewater or a cooling tower to produce treated water (quantity depends on system configuration). The treated water will be released or re-used within the power generation facility to reduce freshwater requirements.

Successful development and application of this technology will result in improved wastewater management and reuse and a lower cost of electricity. The incumbent technology, physical-chemical and biological treatment systems, provides no offsetting revenue stream and adds significant costs to the overall process.

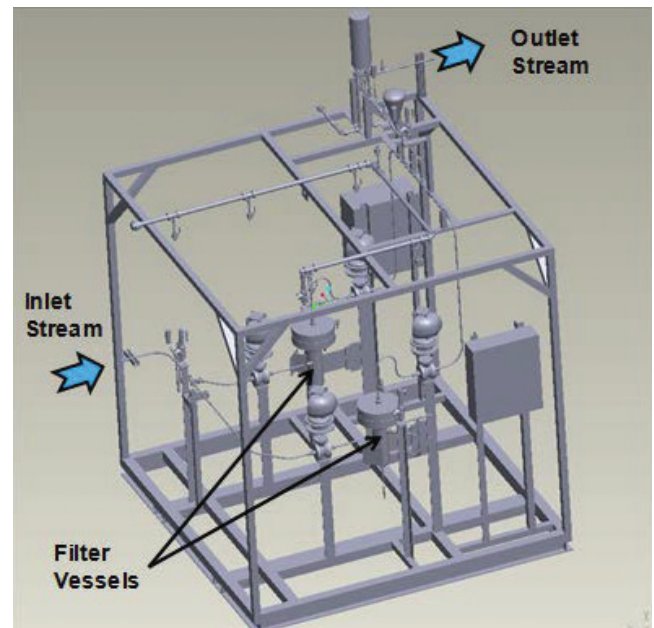

Subscale (1/4 MWth) surface steam generator (produced water testing) skid.

Flue-Gas Desulfurization Effluent Management Using an Innovative Low-Energy Biosorption Treatment System to Remove Key Contaminants

Performer	Montrose Water and Sustainability Services, Inc.
Award Number	FE0031676
Project Duration	10/01/2018 – 09/30/2021
Total Project Value	\$ 941,206
Technology Area	Plant Optimization Technologies

The goal of this project is to demonstrate an innovative, energy-efficient water treatment system for FGD wastewater treatment to meet the Effluent Limitations Guidelines and Standards for the Steam Electric Power Generating Point Source Category (ELGs). The proposed treatment system uses hybrid biosorption, which is an adsorption process enhanced by biological activity to remove selenium, arsenic, nitrate, and potentially other contaminants from FGD wastewater. The objectives are to (1) evaluate a biosorption treatment system at the Water Research Center at Plant Bowen; (2) demonstrate both energy and water savings associated with the proposed innovative water treatment process; (3) using available published data, compare energy and water savings with alternative technologies that

are typically used to remove the target contaminants, and (4) provide long-term management of the FGD wastewater challenge that plagues coal-fired power plants by offering a low-energy, high water-efficiency water treatment system that also significantly decreases waste byproducts by utilizing available waste heat.

Treating FGD effluents at the point of generation can provide clean water source for potential beneficial on-site reuse at power generating facilities. The energy-efficient water treatment system proposed in this project will help reduce energy demand associated with water treatment in power generating facilities, but can also be used in the industrial, agricultural, and municipal sectors.

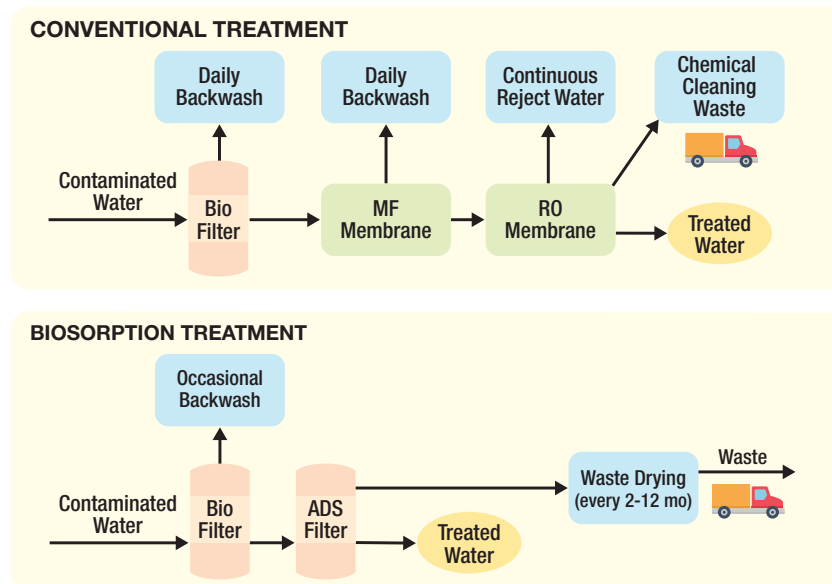

Comparison of conventional process and proposed treatment system.

Water Management for Power Systems: Concentrating Wastewater Effluent Streams – Task 4

Performer	National Energy Technology Laboratory (NETL)
Award Number	FWP-1022428 Task 4
Project Duration	04/01/2018 – 03/31/2020
Total Project Value	\$ 278,000
Technology Area	Plant Optimization Technologies

The objective of this research is to experimentally demonstrate and numerically simulate a novel membrane process for concentrating effluent streams. Effluent waste streams from coal power plants contain heavy metal contaminants and hence cannot be discharged to local waterways, and treatment of these effluent streams is currently very expensive. While there are cost-effective treatment processes for low salinity water, such as reverse osmosis, such processes wind up generating a medium salinity brine that must be further concentrated. The Environmental Protection Agency estimates that the compliance costs are \$480 million for the Final Rule limiting effluent streams at coal power plants, with estimated benefits of between \$451 and \$566 million. Hence, to increase net benefits, it is crucial to develop innovative technologies that can lower the cost of treating these heavy metal effluent streams at coal power plants.

One option for treating these effluent streams is called zero liquid discharge (ZLD), which effectively concentrates the dissolved ionic species while separating out fresh water. Currently, ZLD is an expensive option for treating these effluent streams because of the high energy and capital cost associated with the brine concentration step in the ZLD process. As such, this task will demonstrate advanced technologies that can concentrate effluent streams to high concentrate while reducing energy consumption.

This brine concentration research has the potential to reduce capital cost and electricity consumption for treating and concentrating high salinity brines generated at coal-fired power plants by at least 50 percent compared to commercially available, non-membrane technologies, such as mechanical vapor recompression.

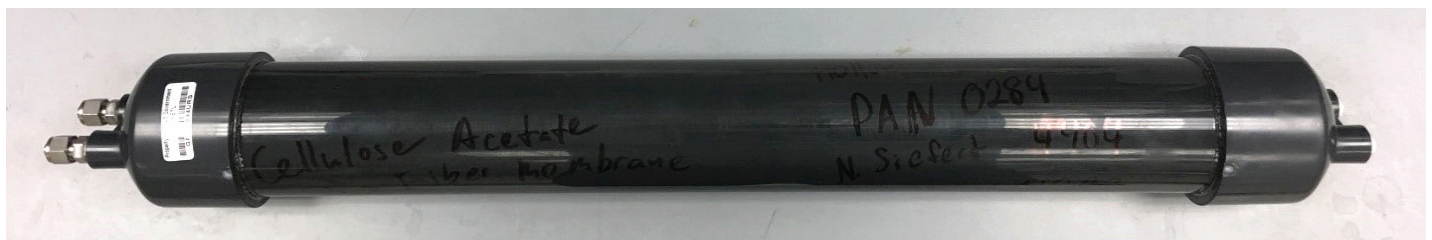

Hollow fiber membranes for scale-up testing of osmotically assisted reverse osmosis process.

Water Management for Power Systems: Guiding R&D for Treatment of Coal Power Plant Effluent Streams – Task 2

Performer	National Energy Technology Laboratory (NETL)
Award Number	FWP-1022428 Task 2
Project Duration	04/01/2018 – 03/31/2020
Total Project Value	\$ 820,000
Technology Area	Plant Optimization Technologies

The objective of this effort is to (1) evaluate effluent water-related issues at both existing and new coal power plants and (2) use the results obtained from techno-economic studies to help guide research in this area. Treatment of effluent streams at coal-fired power plants is currently attracting significant inquiry and interest due to recent Environmental Protection Agency (EPA) regulations. Because discharge requirements for new and existing coal plants are different, treatment approaches of their effluent streams will be different. This task will explore how the zero-liquid discharge (ZLD) systems required of new coal plants may change as a function of certain constituents in the coal, such as chlorine. Likewise, it is not clear if the wastewater/effluent treatment technology of choice for existing coal plants is applicable to coal plants burning low-rank coals (such as subbituminous or lignite) or how the technology will be required to perform. This task will also explore those issues as they relate to wastewater treatment systems at existing plants.

Technical information obtained from this task will identify water related research and development needs and provide management knowledge of current/future regulations and possible technologies to meet these regulations. The benefit to existing coal units will be greater knowledge of how heavy metals are divided amongst the various effluent streams and how this information could inform the EPA's anticipated revision of the wet flue gas desulfurization wastewater portion of the effluent limitation guideline rule. In addition, the ZLD technologies that are being evaluated for new coal power plants may eventually be required for existing units, since environmental standards typically only become more stringent over time. Understanding current and future water issues related to power plants is critical to inform program direction, goals, and research.

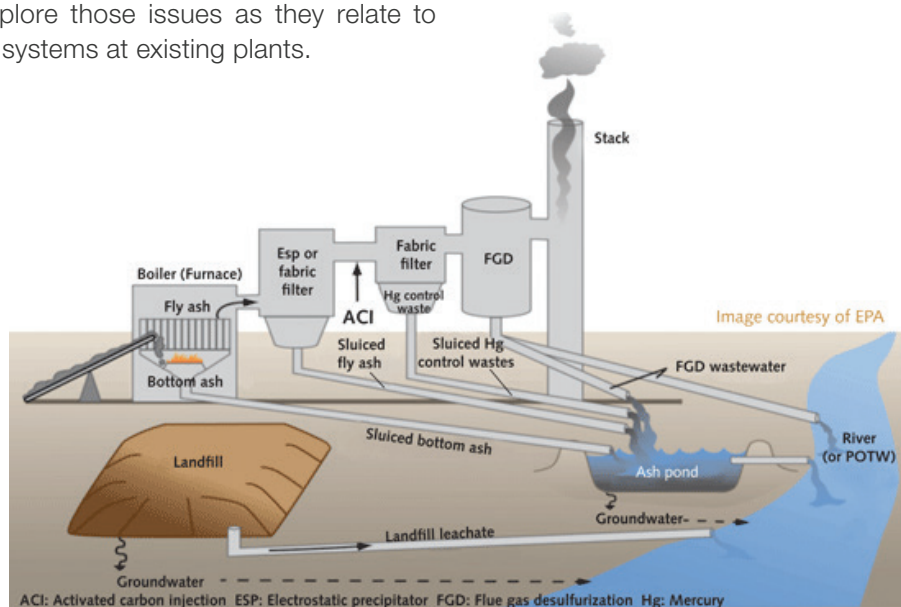

Coal-fired power plant.

Water Management for Power Systems: Selective Removal of Heavy Metals from Effluent Streams – Task 3

Performer	National Energy Technology Laboratory (NETL)
Award Number	FWP-1022428 Task 3
Project Duration	01/01/2017 – 03/31/2020
Total Project Value	\$ 1,130,000
Technology Area	Plant Optimization Technologies

The objective of this effort is to develop basic immobilized amine sorbent (BIAS) materials for the selective removal of heavy metals from industrial effluent, with focus on those effluent streams that are generated during coal combustion. Previous work on related BIAS sorbents shows that it is feasible to capture metals from complex mixtures with selectivity using this technology. Challenges with the flue gas desulfurization (FGD) system are centered upon the chemical form in which the metals persist in the FGD water, as opposed to feed sources that have been studied. NETL will expand on previous work to develop a sorbent material that can reduce both the regulated oxy-anionic heavy metals as well as the regulated cationic metals to, at a minimum, the permissible discharge levels by using a flow-based treatment method. The effort will include fabrication

of stabilized amine co-polymers on high surface area silica particles, screening for metal uptake, capacity testing, and treatment of authentic coal effluent water samples. In all phases of the work, detailed characterization of the BIAS materials, the feed solutions, and eluent solutions will be conducted. The target material will be designed to support effluent water treatment in a flow-through application with a low pressure drop across the sorbent bed. For this task, FGD water will be used as a target matrix for evaluating sorbent performance.

The technology developed in this project has the potential to reduce the cost of treating FGD or other effluent treatments by 50 percent compared to commercially available zero liquid discharge or chemical/biological treatment options.

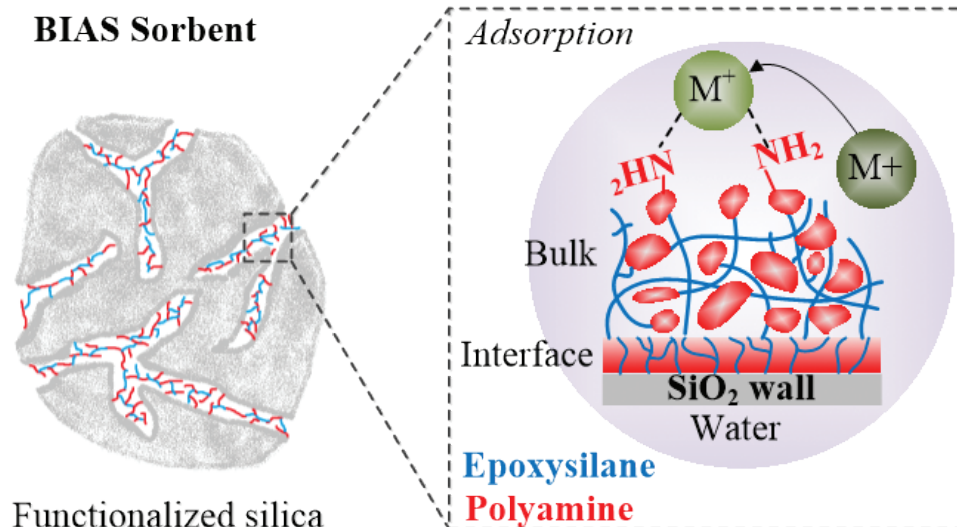

New research into novel chemical treatment options.

Development of a High Efficient Membrane-Based Wastewater Management System for Thermal Power Plants

Performer	SRI International
Award Number	FE0031552
Project Duration	12/19/2017 – 12/31/2020
Total Project Value	\$ 799,949
Collaborator	Enerfex, Inc.
Technology Area	Plant Optimization Technologies

The main goal of the proposed research is to develop innovative effluent water management practices at coal-fired energy plants. In particular, researchers plan to use SRI-based polybenzimidazole (PBI) hollow-fiber membrane (HFM) technology to remove selenium from flue gas desulfurization (FGD) wastewater below the effluent discharge limits (less than 5 parts per billion). The PBI membranes are resistant to fouling and can be operated under environments that are substantially harsher than those tolerated by commercially available membranes. The fouling resistance of the PBI-HFM based separation system under simulated FGD water discharge conditions will be tested.

The technology developed will allow the removal of toxic material in the FGD blowdown and other wastewater from the plant and provide an opportunity to develop methods for reducing water use within the plant and thereby reducing freshwater withdrawals. Success of this project will result in development of a power plant effluent control system that can remove the hazardous compounds and also recover and reuse the water to reduce freshwater withdrawal. In addition, energy use in effluent control systems in thermal power stations will be greatly reduced.

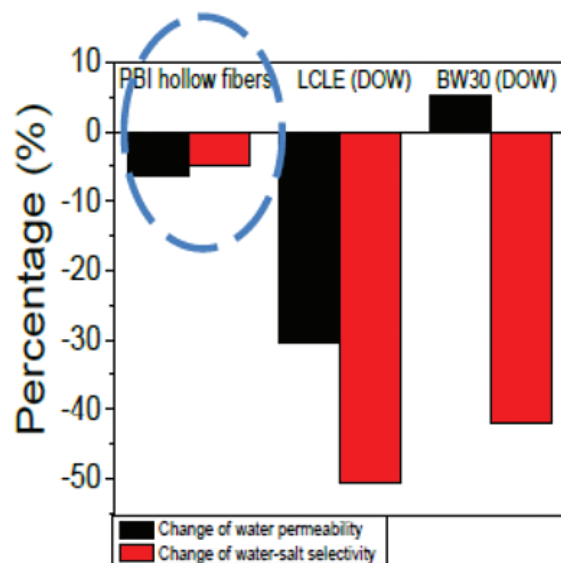

Demonstration of chlorine stability of PBI HFM compared to commercial membranes.

Applying Anodic Stripping Voltammetry to Complex Wastewater Streams for Rapid Metal Detection

Performer	University of California - Los Angeles
Award Number	FE0030456
Project Duration	08/01/2017 – 07/31/2021
Total Project Value	\$ 400,000
Collaborator	University of California, Riverside
Technology Area	University Training and Research

This project's objective is to develop a lab-on-a-chip (LOC) electrochemical sensor capable of accurately measuring heavy metal concentrations, including lead (Pb), cadmium (Cd), and arsenic (As), in complex aqueous streams such as municipal wastewater. The sensor technology relies on anodic stripping voltammetry (ASV), which has been demonstrated to detect extremely low (sub parts-per-million) concentrations of these metals. The technology will be capable of autonomously conducting metal measurements and report the findings remotely via cellular technology. Furthermore, using open-source hardware and software tools, the project team will construct sensor technology that operates with minimal human intervention and is capable of autonomously performing all of the pre-treatment steps needed to perform metal measurement activities. To accomplish this objective, the project team will concentrate on characterizing metal speciation in wastewater, develop

appropriate pre-treatment methods that will allow analysis of this complex matrix on an LOC device, fabricate a range of electrodes specifically tailored to enhance the detection of the target metals, and finally, construct and test an autonomous LOC device that incorporates the pre-treatment steps and specialized electrodes for the detection of heavy metals in wastewater.

All pre-treatment steps will be integrated into the fully automated LOC device, which will conduct the metal analysis without the need for human intervention beyond periodically re-filling reagent reservoirs. Current heavy metal measuring methods are time-consuming and rely on grab sampling and expensive analytical instruments. Thus, the proposed technology would decrease costs and increase the frequency of measurements, enabling heavy metal contamination to be detected in near real-time.

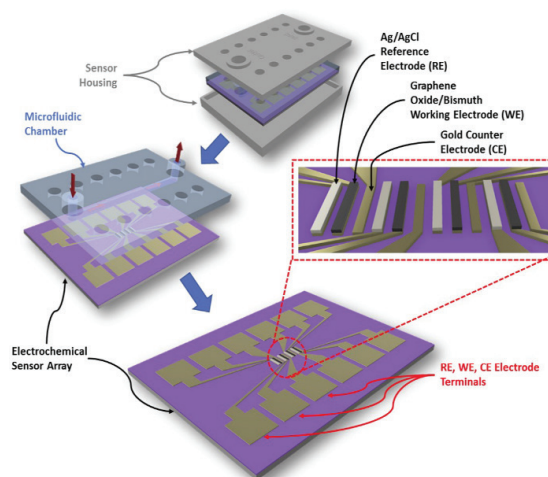

Schematic of electrochemical sensor arrays microanalyzer system.

Energy Efficient Waste Heat Coupled Forward Osmosis for Effluent Water Management at Coal-Fired Power Plants

Performer	University of Illinois at Urbana-Champaign
Award Number	FE0031551
Project Duration	12/19/2017 – 12/31/2020
Total Project Value	\$ 929,617
Collaborator	Trimeric Corporation
Technology Area	Plant Optimization Technologies

This project will evaluate a transformational low energy (less than 200 kilojoules/kilogram water) waste heat coupled forward osmosis (FO) based water treatment system (the Aquapod®), adapted to meet the complex and unique environment of a power plant, to manage effluents, meet cooling water demands, and achieve water conservation. The target is to enable recovery of at least 50 percent of the water from highly degraded water sources without extensive pretreatment in a cost effective manner.

The use of the Aquapod® FO process can double to quadruple the amount of water recovery from power plant effluents per unit of input energy compared to the current state of the art. It is also an intrinsically safe process, unlike the current state of the art, which utilizes gaseous ammonia. Project outcomes will enable the early-stage evaluation of a transformational water treatment system adapted to the power plant environment. A partner utility is engaged early in the technology development to assure that results would be applicable to large-scale coal-fired power plants.

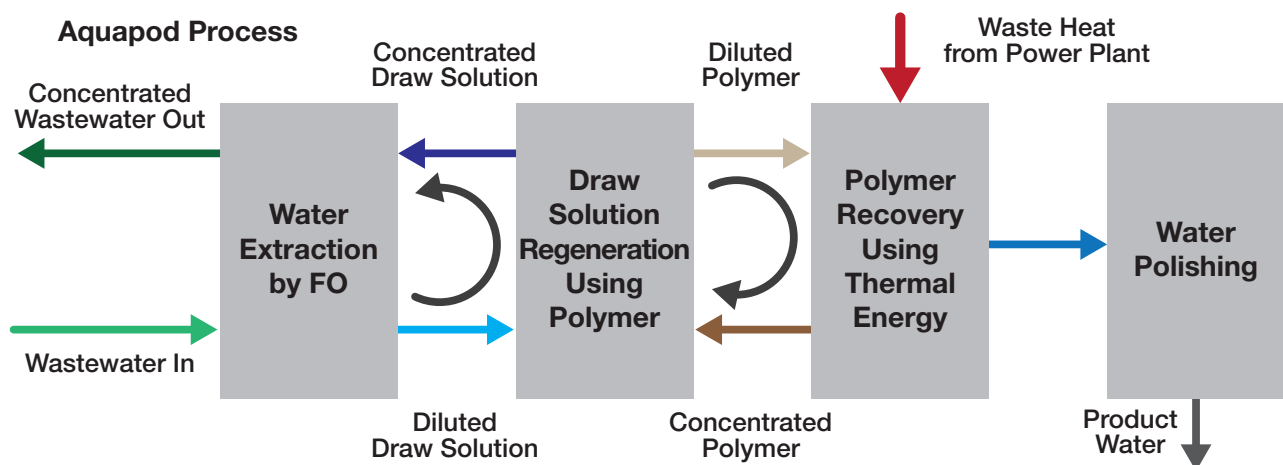

The process utilized by the University of Illinois.

Intensified Flue Gas Desulfurization Water Treatment for Reuse, Solidification, and Discharge

Performer	University of Kentucky Research Foundation
Award Number	FE0031555
Project Duration	01/22/2018 – 01/21/2020
Total Project Value	\$ 928,666
Collaborators	Southern Research Institute; Trimeric Corporation
Technology Area	Plant Optimization Technologies

This project will develop a process that is able to treat for reuse wastewater resulting from wet flue-gas desulfurization (FGD) scrubbing systems, leading to significant reductions in footprint and chemical consumption compared to the state-of-the-art water treatment technologies. To achieve this goal, the project will (1) evaluate the effectiveness of electrocoagulation with air-dissolved flotation in removing regulated species through design, construction, and testing of a one liter per hour sub-pilot unit, (2) examine a nanofiltration unit to achieve greater than 80 percent monovalent salt rejection, (3) conduct long-term operation of membrane-based filtration for FGD wastewater aimed at determining performance degradation, e.g., membrane fouling, (4) determine a practical salt concentration for

solidification resulting in an acceptable leachate, and (5) apply continuous capacitive deionization as a polishing step to remove any remaining government-regulated species below the effluent limitation guidelines requirements for recycling or discharge.

Wastewater treatment is one of the most important and challenging environmental issues associated with coal-based power generation. Compared to existing state-of-the-art biological treatment methods based on several physical/chemical steps, the proposed process will result in a reduction in the footprint of a physical/chemical treatment process and withdrawals of fresh water at power generation plants.

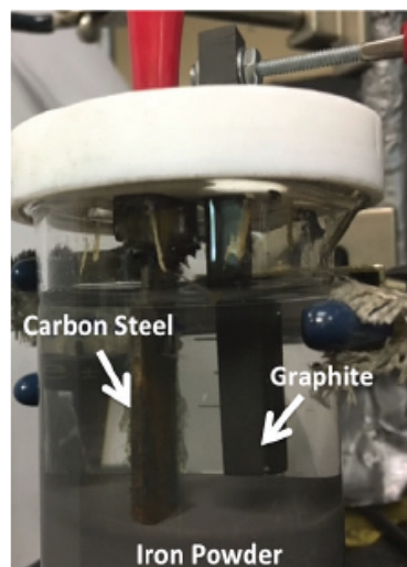

A lab-scale setup for electro-coagulation studies.

Dev. Cost-Effective Biological Removal Technology for Selenium & Nitrate from Flue Gas Desulfurization Wastewater from Existing Power Generating Facility

Performer	West Virginia State University
Award Number	FE0027893
Project Duration	10/01/2016 – 09/30/2020
Total Project Value	\$ 249,999
Technology Area	Plant Optimization Technologies

The overall goal of this project is to explore a variety of genomic, biochemical, genetic, and molecular approaches to understanding the molecular basis of selenium and nitrate sensing, uptake, and sequestration by algae and plants from flue gas desulfurization (FGD) wastewater. The ultimate objective of this project is to apply the knowledge gained to develop a cost-effective biological treatment to help reduce these compounds in FGD wastewater, reduce power plant use of freshwater, and increase biomass/crop production.

The work will focus on the following technical objectives: (1) investigate changes in transcripts and metabolism in algae

and plants in response to FGD wastewater and (2) explore biotechnological strategies to increase sequestration of selenium and nitrates in biomass for agricultural productivity.

The project will develop transcriptomic and metabolomic data for basic and applied water research relating to algae, duckweeds, and mutants/transgenic plants derived using *Arabidopsis* transfer-DNA (T-DNA). Anticipated project benefits include maximizing sequestration of selenium and nitrates in biomass for FGD wastewater remediation, reduction of power plant use of freshwater resources, and enhanced agricultural production.



Candidate genes in model system.

Produced Water and Waste Heat-Aided Blowdown Water Treatment: Using Chemical and Energy Synergisms for Value Creation

Performer	West Virginia University Research Corporation
Award Number	FE0031740
Project Duration	09/01/2019 – 08/31/2021
Total Project Value	\$ 400,000
Technology Area	University Training and Research

West Virginia University Research Corporation will develop and test an innovative treatment process that utilizes produced water (PW) to create chemical and energy synergisms in blowdown (BD) water treatment. The project goal is to maximize generation of a product stream low in fouling potential for reuse and a concentrated stream of commercial value (i.e., 10-lb brine) while reducing chemical and energy costs for the treatment. This treatment process consists of mature treatment technology and innovative use of mature technology (i.e., brine electrolysis) to enable step improvement in cost and energy requirements for BD water treatment over the baseline process. Specifically, the proposed treatment process consists of softening, organics and suspended solids removal, reverse osmosis, brine electrolysis, and thermal desalination. These treatment units are integrated to sequentially treat the PW and BD water from their raw water conditions to those of a product stream suitable for reuse and 10-lb brine as a saleable product.

Each treatment unit will be tested to quantify its treatment

efficiency and chemical and energy requirements. The treatment units will be integrated together into a single, packaged, prototype module that will also be tested using simulated or actual cooling tower blowdown water. In addition, the Recipient will develop a process model and conduct process simulations based on the experimental results and literature values to optimize the treatment process. The model will include a cooling tower and a condenser in addition to the PW-aided BD water treatment subsystem. A techno-economic analysis will be performed to quantify chemical and energy savings compared to the baseline as well as potential revenue generation.

If successfully implemented, this project will demonstrate a model process for closing unsustainable, open-ended waste streams generated in an industrial sector (i.e., gas production) by utilizing the waste streams in another sector (i.e., power generation) for value creation through technology innovation.

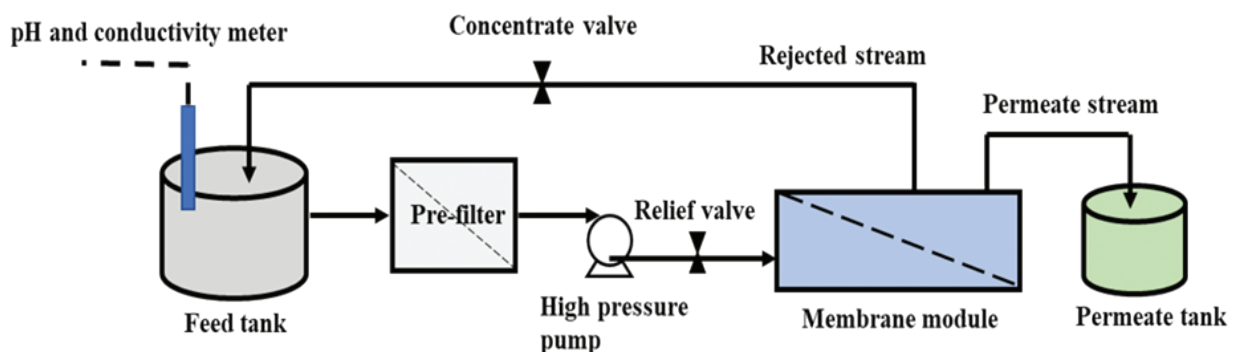

Schematic diagram of the RO treatment system.

ABBREVIATIONS

Al.....	aluminum	LOC.....	lab-on-a-chip
APCD	air pollution control device	MIT	Massachusetts Institute of Technology
As.....	arsenic	MF.....	microfiltration
ASV	anodic stripping voltammetry	MW	megawatts
BIAS	basic immobilized amine sorbent	NETL.....	National Energy Technology Laboratory
Cd	cadmium	Ni	nickel
CFPP	coal-fired power plant	NO _x	nitrogen oxides
ChemFET	chemical field effect transistor	OMI	Other Minority Institutions
CO ₂	carbon dioxide	Pb	lead
COTS	commercial off-the-shelf	PBI	polybenzimidazole
CPoC	critical pollutants of concern	pH.....	potential of hydrogen
Cu	copper	ppt	parts per trillion
DCSG.....	direct contact steam generation	R&D.....	research and development
ELGs	Effluent Limitations Guidelines and Standards for the Steam Electric Power Generating Point Source Category	RO.....	reverse osmosis
EPA	Environmental Protection Agency	SLIPS	superhydrophobic/slippery liquid infused porous surfaces
FE.....	Office of Fossil Energy	SO _x	sulfur oxides
FGD.....	flue gas desulfurization	T-DNA	transfer-deoxyribonucleic acid
FO	forward osmosis	TDS.....	total dissolved solids
GTI	Gas Technology Institute	TE	trace element
HBCU.....	Historically Black Colleges and Universities	U.S.	United States
HFM	hollow-fiber membrane	UCR	University Coal Research
HTE.....	heat transfer enhancement	USGS	United States Geological Survey
HTRI.....	Heat Transfer Research, Inc.	WPCD	water pollution control device
HUC	Hydraulic Unit Code	WRC	Water Research Center
LGE-KU	Louisville Gas & Electricity – Kentucky Utilities	ZLD	zero-liquid discharge

CONTACTS

Briggs White

*Technology Manager
Crosscutting Research*

412-386-7546

Briggs.White@netl.doe.gov

Patricia Rawls

*Supervisor
Enabling Technologies and Partnerships Team*

412-386-5882

Patricia.Rawls@netl.doe.gov

WEBSITES:

<https://netl.doe.gov/coal/water-management>

<https://netl.doe.gov/coal/crosscutting>

<https://energy.gov/fe/plant-optimization-technologies>

ACKNOWLEDGEMENTS

The Water Management Portfolio was developed with the support of many individuals. Key roles were played by Principal Investigators, Federal Project Managers, Technology Managers, Supervisors, and National Energy Technology Laboratory site-support contractors.



1450 Queen Avenue SW
Albany, OR 97321-2198
541-967-5892

3610 Collins Ferry Road
P.O. Box 880
Morgantown, WV 26507-0880
304-285-4764

626 Cochrans Mill Road
P.O. Box 10940
Pittsburgh, PA 15236-0940
412-386-4687

Program staff are also located in
Houston, TX and **Anchorage, AK.**

Visit us: www.NETL.DOE.gov

 [@NationalEnergyTechnologyLaboratory](https://www.facebook.com/NationalEnergyTechnologyLaboratory)

 [@NETL_DOE](https://twitter.com/NETL_DOE)

 [@NETL_DOE](https://www.instagram.com/NETL_DOE)



U.S. DEPARTMENT OF
ENERGY

August 2020