



**Pacific Northwest**  
NATIONAL LABORATORY

*Proudly Operated by **Battelle** Since 1965*

# Joining Technologies for Coal Power Applications

**Glenn Grant, Jens Darsell, David Catalini**

Pacific Northwest National Laboratory

**Fernando Rave**

Sandvik / Kanthal

**Bharat Jasthi**

South Dakota School of Mines and technology

**Vito Cedro**

Federal Program Manager, NETL

**DOE-FE**

**28<sup>th</sup> Annual Review Meeting**

**Fossil Energy Materials**

**Pittsburgh, PA**  
**May 19-23, 2014**

# Next Generation coal-fired power plants will employ advanced materials

- ▶ The next generation of gains in efficient fuel utilization will require a move to higher system pressures and temperatures.
- ▶ This will require new materials.
- ▶ Performance drivers for heavy section components :
  - ▶ **Good creep rupture performance (100,000hrs at 100MPa and 760C)**
  - ▶ **High elevated temperature strength and fatigue performance**
  - ▶ **Good corrosion/oxidation resistance, both fireside and steamside**

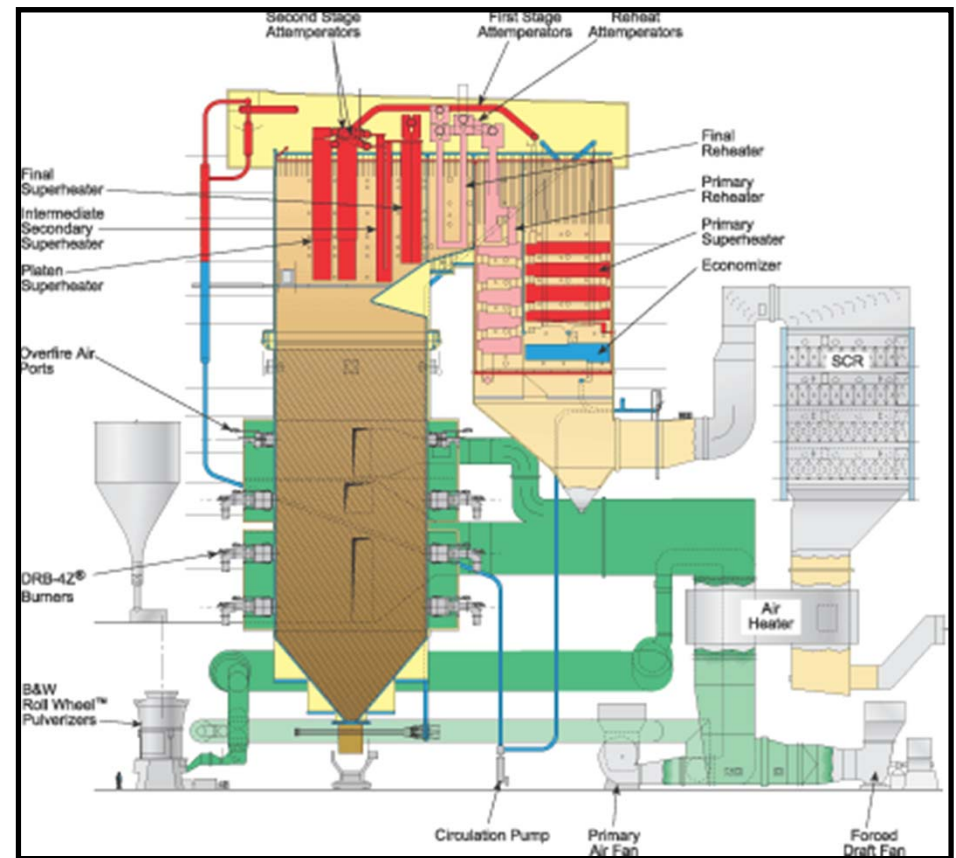

B&W SCR Boiler

Different parts of the plant have different targeted metrics. Ni alloys and ODS steels may be able to meet the 100MPa/760C target, (main steam, reheater pipe) but other parts may have lesser requirements (water walls, reheaters, superheaters) where austenitics or 9-12Cr ferritics can be used.

# The Challenge of New Materials

- ▶ Throughout the plant, higher performance materials of all classes have opportunities to improve fuel utilization, and thereby lower costs and reduce emissions (Ni alloys, Austenitics, Ferritics)
- ▶ Materials selection is driven by **cost - benefit calculation**
  - Cost of raw material
  - Cost of producing semi-finished product form (tube, plate)
  - Cost to fabricate
  - In the final analysis: total cost to implement the new material vs the fuel utilization cost savings from the efficiency gained.
- ▶ Often one of the **largest technical uncertainties** in the cost calculation is cost incurred when a material has a **shorter lifetime in service than originally thought**.
- ▶ One of the largest influences on the uncertainty of part lifetime is related to how the new material was bugged up when it was fabricated into the useful component , i.e. when it was:
  - Welded, formed, machined, drilled, or otherwise butchered from the great original state it was in when it left the mill

# What's the worse thing you can do to a high performance microstructure? Weld it.

- ▶ Fusion welding is usually very successful at producing a joint that can achieve or exceed parent metal strength at both room and elevated temperatures.
- ▶ The problem comes in long-term degradation performance (creep, fatigue, toughness, residual stress, and corrosion)

## Advanced Alloy Class

### ▶ NFA / Ferritic ODS Alloys

- MA 956
- Kanthal APMT

### ▶ Creep Enhanced Ferritics

- P91/P92

### ▶ Ni based Alloys

## Fusion Joining Issues

▶ Can't be fusion welded without segregation of dispersoid

▶ Weld nugget microstructure could be unfavorable for critical properties

▶ Heat input from joining creates unfavorable HAZ properties (Type IV Creep Failure)

▶ Melt-Solidification process may have issues with liquation cracking or create deleterious phases for creep or corrosion (possible TCP if high Mo), or can show low ductility and toughness

This leads to property knockdowns in design and higher costs in materials (esp Ni) when increased wall thickness allowances are driven by property knockdowns because of welds

# Joining Technologies for Coal Power Applications

## ❖ **Technology Development Objective:**

Develop alternate joining methods that can produce long-term performance in the joined assembly that is closer to the base metal performance

## ❖ **Approach**

Develop a solid-state, non-fusion joining method, Friction Stir Welding, and demonstrate the approach on three classes of advanced alloys:

- Nanostructured Ferritics (including Oxide Dispersion Strengthened steels - ODS alloys)
- Creep Enhanced Ferritics (including 9-Cr/1-Mo (Modified) steels)
- Precipitation Strengthened Nickel-based superalloy (Haynes 282)

# What is Friction Stir Joining ?

## Solid-state joining processes (no material melting)

- ▶ Spinning, non-consumable tool is plunged into the surface of a material.
- ▶ Friction and plastic work energy heats the material sufficiently to lower the flow stress.
- ▶ When material softens, the tool is then translated along the joint line causing material in front of the pin to be deformed around to the back, and forged into the gap behind the traveling pin
- ▶ The resulting joint is characterized by:
  - Fine-grained “nugget” composed of recrystallized grains (d)
  - Surrounded by a mechanically deformed region (c) and a heat affected zone (b)

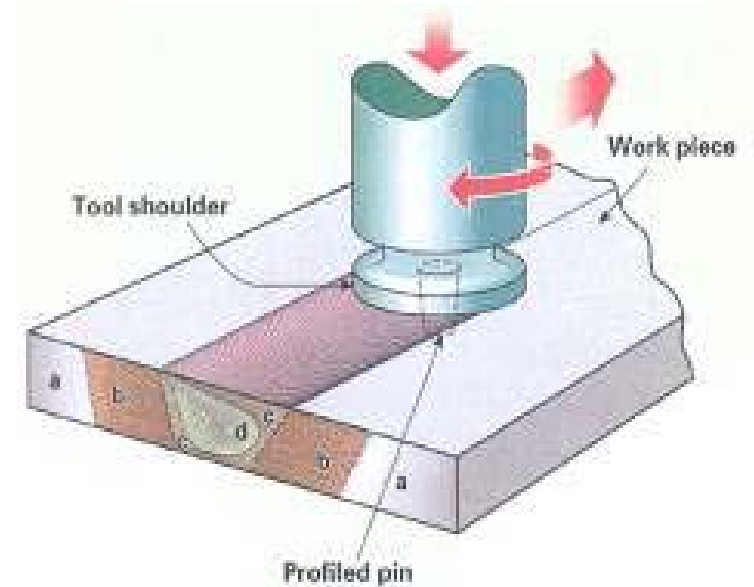

FSJ was invented and patented by TWI, Ltd. in 1991



Tools for Steels



# Friction Stir Joining Process Advantages

## Property Advantages

- Higher Toughness, Better Damage Tolerance
- Better Fatigue Performance
- Often Lower Total Heat Input:
  - Reduced HAZ degradation
  - Less sensitization in HAZ of Austenitic Alloys
- Lower Residual Stress and Distortion
- Fine grain nugget more amenable to NDE (x-ray, UT, etc.)
- Better results in Creep Rupture
- Better tolerance to gap, fit-up, and cleanliness
- High quality and repeatability (machine technology)

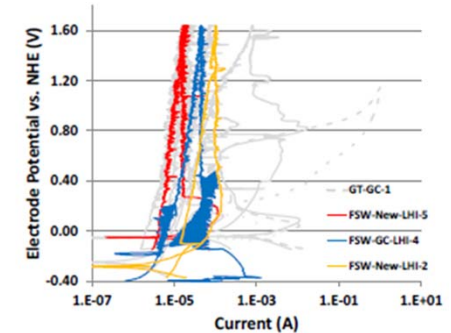
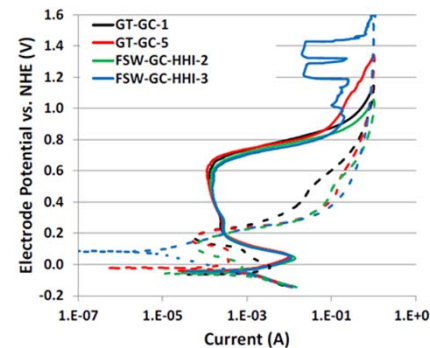

Cyclic Potentiodynamic Polarization (CPP) scans of GTAW welds in 304SS compared to FSW. GTAW shows potential for localized corrosion while FSW shows passivation behavior



Flat plate FS welds in HSLA65 plate, stay flat !

Weld Process	Dome Height (mm)	Concavity (Z/X ≤ 0.2)	Convexity (Z/X ≤ 0.1)	Mismatch (Y/X ≤ 0.1)	Undercut (Angle ≥ 90°)
Single Spot	11.7 ± 0.3	0.22 - 0.23	/	/	/
Twin Spot (across weld)	15.1 ± 0.4	/	/	0 - 0.21	116 - 180
Twin Spot (along weld)	14.3 ± 1.0	0.19 - 0.36	/	0.12 - 0.25	51 - 180
Laser-Plasma	11.9 ± 4.0	0 - 0.28	0.31 - 0.69	/	/
FSW	15.4 ± 0.5	/	/	/	/

# Friction Stir Joining Process Advantages

## Cost Advantages

- Single pass method – Faster on thick section welds
- No Consumables
- No Environmental Emission (Mn or hexavalent Chrome)
- No “Expert” Operators
- Lower recurring costs (but higher initial capital costs than GTAW/GMAW)
- Lower energy costs
- Reduced downstream costs (from residual stress and distortion management)
- Reduced costs in assembly end use (from longer part lifetime)



Terrestrial Linepipe Cost Sensitivity



Offshore Laybarge Cost Sensitivity

A. Kumar, D. P. Fairchild, M. L. Macia, T. D. Anderson  
ExxonMobil Upstream Research Co., Houston, TX, USA  
H. W. Jin, R. Ayer, N. Ma, A. Ozekcin, R. R. Mueller  
ExxonMobil Research and Engineering Company, Annandale, NJ, USA:



# Steel Friction Stir Welding – State of the Art

## Steel Thickness:

- Welds up to 10mm are possible using commercial tooling with rough process already established for some alloys
- Welds 10mm to 13mm are less common, tools are available commercially, but process parameters need to be established for most alloys
- Welds above 13 mm (0.5") have been demonstrated (up to 30mm), but very little knowledgebase on process robustness and tool durability

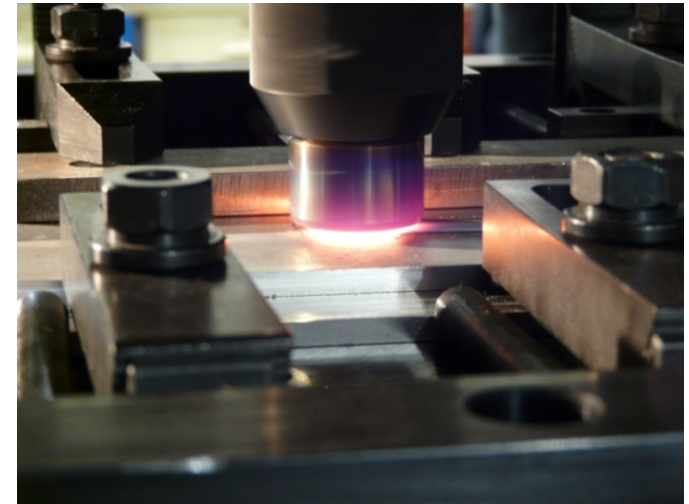

## Process Variables:

Weld travel speed: 75 mm/min (3 ipm) to 250 mm/min (10 ipm)

Tool rotation Speed: 90 rpm to 600 rpm

Tool load: 13 kN (2900lbf) to  
67 kN (15000lbf) for .75" thick welds

Process temperature: 700 C to 1100 C

## Tools:

PCBN Convex scrolled shoulder  
stepped spiral pin tool or,  
W-Re HfC smooth pin, small  
shoulder

Typical macrostructure of a fully  
consolidated, defect-free steel FSW weld



WRe Tool life: EWI recently showed  
88m in 19mm thick steel with a single tool

# High Temperature Materials that can be FSW

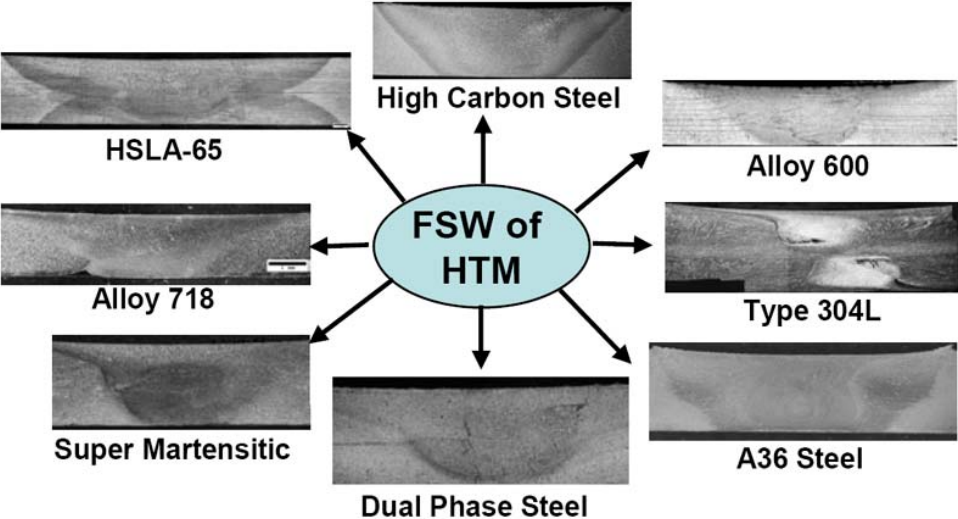
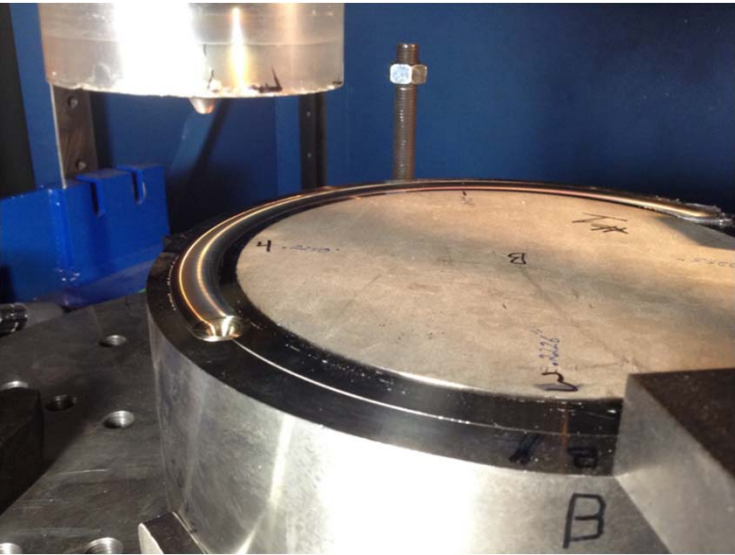
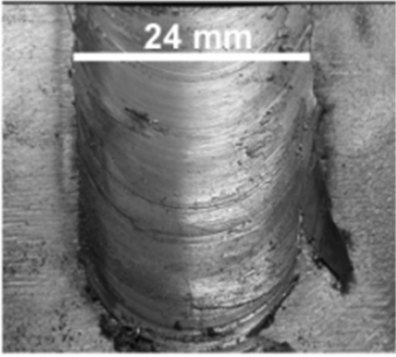
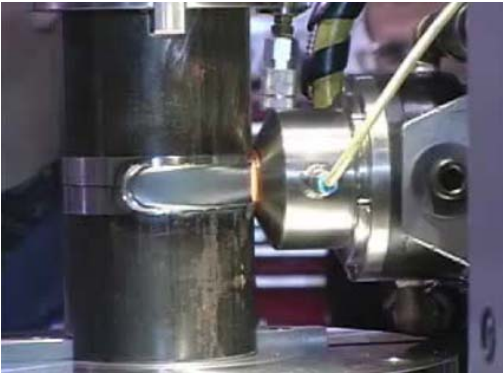

Photo courtesy Brigham Young University



Alloy 22 FSW showed only very fine intergranular TCP phases – no large grain boundary phases

**Production applications for steel FSW include pipe and tube manufacturing for the oil and gas industry (Global Tubing Inc.). TRL 7**

- ▶ Generalized Standards Efforts
  - FSW rules language has been added to the new 2013 ASME Section IX
  - AWS Subcommittee C6D – Best Practices Docs being written
  - ISO Standard
  - SAE D17.1(aluminum)
  - NASA (aluminum)
  - MNPDS Mil Spec
- ▶ Code Cases
  - 2 approved ASME Code cases running
- ▶ WPS PQR Environments
  - Qualification for Specific Applications or internal standards

FSW is poised for the TRL 4 to TRL 6 jump as a fabrication technology for power plant construction

# FSW of NFA / ODS

Kanthal APMT



# Friction Stir Welding of 20Cr-5Al-RE oxides Ferritic ODS (Kanthal APMT™)

- ▶ 20Cr 5Al Ferritic steel with good high temperature creep resistance and oxidation resistance similar to some Ni alloys
- ▶ Gas atomized (RSP) product with some rare earth additions, not an MA ODS alloy
- ▶ Alumina former to protect against corrosion and carburization

<u>Material</u>	<u>Fe</u>	<u>Cr</u>	<u>Al</u>	<u>Mo</u>	<u>RE</u>
APMT	bal.	22	5	3	Added

Oxid Met (2013) 79:29-39

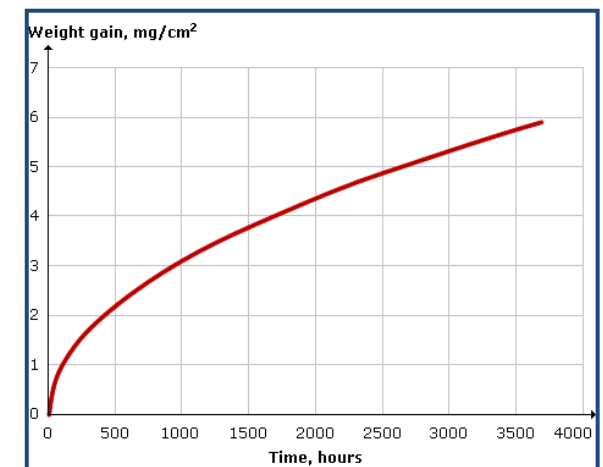
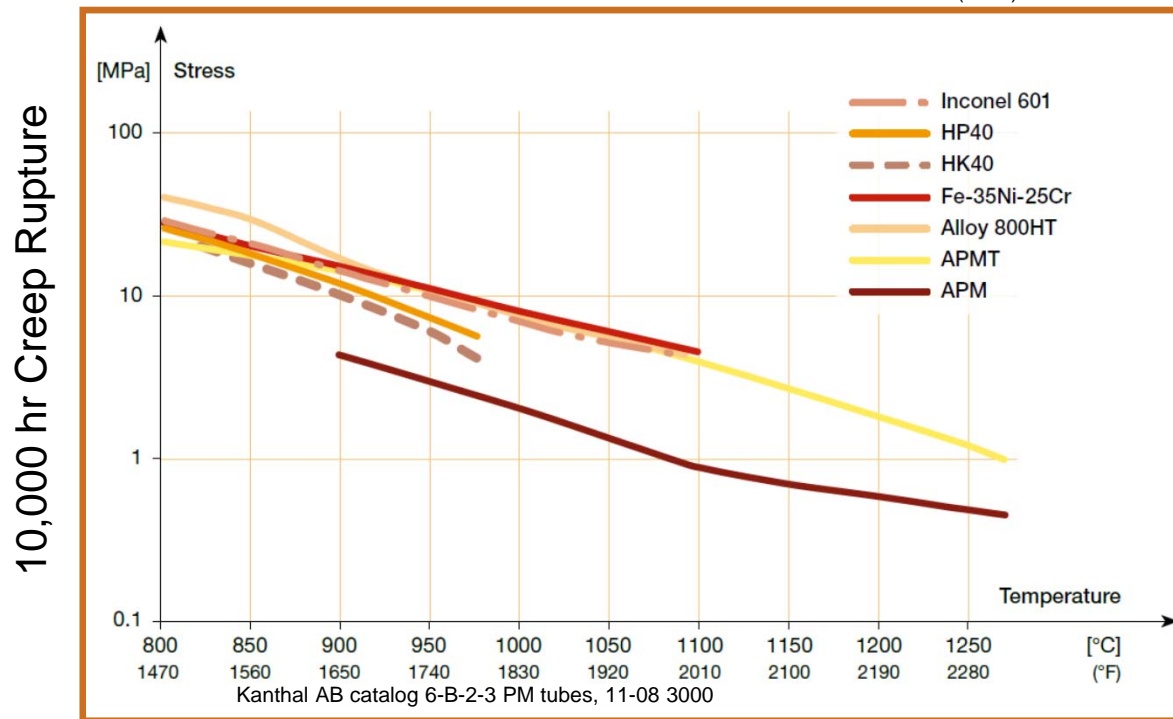

Designed for very high temperature applications in ethylene production tubing and heating elements

# Collaboration with Sandvik for Kanthal APMT

## ▶ Goals:

- To study effects of FSW on microstructure, strength, and creep in butt welds on APMT
- Develop methods to join APMT to an austenitic steel



## ▶ Contributions by Sandvik

- Kanthal APMT plates
- Friction stir tools
- Materials testing



# Typical microstructure of FSW APMT

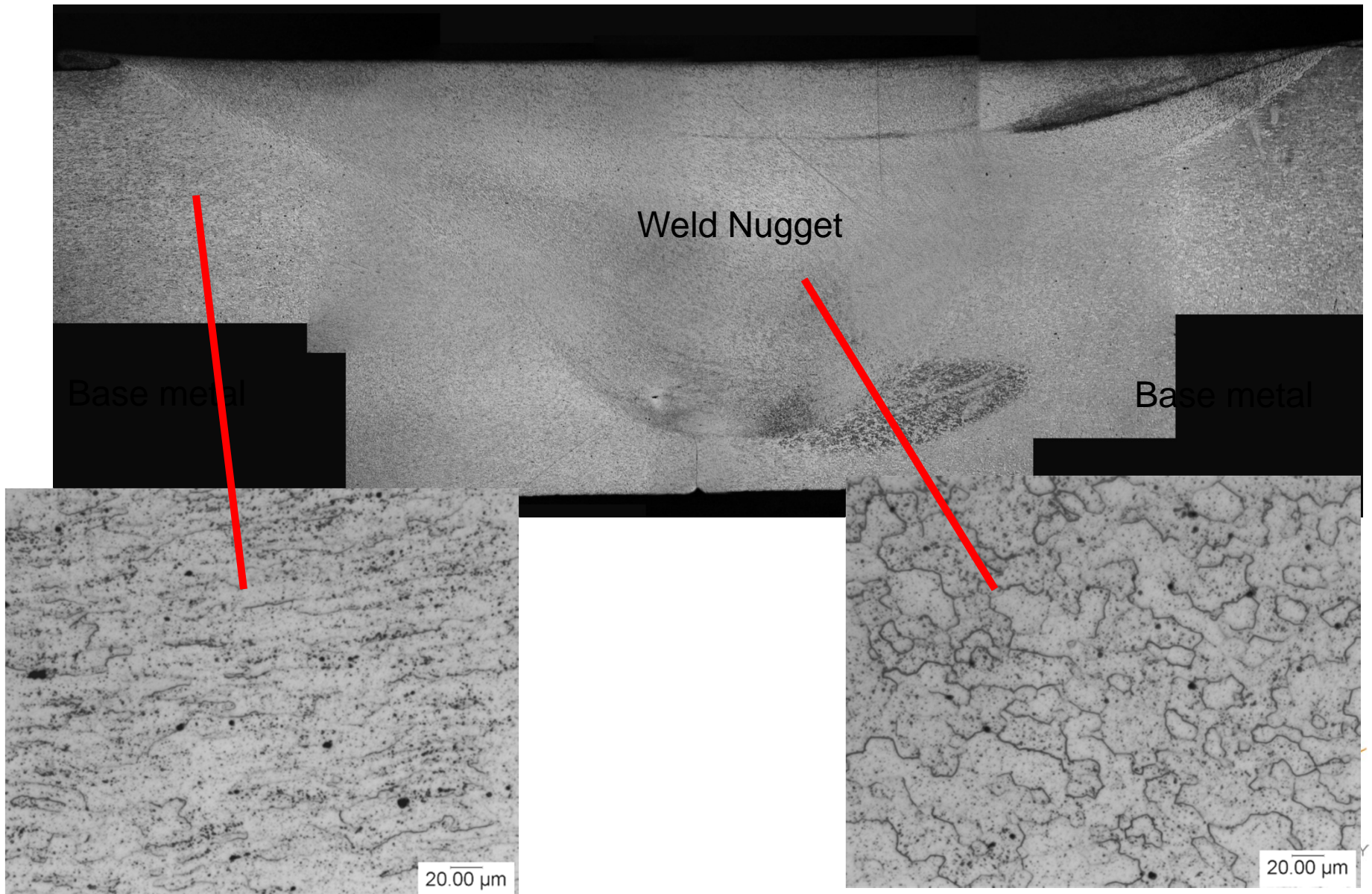

# Mechanical properties of FSW APMT

- ▶ RT Strength of FSW weld metal (only) is slightly improved over base metal, with a slight ductility drop

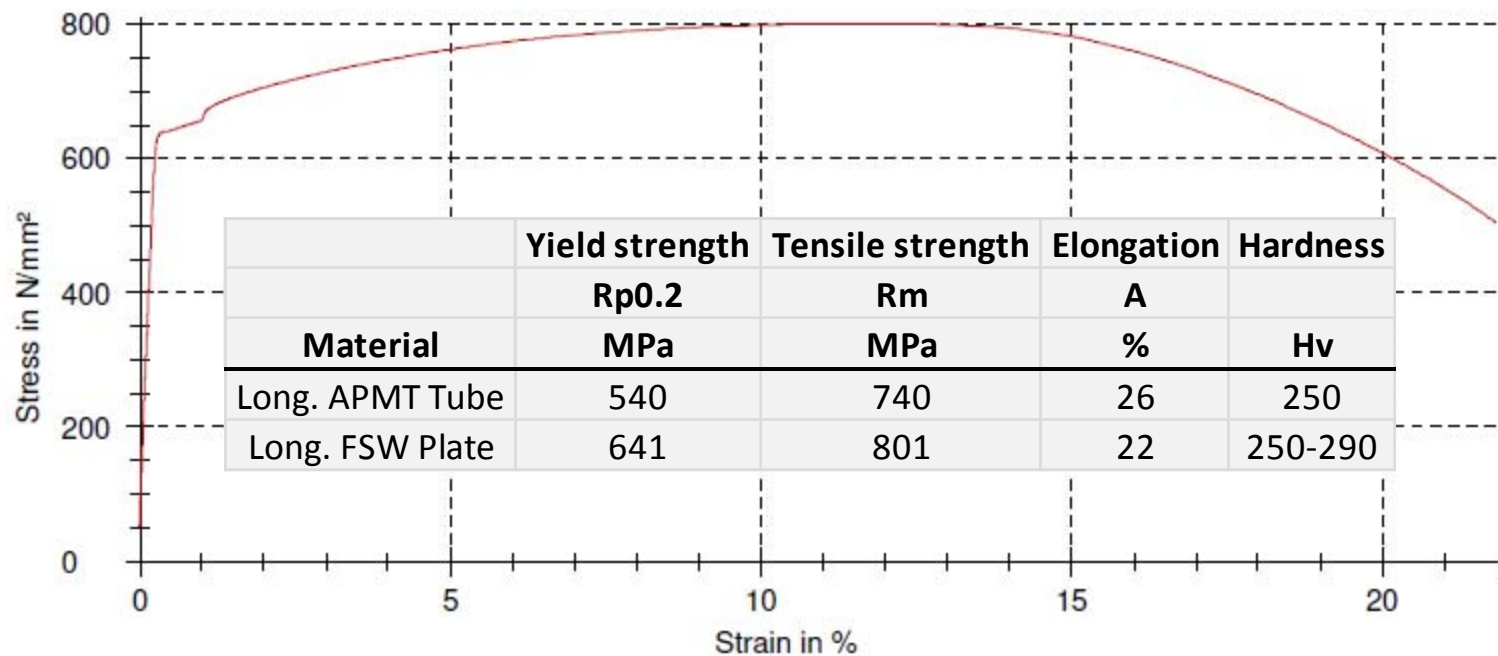

Weld metal is slightly overmatched at RT





# Creep Rupture Data

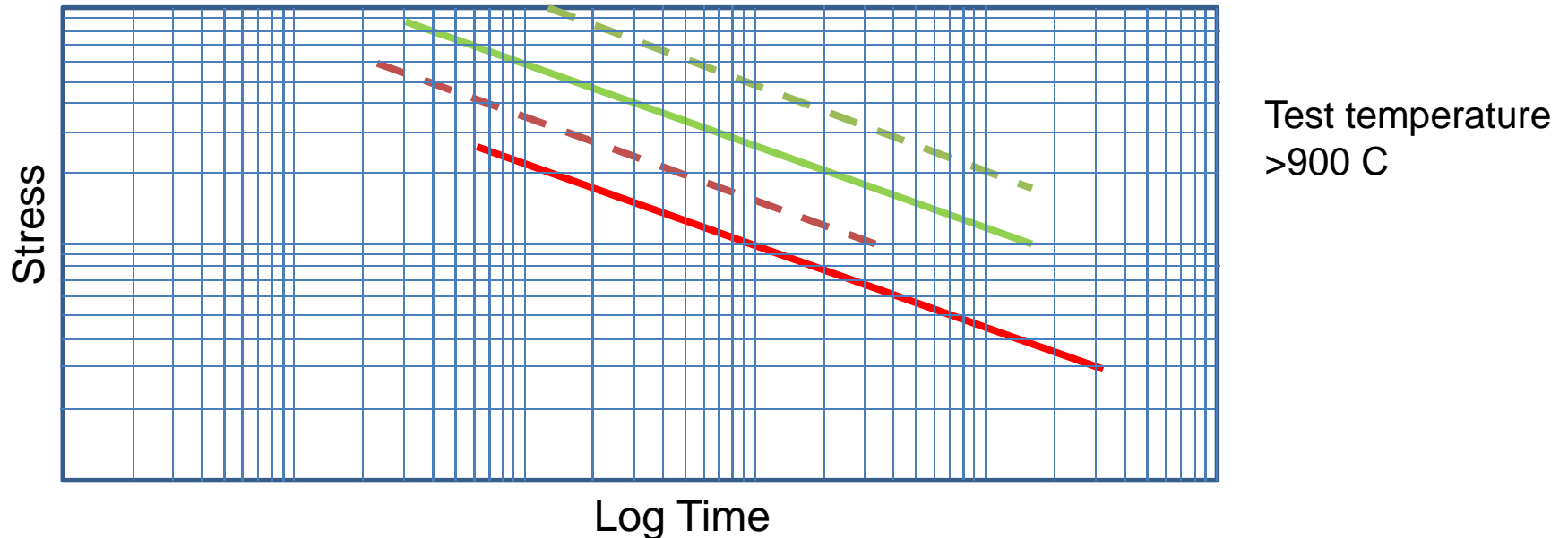

- ▶ Solid lines are fit to data from cross weld tension creep tests on GTAW butt welded tube. (All these tests ruptured in weld metal)
- ▶ Dotted lines are fit to data from creep tests on FSW weld metal specimens extracted longitudinally from FSW weld metal only
- ▶ Red curves are tests at a higher test temperature than green curves

FSW weld metal shows a ~3X improvement in creep life when compared to GTAW weld metal

# Nugget microstructure can be sensitive to weld process conditions

- ▶ If we subject the weldment to a PWHT (1100°C/1Hr) we can get different nugget microstructures depending on processing conditions
- ▶ FSW process temperatures ranges investigated
  - Cold: <850°C
  - Hot: >850°C
- ▶ We expect this to affect creep performance in this alloy in the same way it does in classically prepared MA ODS alloys – large grains are intentionally created by PWHT to enhance creep performance. Currently we have both microstructures in creep testing

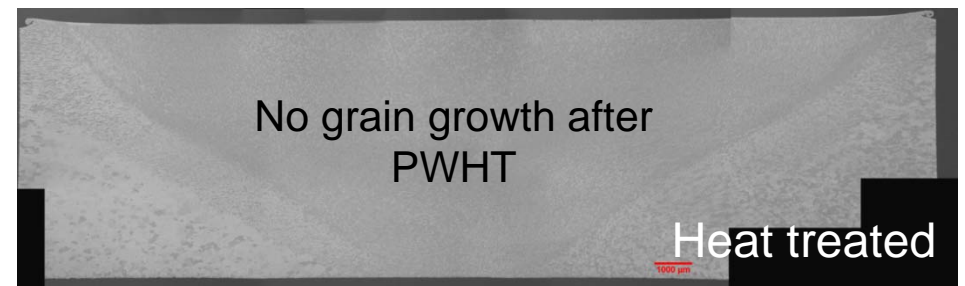
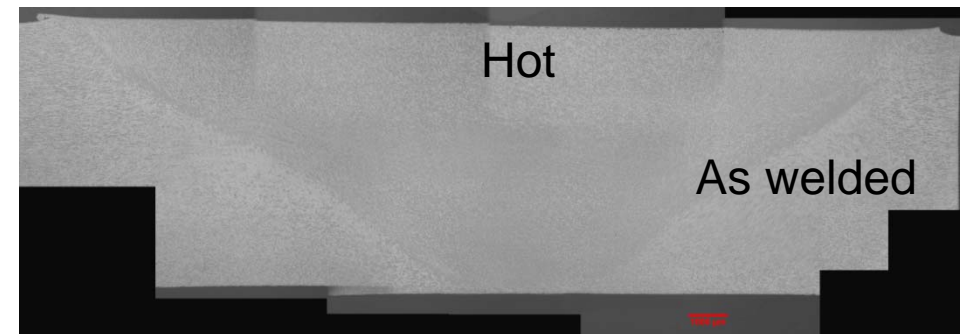
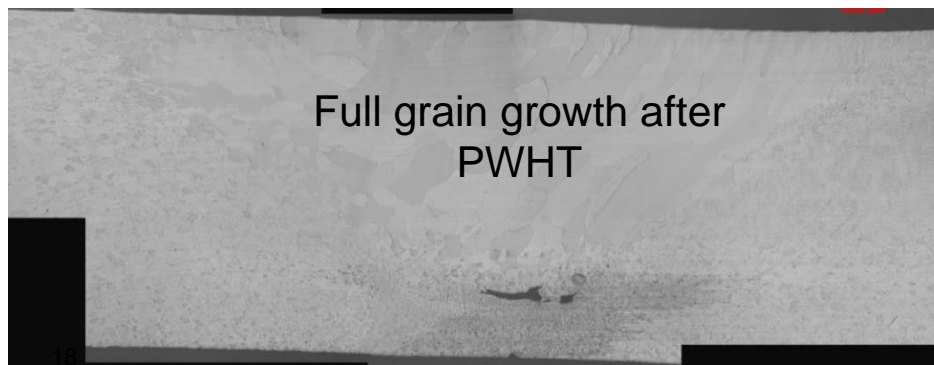
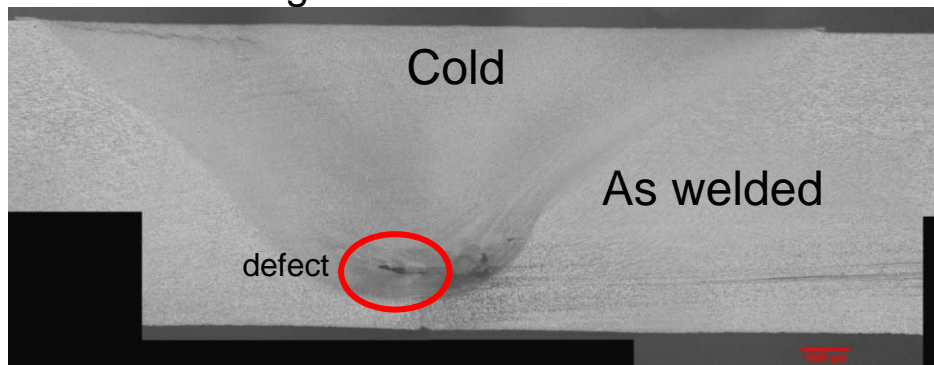

# Outline of Talk

- ▶ FSW Overview / Potential Process Advantages
- ▶ Case Studies
  - FSW of NFA/ODS
    - MA-956
    - Kanthal APMT
  - FSW of Haynes 282 (Gamma prime strengthened nickel alloy) brief update
  - FSW of P91 (Modified)

# Mechanical and Microstructural Evaluation of Friction Stir Processed Haynes® 282® Superalloy

- ▶ Dr. Christian Widener; AMP Center Director
- ▶ Dr. Michael West; REU Program Director
- ▶ Dr. Bharat Jasthi; Research Scientist-III, AMP Center
- ▶ Ian Markon; Undergraduate Researcher

# FSW of H282

- ▶ FSW welding trials were successful producing defect free welds
- W-Re 4%Hf-C convex tool
- Three-inch welds were made in forge control mode at 200 rpm with an initial plunge depth of 0.145"

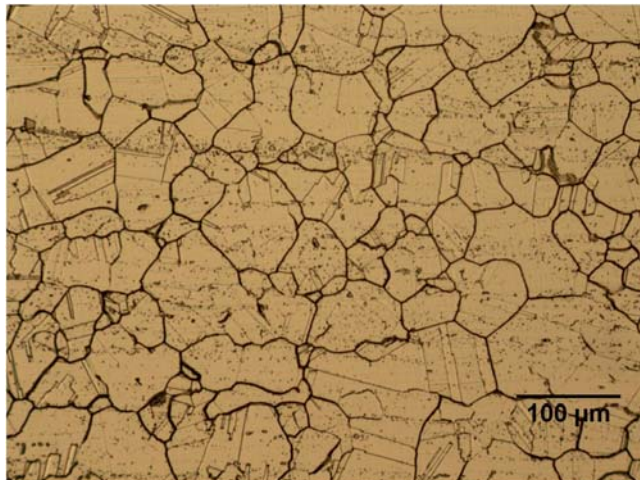
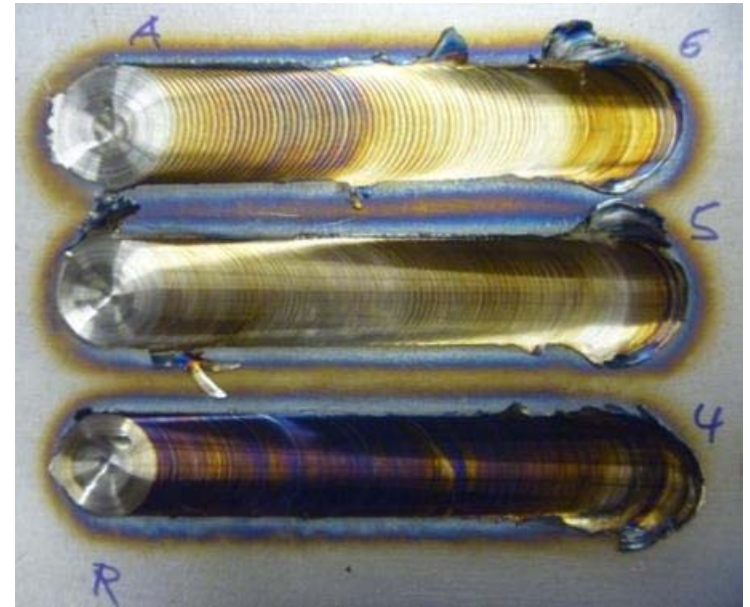

Microstructure of As-Received Haynes 282.

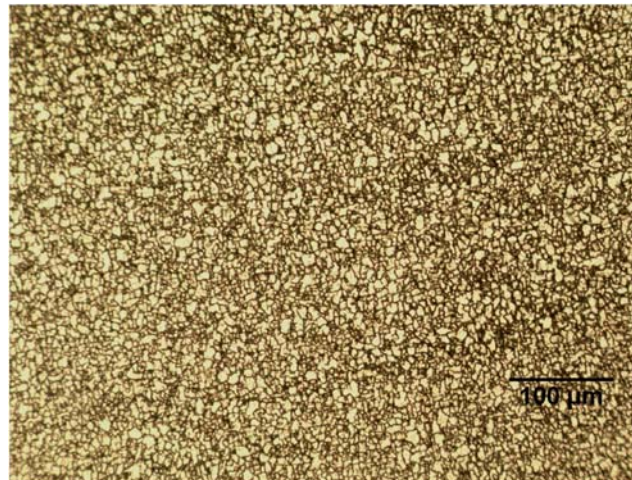

Weld 6 Nugget.

# Grain size analysis of Haynes 282 after HT

- ▶ No significant difference in grain size (average size  $\sim 59\mu\text{m}$ ) observed after standard two-step aging treatment for Haynes 282: 1850F ( $1010^\circ\text{C}$ )/2 hours/air cool + 1450 $^\circ\text{F}$  ( $788^\circ\text{C}$ )/8 hours/air cool

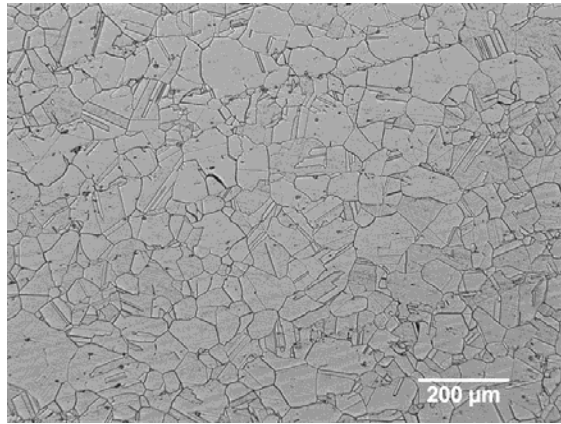

Parent

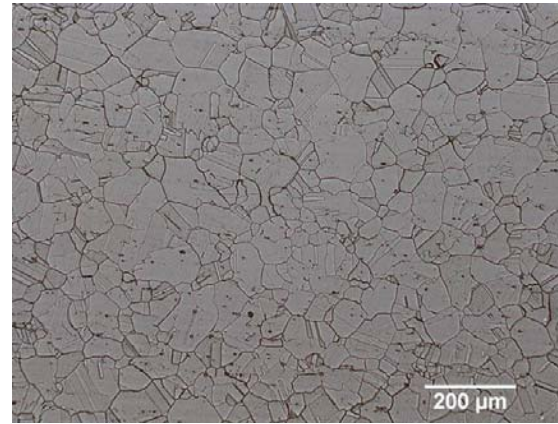

Parent + Aged

- ▶ Nugget regions also show no significant difference in grain size with thermal aging. The average grain size is  $\sim 5\mu\text{m}$

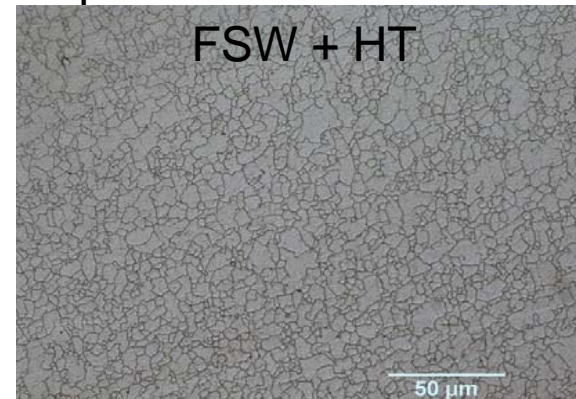
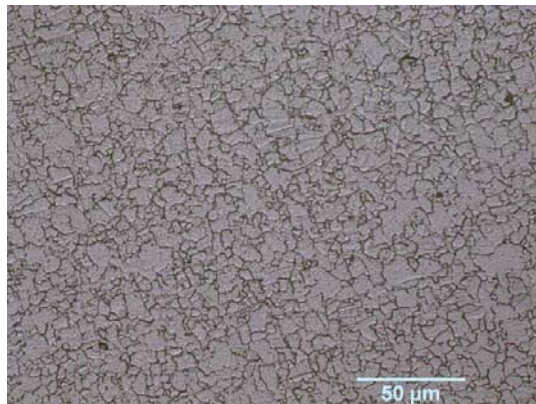

# Transverse Tensile Properties

- ▶ FSW (200RPM, 1IPM, 1° tilt, 7500lbs force) results in higher YS and UTS but reduces elongation in both aged and un-aged conditions as compared to parent Haynes 282

	Yield Strength (Ksi)	Ultimate Tensile Strength (Ksi)	% Elongation
Haynes 282 plate + Aged	103.7	166.4	30
Parent	60.7	117.1	64.9
Parent + Aged	89.2	158.0	34.5
FSW	65.6	123.2	29.3
FSW + Aged	101.6	163.4	13.1

*Haynes  
published  
values*

- Average of three samples per condition

# Initial Creep Rupture Data

- ▶ FSW weld metal plots on trend with H282 base metal
- ▶ All FSW weld metal has longer creep life than base metal at 760C / 345MPa
- ▶ FSW weld metal has slightly longer creep life than Fusion weld metal (despite very fine grain structure)

Red Squares are Base Metal data from Haynes

These data are projected points calculated from LM plots of base metal that has been SA then 2 step aged

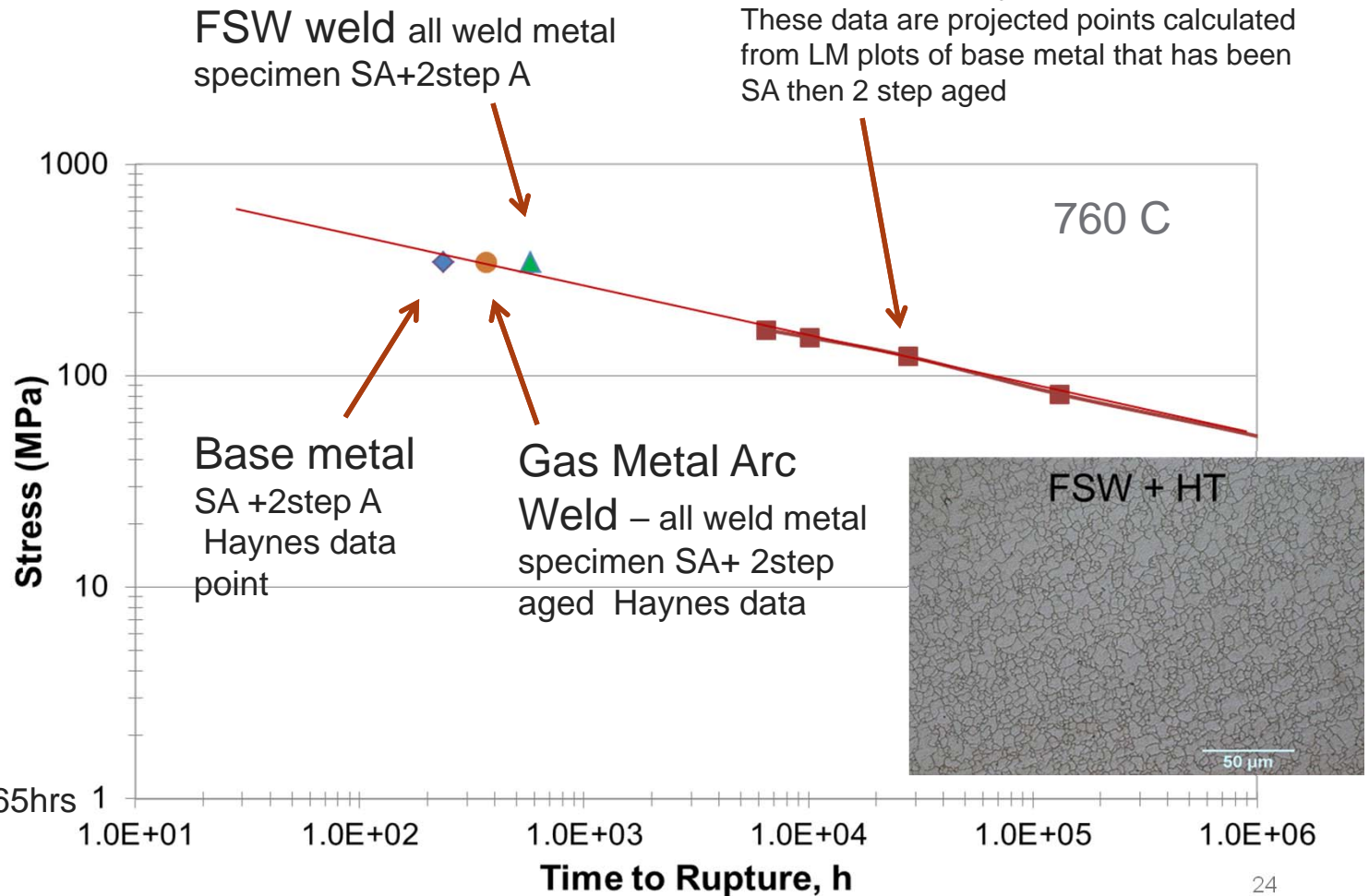

760C/345MPa:  
 FSW SA + A = 576hrs  
 H282 GMAW SA+A = 365hrs  
 H282 SA+A = 238hrs



# Outline of Talk

- ▶ FSW Overview / Potential Process Advantages
- ▶ Case Studies
  - FSW of NFA/ODS
    - Kanthal APMT
  - FSW of Haynes 282 (Gamma prime strengthened nickel alloy) brief update
  - FSW of P91 (Modified)

# Summary of progress FSW in P91 (Modified)

## Creep Enhanced Ferritic

# ASTM 387 Gr91 Class2 FSW Welds

- ▶ Gr91 is easily FSW welded
- ▶ Defect free welds in 10mm can be made at a wide range of process parameters
- ▶ Tool temperatures can be maintained during welding at any point from 780C to 980 C
- ▶ Travel speeds are comparable to SMAW but process is single pass
- ▶ The hardness in the nugget region is increased as compared to the base metal, but not as much as in fusion welded nugget material prior to PWHT

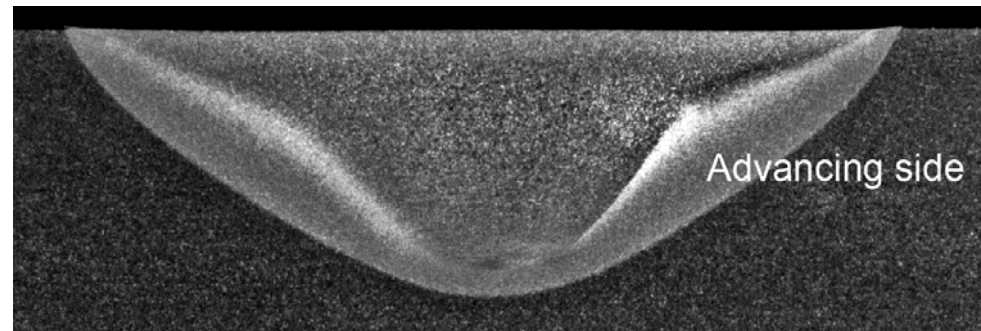

FSW in P91 (2011 03 09 0003 @ 3.5")

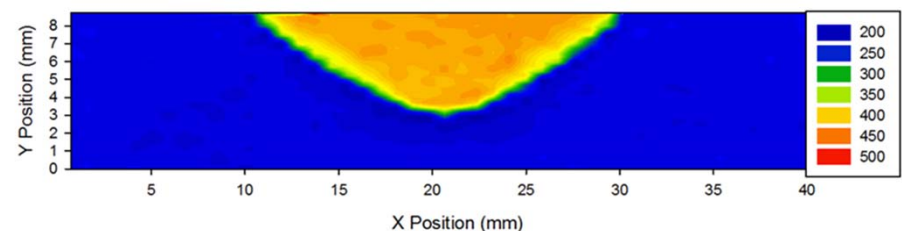

# Microstructure

- ▶ Packet and lath sizes are much smaller than fusion welding in both the nugget and the HAZ

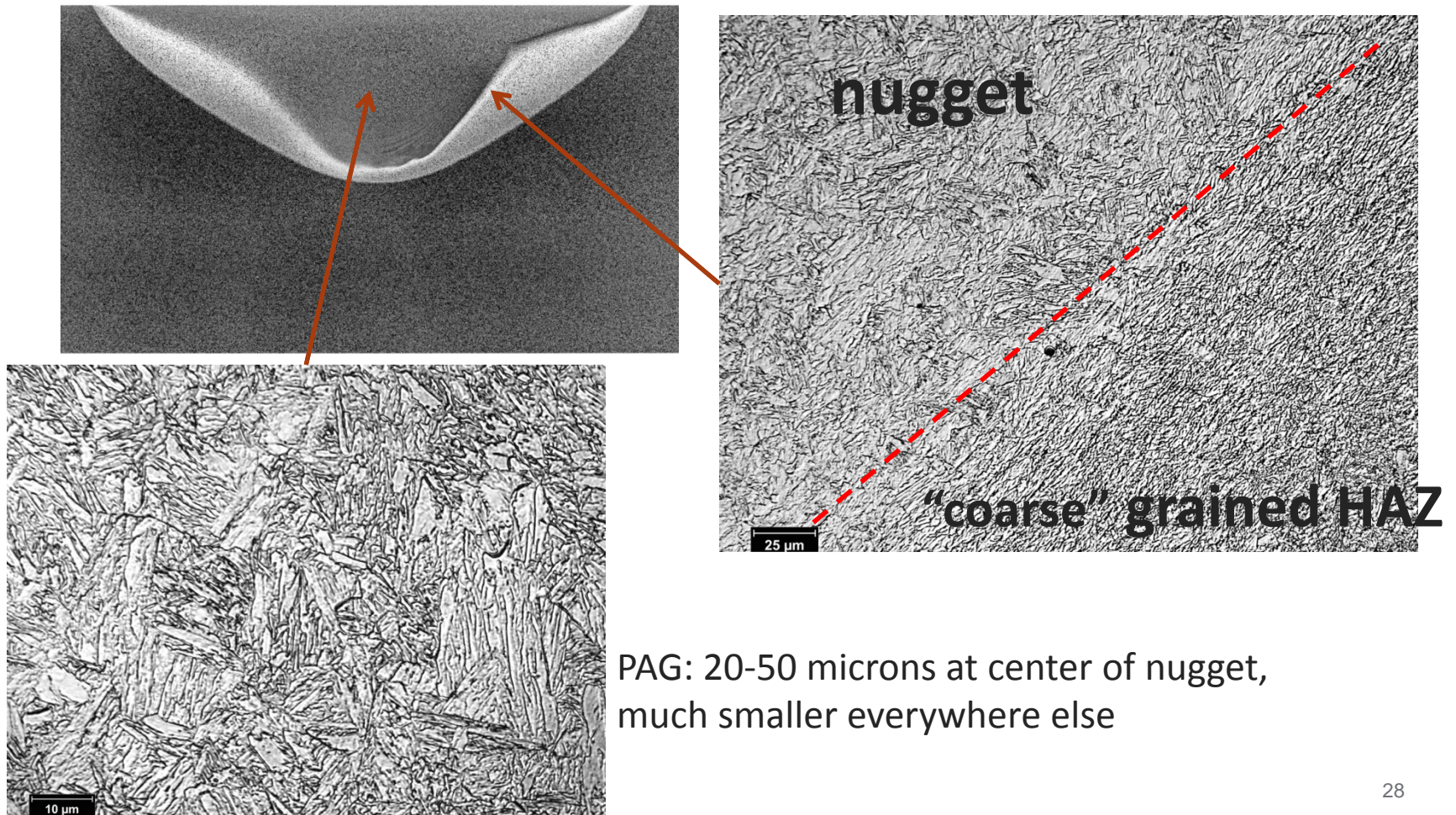

PAG: 20-50 microns at center of nugget,  
much smaller everywhere else

# FSW welds pass first level code requirements

## - Room Temperature Tensile

- ▶ Room Temperature tensile results show Cross Weld Tensile specimens **break in the parent** material (yield and ultimate comparable to base metal)
- ▶ Failure location of FSW P91 is in the parent away from the HAZ on the advancing side of weld

Base metal



FSW



Sample	Yield Stress, 0.2% (ksi)	Ultimate Tensile Stress (ksi)
ASTM standard for A387-G91, class 2 plate	60 min.	85-110
Base metal P91 - 1	72.1	95.1
Base metal P91 - 2	73.2	94.8
FSW P91 - 1	79.5	98.8
FSW P91 - 2	80.1	99.8
FSW P91 - 3	80.0	99.8

# Performance issues with welded CSEF steels

## Problem is not at room temperature

- ▶ Type IV Creep Failure.
- ▶ WSRF can be as low as 0.50 at long creep times (J. Parker, and others).
- ▶ This leads to greater allowances in pipe and tube wall thicknesses and/or reductions in operating temperature and/or pressure, with a reduction in plant efficiency.

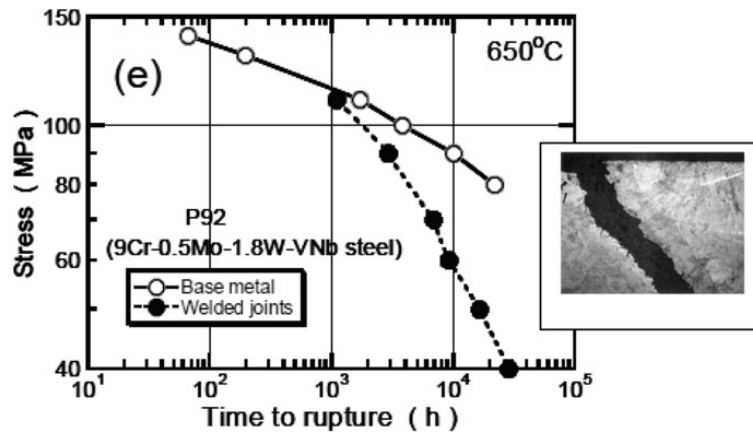

Parker J, International Journal of Pressure Vessels and Piping (2012), <http://dx.doi.org/10.1016/j.ijpvp.2012.11.004>

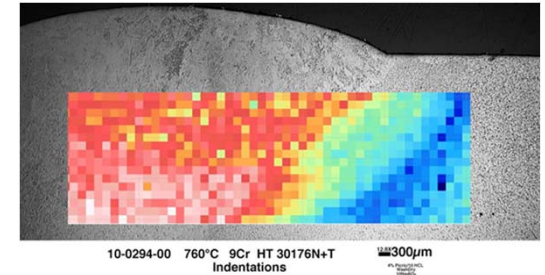

Slide from Mike Santella - ORNL  
04/19/2011

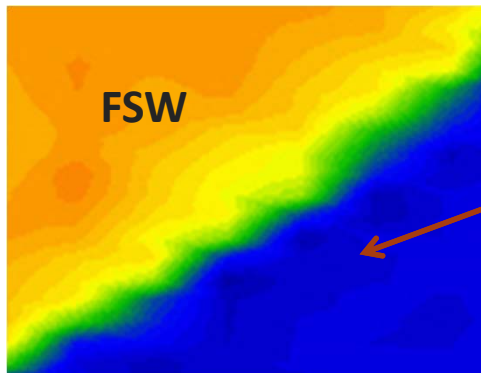
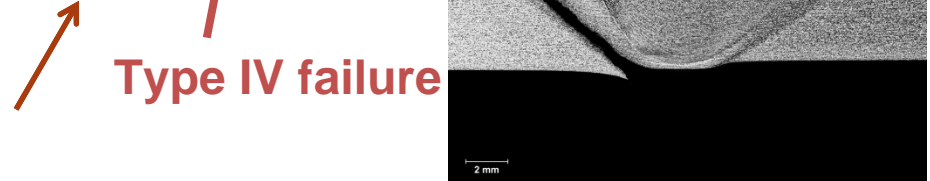
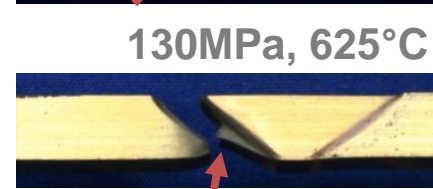

FSW also shows a low hardness zone

FSW also shows type IV cracking

# Why does Type IV develop?

## ► Creep “softness” in the fine grained HAZ (Type IV failure)

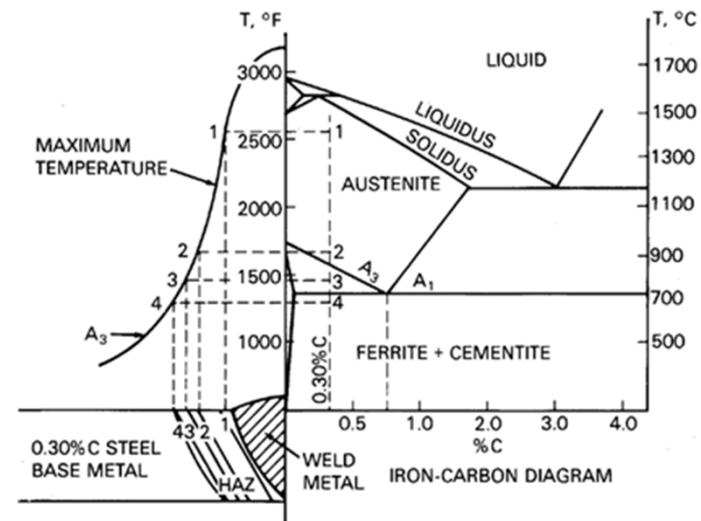
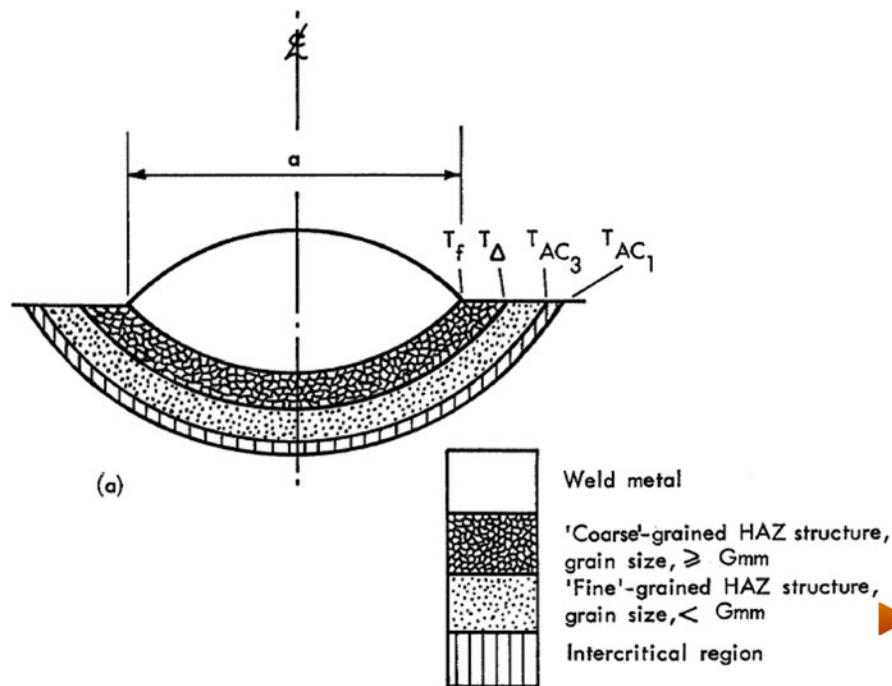

Parker J, International Journal of Pressure Vessels and Piping (2012),  
<http://dx.doi.org/10.1016/j.ijpvp.2012.11.004>

- CGHAZ: precipitate carbides dissolve – big PAG
- FGHAZ: not all precipitates dissolve- small PAG
- ICHAZ: precipitates still around - incomplete transformation to austenite on heating – untempered martinsite islands
- This is the problem area in creep

# Creep results Gr91 cross FSW Weld Specimens

- ▶ **FSW Gr91 shows much higher performance than fusion weld.**

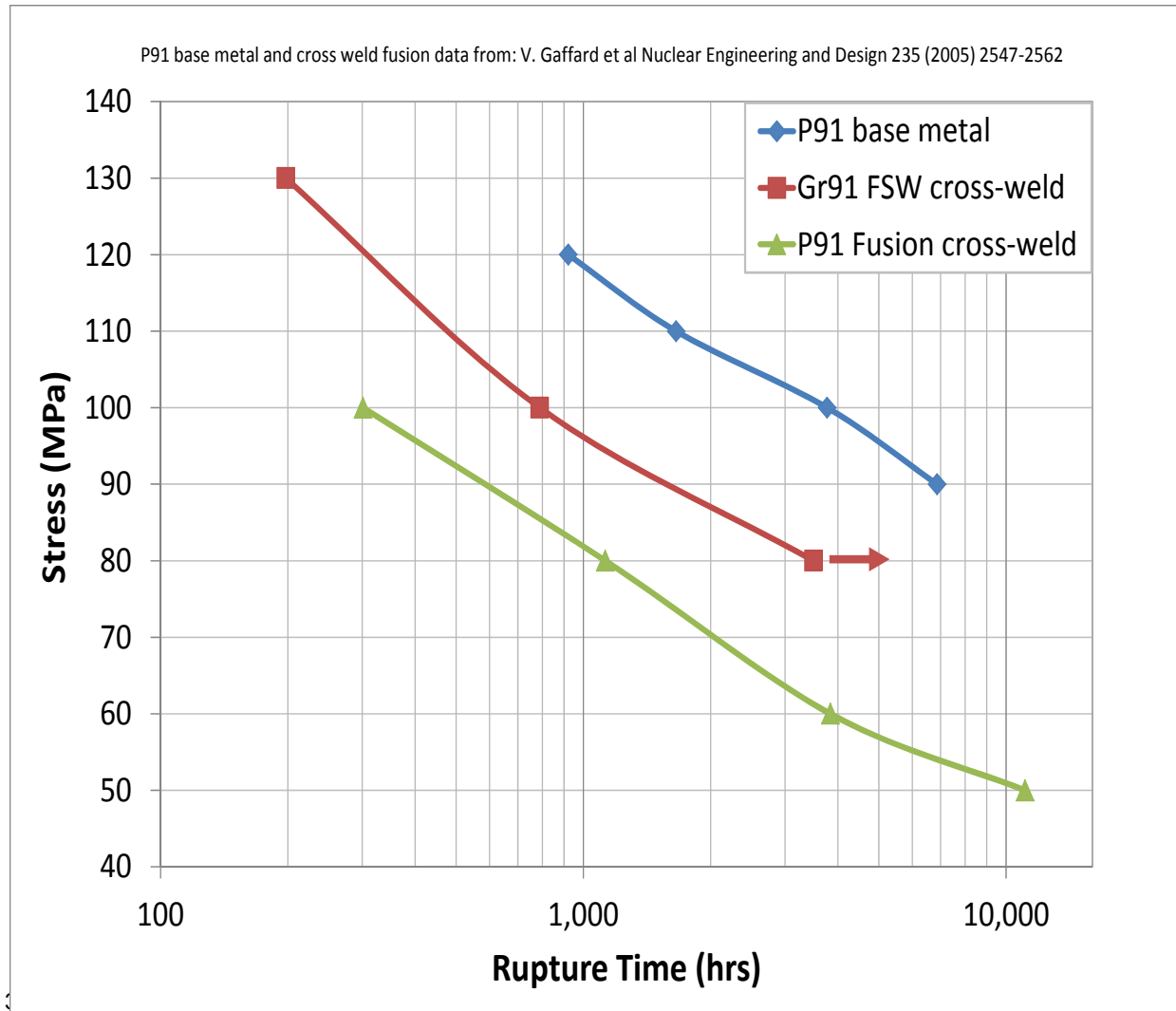

- ▶ **FSW cross-weld Gr91 shows ~3X longer in creep life than fusion cross-weld P91 (SMAW with PWHT)**
- ▶ **Design knockdown in strength is 32% for SMAW with PWHT (WSRF 0.68) vs. 18% for FSW (WSRF 0.82)**
- ▶ **FSW was not subjected to PWHT**



# Why does FSW have a better weld strength reduction factor?

- ▶ Lower peak temp and lower time at temp
- ▶ No well developed CGHAZ
  - does not seem to reach temperature much above AC3 so precipitates that keep austenite grains small are still around. This leads to poorly developed CGHAZ. Mostly FNHAZ
  - More gradual lath size variation across HAZ
  - More gradual property gradient across HAZ
- ▶ Narrow ICHAZ (geometric strengthening) from short time above  $a_c1$
- ▶ Lower residual stress  
(esp important where combined service loads or geometry affects stress levels)

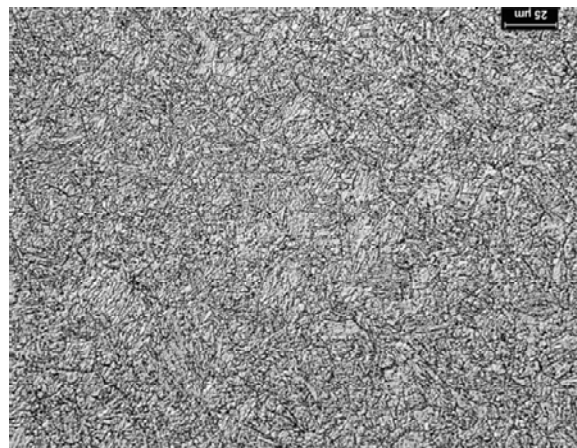
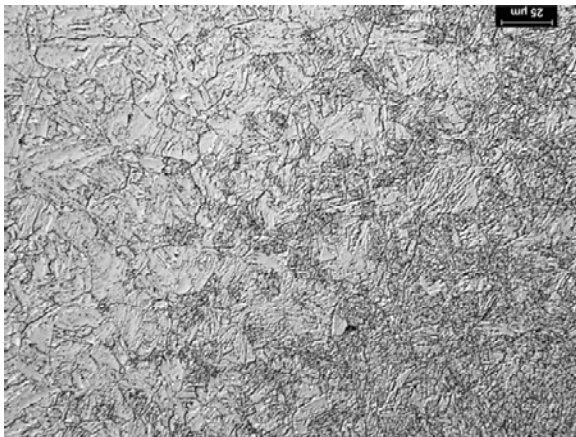
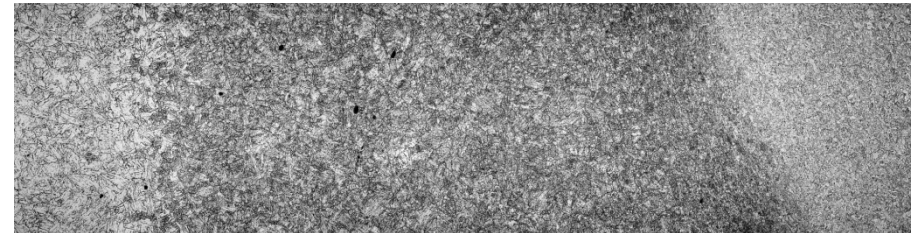

# Another possible advantage over fusion welds



Pacific Northwest  
NATIONAL LABORATORY

Proudly Operated by **Battelle** Since 1965

- ▶ Cooling rate and time in the intercritical region can lead to incomplete transformation to austenite with heating in the ICHAZ, which leads to untempered martensite islands upon cooling. The size of the islands is affected by time at temperature and cooling rate. When subjected to later creep conditions the boundaries of the large packets are nucleation sites for creep cavities

- ▶ FSW produces smaller prior austenite islands in the ICHAZ
- ▶ Less variation in lath size causes smaller stress concentrations, better resistance to cavitation



# Customizing heat input for improved properties

- ▶ Packet and Lath size is reduced with increasing travel speed and is an order of magnitude smaller than fusion weld nugget material

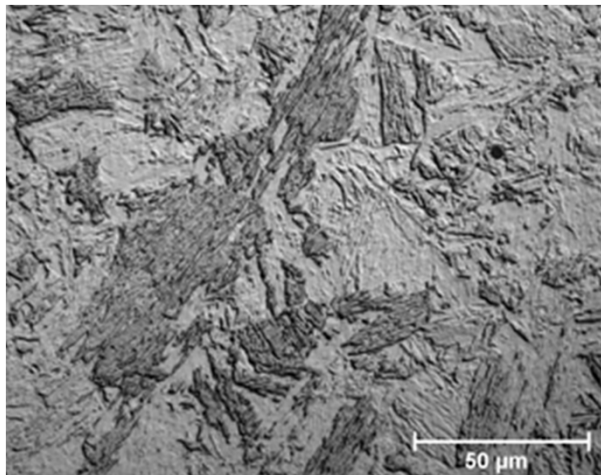

2ipm

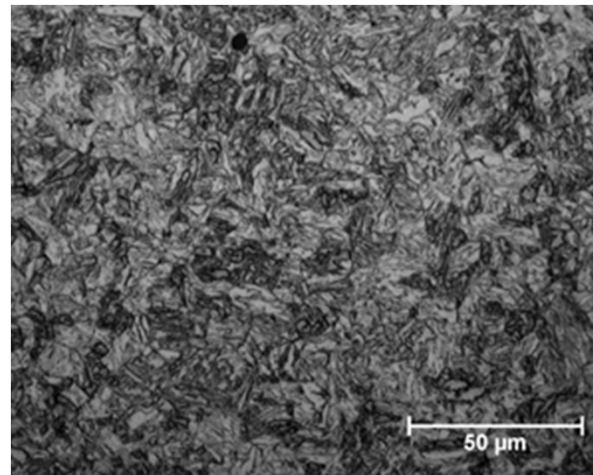

6ipm

- ▶ Packet and lath size can affect toughness
- ▶ And toughness can affect fatigue

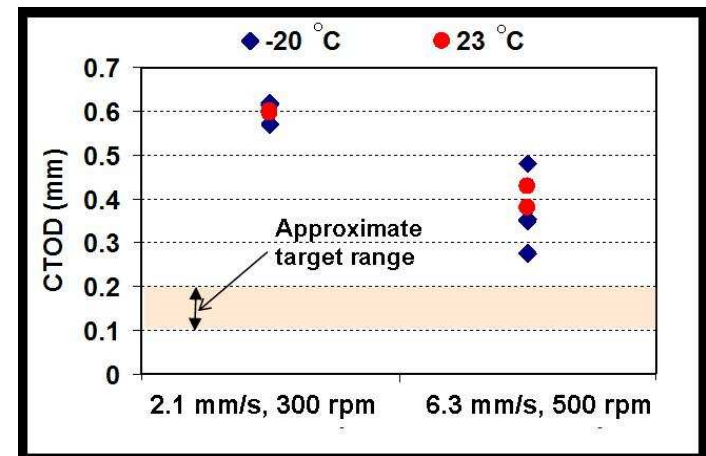

# Can this be improved further?

## There is an optimum place for each property metric

- ▶ In many material systems the FSW process window is large
- ▶ A large process window means a wide range of weld specific power levels can be used and still result in a defect free weld
- ▶ We have seen many cases where the best performance in strength is located at a different place in the process space from other properties (toughness, ductility, hardness, or creep performance)

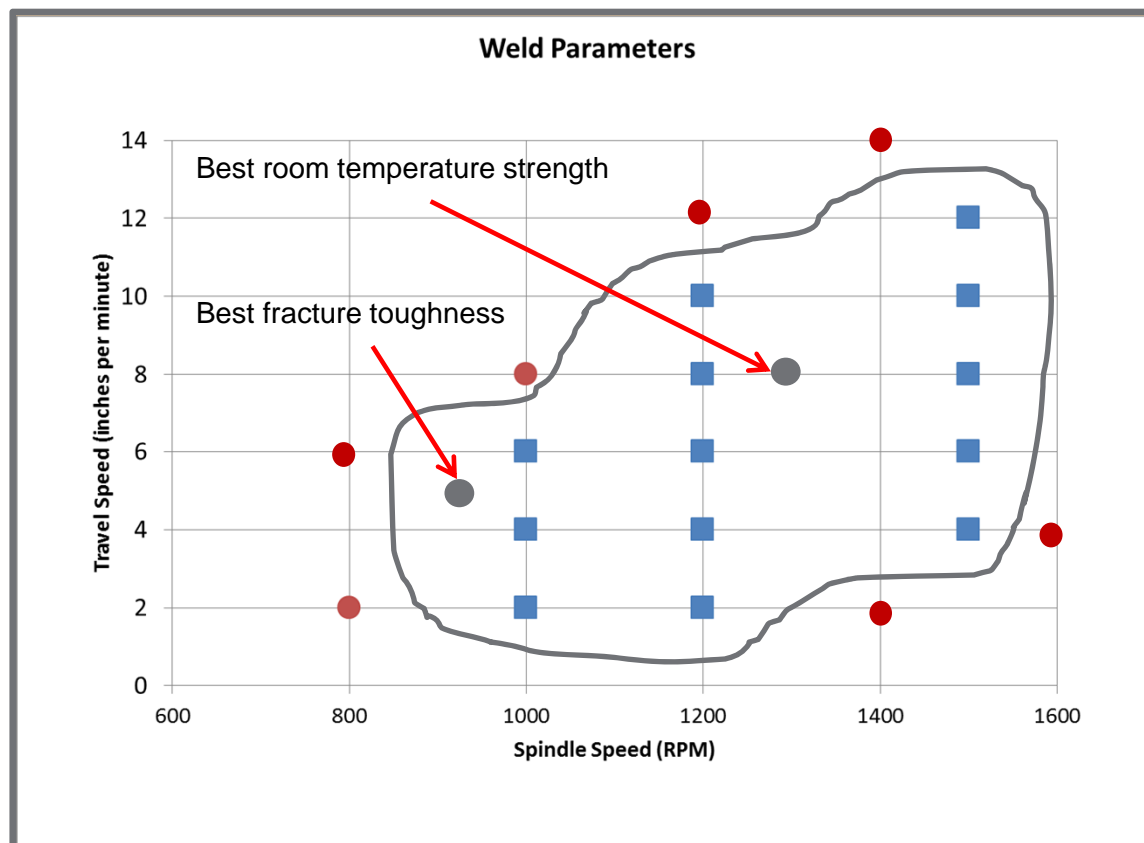

FSW allows you to process the material across a wide range of specific power leading to different strains, temperatures, and thermal histories

With that you can optimized microstructures for the required property

# Conclusions

- ▶ CSEF steels are Friction Stir weldable
- ▶ Creep performance is very good, both of the weld metal and in cross weld tension
- ▶ It is possible that WSRF can be raised by more than 10% and it is possible that FSW will allow for a reduced requirement for PWHT
- ▶ Fatigue and creep fatigue are also important failure modes at nozzle or header pipe/manifold intersections due to cycling thermal stresses and pressure pulses in the supercritical fluid at constrictions and sharp radii. FSW, due to the refined microstructures in the joint area, may also be able to show improved properties for fatigue and toughness in these regions as well.
- ▶ **FSW allows for enough knobs to be turned in the process to customized heat input. It may be possible to follow a path through thermo-mechanical space that will leave the weld region much closer to the parent microstructure than if it is fusion welded.**

# Conclusion - Next Steps

## ▶ **Kanthal APMT - New Project Partner Sandvik**

- Weld Metal performs on par with base material in creep
- Already use this material in tube form in ethylene production and heater tubes
- Currently APMT is a low cost, commercially available, ODS. The dispersoids and particles are not as fine as a typical NFA. But it may be “good enough” for some A-USC applications (not all components need 750/5000)
- FSW development for hot and cold processing conditions to determine effect on weld properties, grain growth, and creep strength
- FSW joining of APMT to austenitic is in progress
- Project close at end of FY

## ▶ **H282**

- Creep testing of FSW H282 weld metal at 760 C shows performance slightly better than base metal and GMAW weld metal
- Creep testing of cross weld specimens of FSW H282 in progress

## ▶ **Creep Enhanced Ferritics P91 (M) , Gr91**

- FSW cross weld tension specimens have 3 times the rupture life of fusion welded (+PWHT) specimens, without any PWHT of the FSW weld
- FSW weld metal has an order of magnitude better creep life than the base metal
- Current FSW parameters show good potential to reduce Type IV Failure
- Starting new project in FY14 on P91, P92, P122, and Co/N modified ferritics

**END**